

BMW Group Carbon Blaster

Operating Manual



Required Safety Equipment

Face Shield



Ear Protection



Gloves



Protective Clothing



The shop air supply should be dried using a general purpose filtering system; the tool is not recommended for use with a lubricating system.

Carbon Blaster Safety Devices

Main Air Supply Valve:



Off Position



On Position

Note: There is a pressure gauge on the tool; the maximum pressure inside this cylinder should never exceed 8 bar. A safety valve is installed in the lid which will automatically open at 8.5 bar.

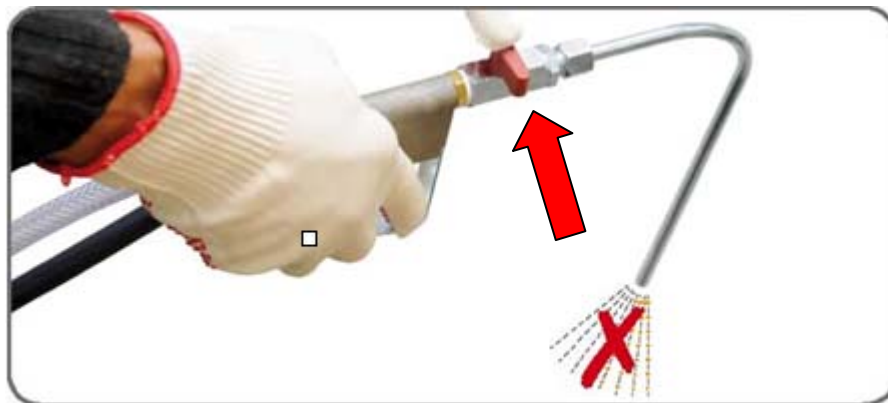

There is a two-way ball valve located on the handle; when the tool is not in use, always have this valve closed for safety. The illustration shows the valve in the closed position.

If any of the tool functions fail to operate properly, the device should be repaired immediately before further use.



The tool must be operated on a level surface. It is recommended that the tool be placed on the workshop floor while in operation.

Hoses and supply lines must be routed to the vehicle so that they cannot become trapped or tripped over while working.

Note: For the purpose of clarity, some of the instructions may show the cylinder head removed from the vehicle. Do not remove the cylinder head from the vehicle when performing carbon blasting.

Unpacking the Carbon Blaster:



1. Place the box on a level surface.
2. Open the box carefully and remove the carbon blaster.
3. Check for accessories:
 - Granule container with connected hose package and handle
 - Straight blasting wand
 - Angled blasting wand
 - 2 cylinder head vacuum adaptors
 - Operating manual – discard the manual included with the carbon blaster and only use the instructions attached to SI M 04 03 11.

Preparing the Carbon Blaster for Operation:



The carbon blaster is supplied from the manufacturer without a compressed air male coupling.

Remove the yellow transportation plug.



Install a male air coupling using $\frac{1}{4}$ " NPT pipe thread and gently hand-tighten.

To verify the tool is calibrated properly, the lid must be securely tightened and the cylinder should be empty.



Connect the shop air supply and turn on the air supply valve.

The shop air supply must be oil-free and dry. It is recommended that a suitable inline shop air water separator be used.

The water separator is not included.





The pressure reading on the gauge should be 8 bar.

Once the proper operating pressure has been verified, disconnect the shop air supply and allow the canister to depressurize before opening.

Filling the Carbon Blaster with Blasting Material:



The shop air supply must be disconnected and the air supply valve placed in the off position.



After disconnection, the pressure gauge must read zero pressure.



Loosen all three eye bolts.



Remove the cylinder lid.

Caution: The cylinder lid has a fitted o-ring; avoid damaging or misplacing.



Pour the blasting material into the container.

Blasting Material Specification:

20/30 or 0.45-0.80mm walnut shells

Never reuse blasting material. Reusing blasting material will cause clogging of the control valve.

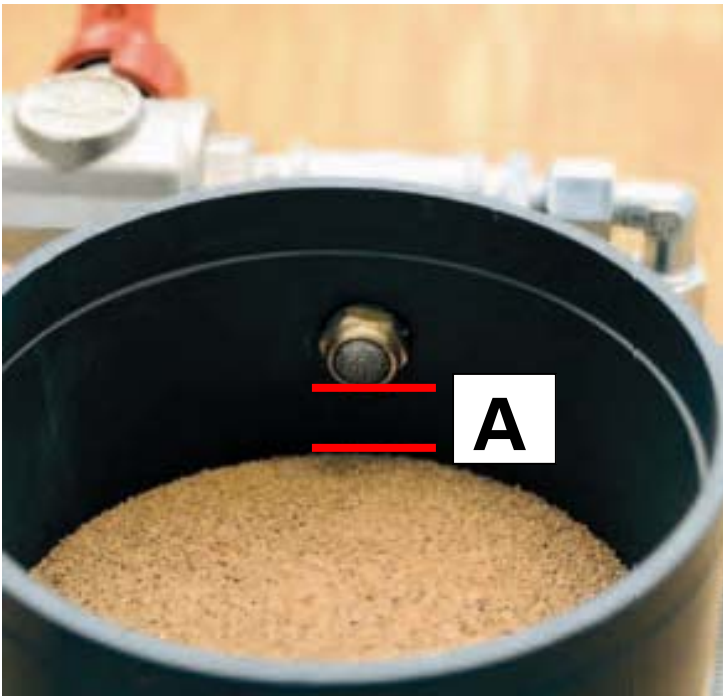

Do not overfill the cylinder!

Fill the cylinder until the material is approximately 30mm below the air inlet port on the side of the cylinder.

A = 30mm



Verify the condition of the lid's o-ring seal.

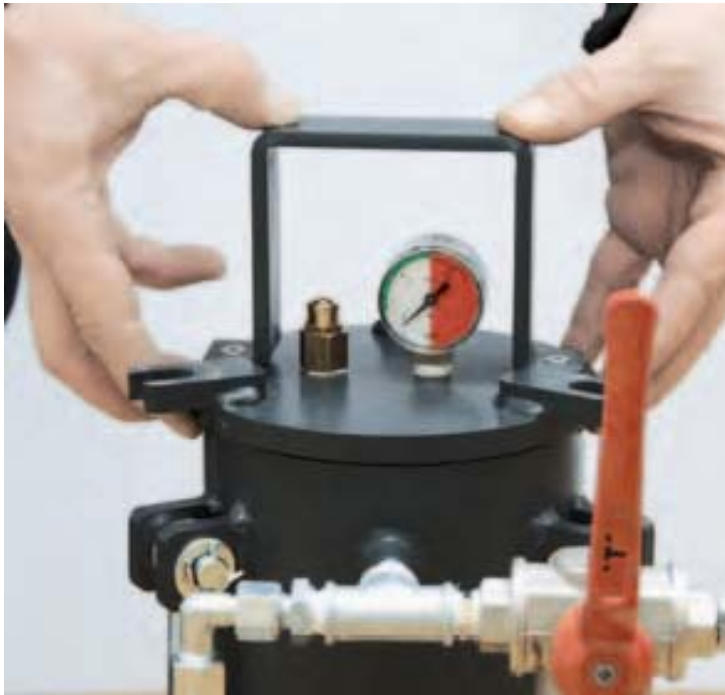

Place the lid on the container.

Hand-tighten all three eye bolts.



When not in use, always move the air supply valve to the off position. The off position is shown.



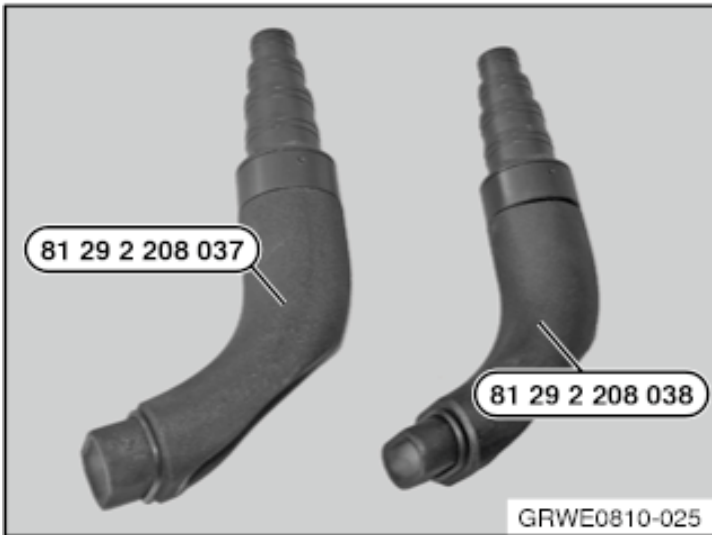

Select the appropriate cylinder head vacuum adaptor.

P/N 81 29 2 208 **038** = MINI N14 Engine

P/N 81 29 2 208 037 = Future use

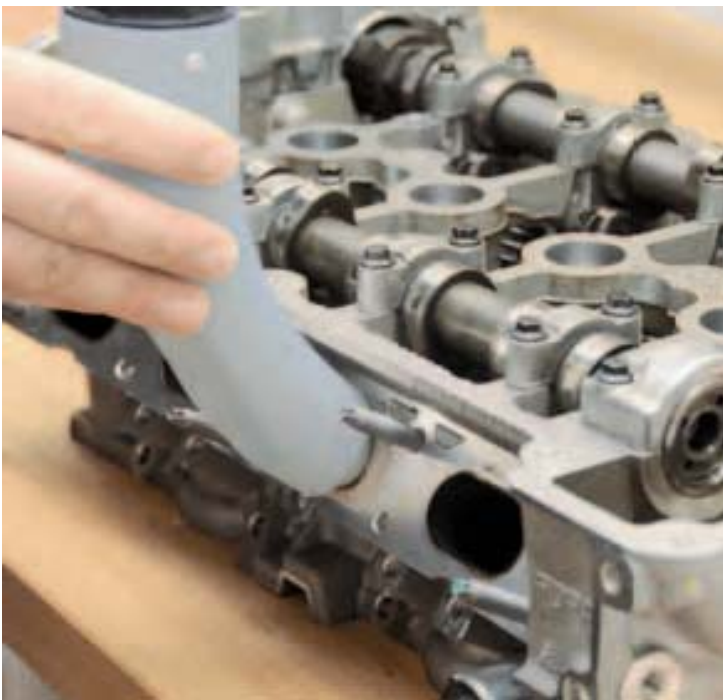

Insert the adaptor into the cylinder head intake port. Blasting material will escape and cause an unsafe situation if the wrong vacuum adaptor is used.

Cover all the intake ports that are not being cleaned with 2" wide tape to avoid loose material from falling into the engine.

Note: For the purpose of clarity, some instructions may show the cylinder head removed from the vehicle. Do not remove the cylinder head from the vehicle.



Connect the vacuum hose and secure with a hose clamp.

The hose clamp, vacuum and hose are not included.

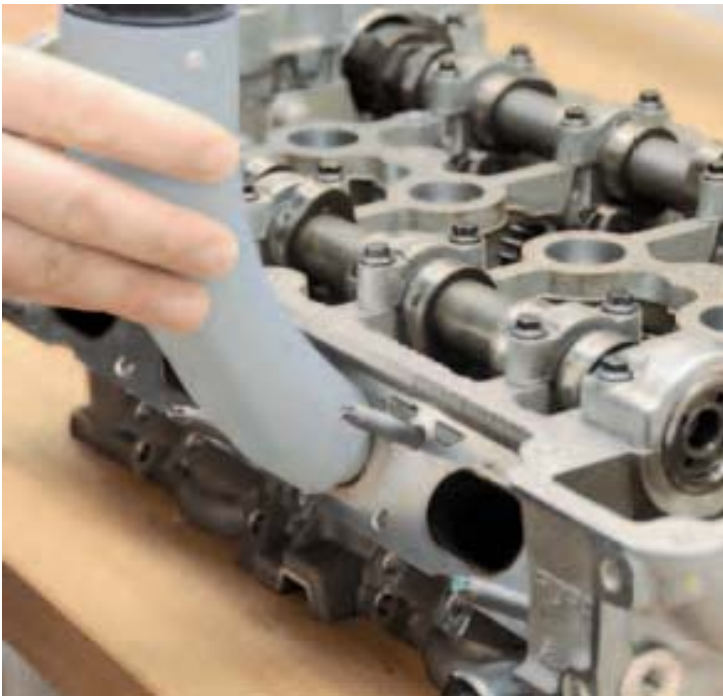

Insert the cylinder head vacuum adaptor in the intake port with the vacuum hose connected. Verify that all connections are secure and leak-free with the vacuum turned on.

In order to use the carbon blaster to its full operating potential, the vacuum cleaner filter element should be cleaned or replaced with regularity.

Note: For the purpose of clarity, some instructions may show the cylinder head removed from the vehicle. Do not remove the cylinder head from the vehicle.

Attaching the Blasting Wand to the Carbon Blaster:

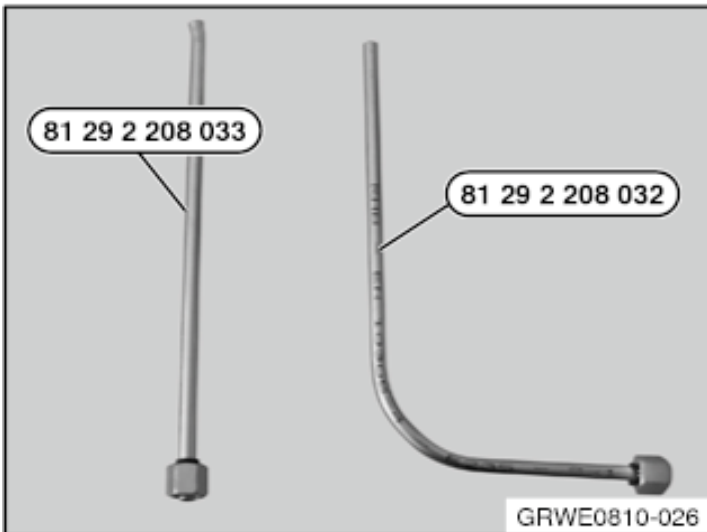

Select the appropriate blasting wand for the engine variant.

P/N 81 29 2 208 **032** = MINI N14 Engine

P/N 81 29 2 208 033 = Future use

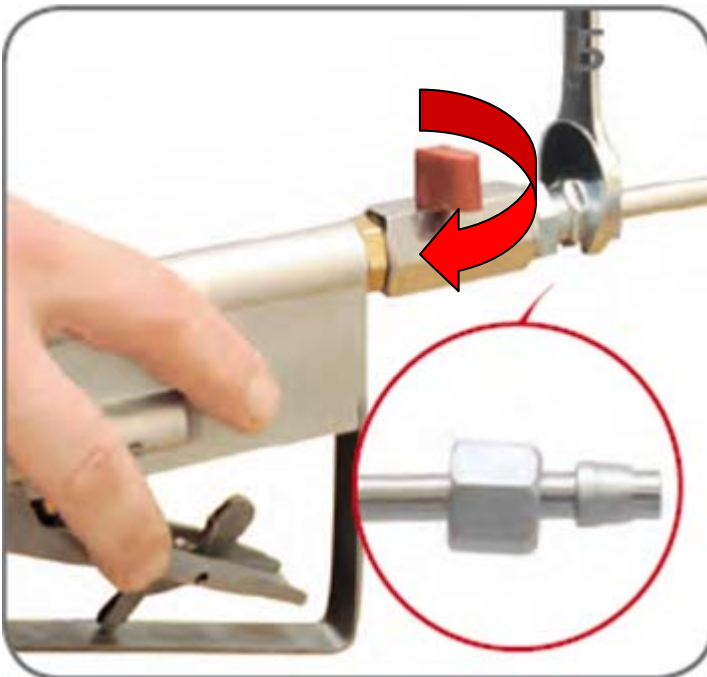

Attach the wand to the handle and securely tighten the nut.

When the tool is not in use, it is recommended to turn the two-way ball valve to the off position. The off position is shown in the illustration.

Trigger Operation Starting the Cleaning Process

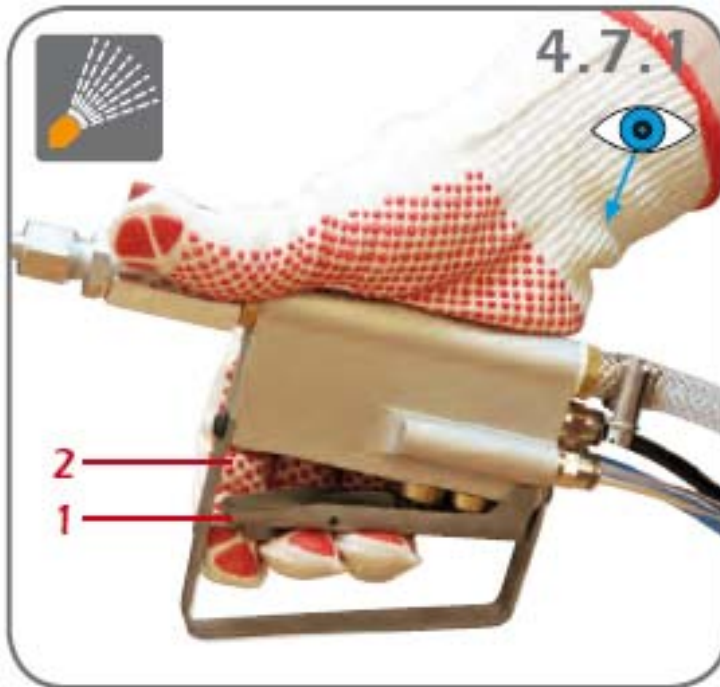

Familiarize yourself with the trigger operation with the shop air main supply valve in the off position and without the shop air connected to the carbon blaster.

The trigger has a safety lever. Flip the lever and slightly depress the trigger. When the trigger is moved to position 1, only shop air is allowed to exit the wand.



When the trigger is moved to position 2, both shop air and blasting material are allowed to exit the wand.

Blasting material exits the tool at very high velocity; do not use this tool in a fashion that is not described in this operating manual.

- Place cylinder number one of the engine in the TDC position. Use a TDC whistle or a wood dowel with the spark plug removed to determine that TDC has been reached.
- The intake valves of the cylinders must be 100% closed or the cylinder will fill with blasting material.



Turn on the vacuum.

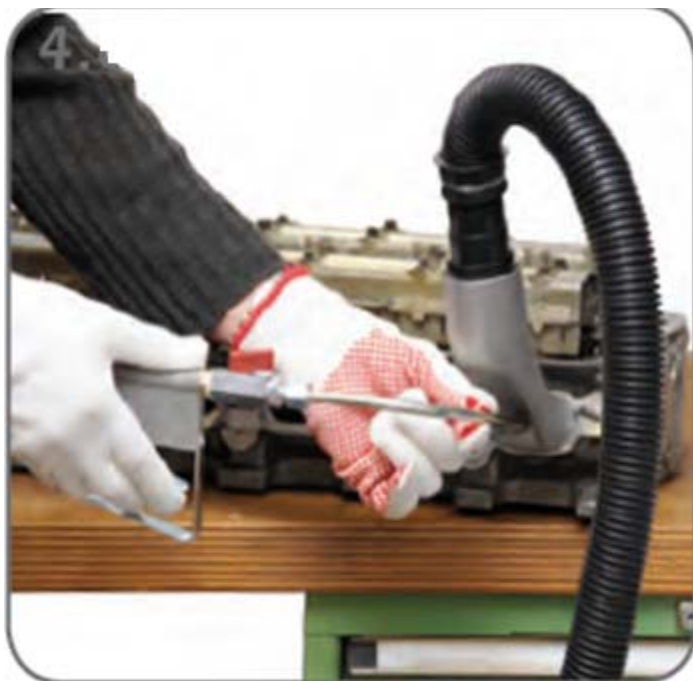

Insert the blasting wand into the cylinder head vacuum adaptor.

Note: For the purpose of clarity, some instructions may show the cylinder head removed from the vehicle. Do not remove the cylinder head from the vehicle.

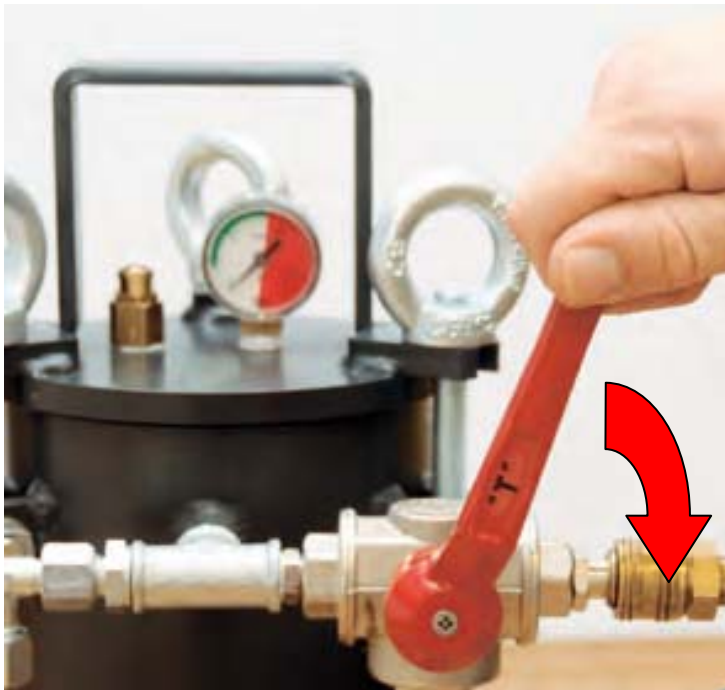

Turn the air supply valve to the “ON” position.

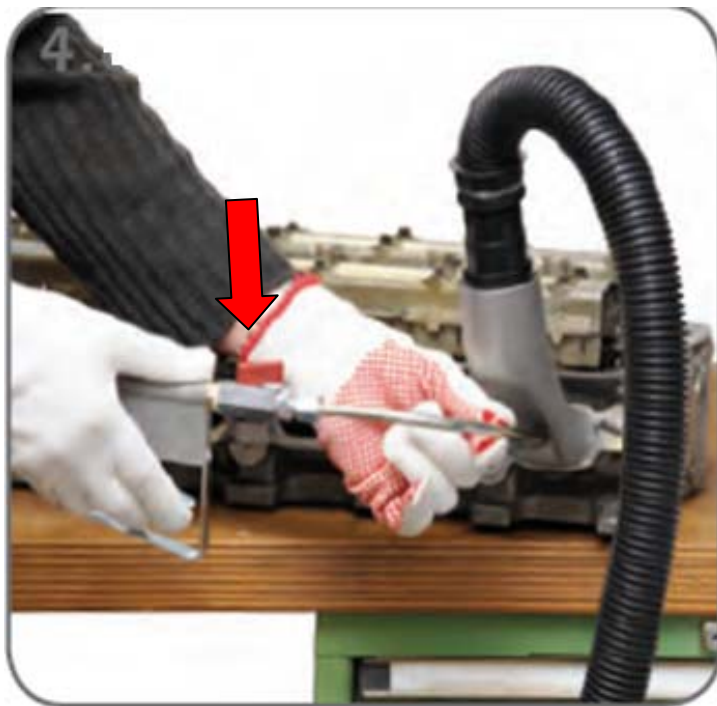

Turn on the wand two-way ball valve.

It is recommended that anytime the operator’s hands are removed from the handle, the wand two-way ball valve be closed for safety.

While blasting the carbon from the intake valves and the port, it is good practice to move the wand around, left and right, up and down, or in small circles to achieve the best cleaning results.

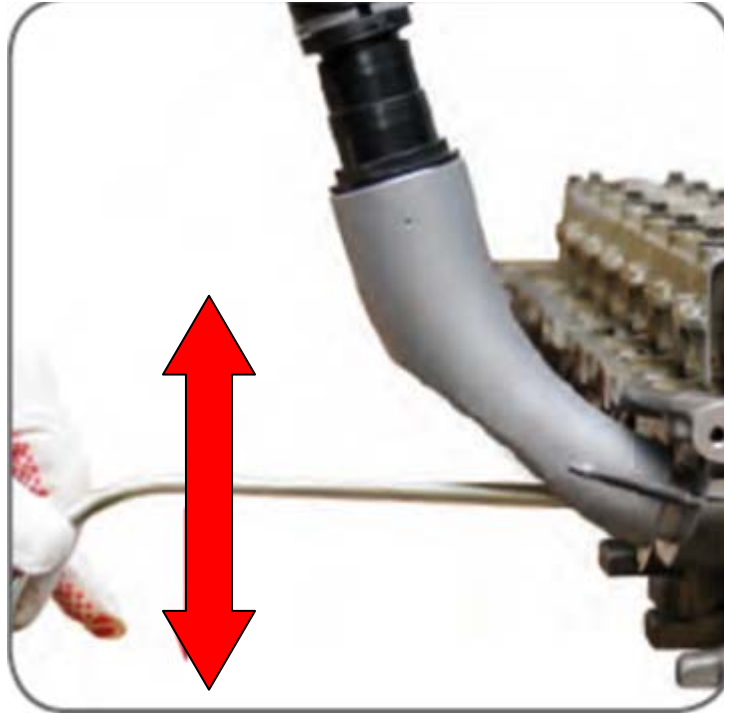

After approximately 30 seconds of blasting, release the trigger slightly to allow just shop air to enter the intake valve port. Continue to move the wand around to help evacuate the blasting material from the intake port. Depending on the amount of the carbon, you will have to repeat these steps several times to achieve clean results.

When you feel you have completed the cleaning, and before you remove the wand from the cylinder head vacuum adaptor, always turn off the wand two-way ball valve and shop air supply valve for safety.

If the results of your first inspection are not 100% clean, you will have to repeat these steps until the intake valves and the ports are clean. In some cases, you will have to use a pick tool to loosen stubborn carbon buildup.



The cleaning is complete once the valves and the ports are free of carbon and blasting material. Ensure that all blasting material has been removed, or engine damage can occur.



Repeat these steps for each of the cylinders. Each cylinder must be placed in the TDC position using a TDC whistle or a wood dowel with the spark plug removed, to determine that TDC has been reached.

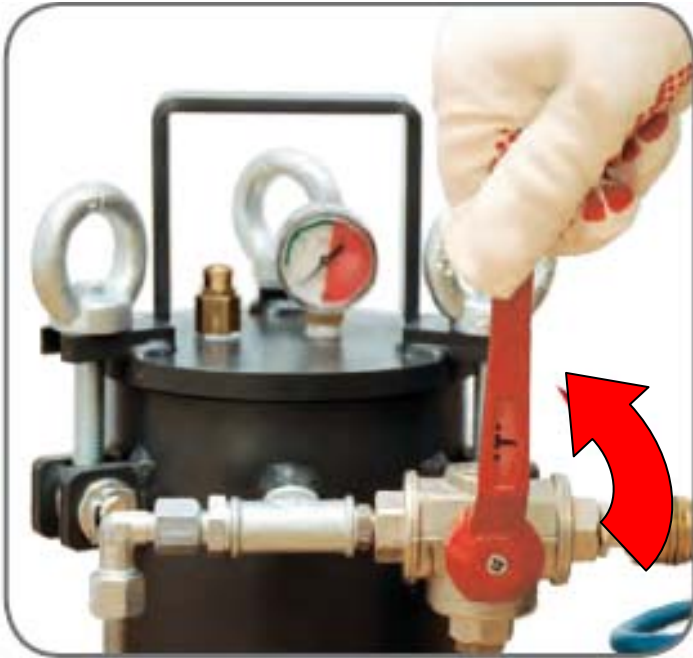

After cleaning all the intake valves and ports, turn off the air supply valve and disconnect the shop air supply line.



Allow the pressure to deplete inside the cylinder. The gauge must read zero before opening the lid.

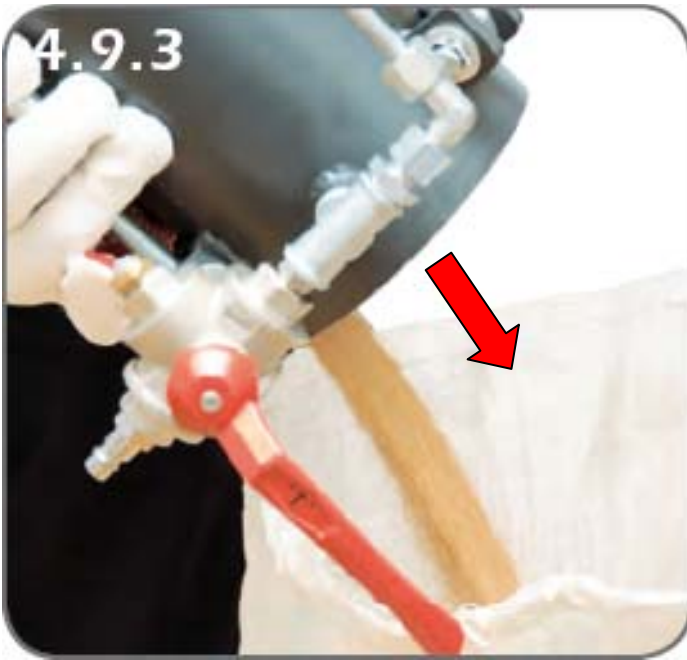

Remove unused blasting material and store it in a dry location.

It is recommended that the carbon blaster be stored in a dry location at room temperature. Abrupt changes in temperature can cause condensation inside the cylinder, resulting in the tool clogging.

Carbon Blaster Tool Maintenance:

The blasting material braided hose and brass nipples are subject to wear during operation, and must be checked for damage every two months and/or replaced at least once per year if the tool is used on a regular basis. This normal wear and tear is not covered under warranty.



Remove the protective cover from the hose bundle.



Disconnect the braided hose from the control valve.

Inspect the hose material for deterioration and, if necessary, replace at least once a year or more frequently, depending on tool usage.

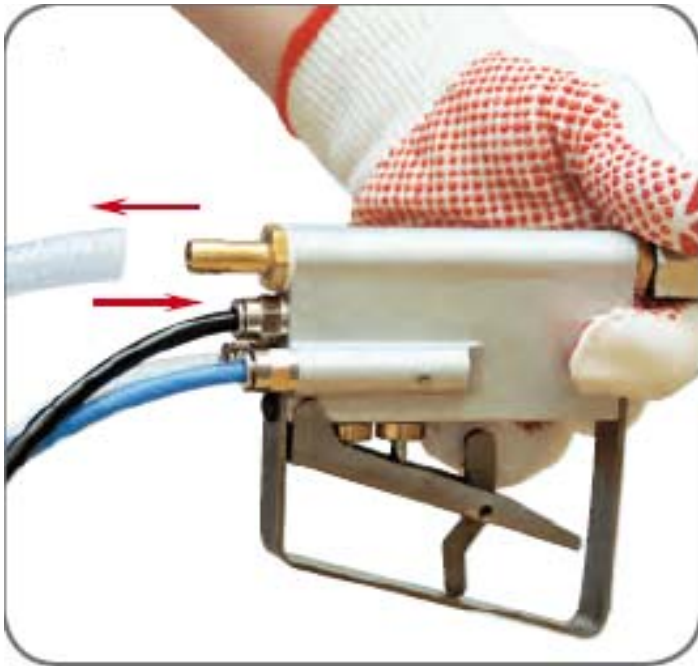

Disconnect the braided hose from the handle.

Inspect the hose material for deterioration and, if necessary, replace at least once a year or more frequently, depending on tool usage.

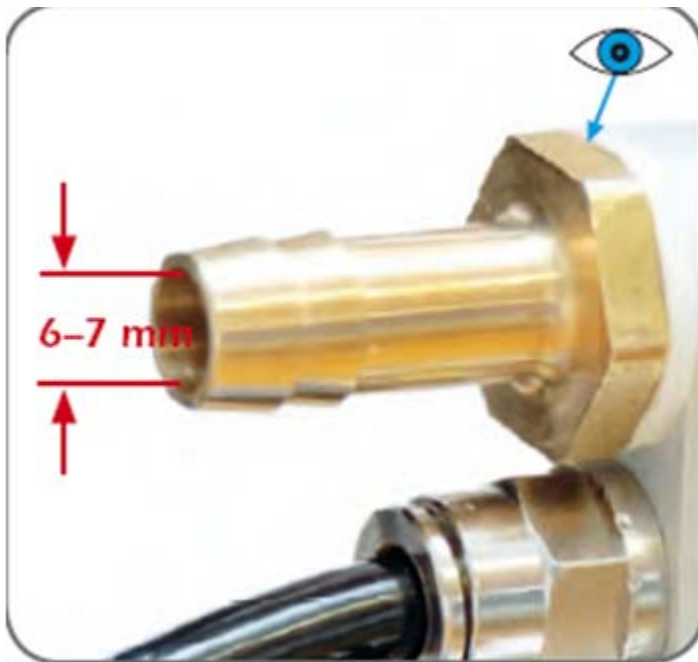

Inspect the brass barbed nipple on the handle and control valve.

Over time, the brass material will be worn away slightly by the blasting material. Measure the inside diameter of the brass nipple using a 7mm drill bit. If the 7mm drill bit fits inside the brass nipple, it must be replaced.

Original diameter = 6mm
Wear limit diameter = 7mm

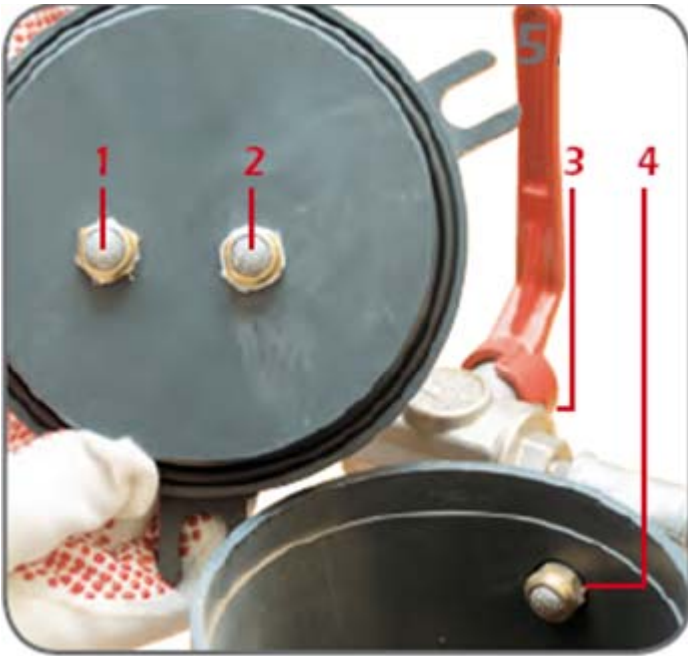

At regular intervals but after not more than 15 container fillings, the filter inserts need to be cleaned.

1. Filter in lid
2. Filter in lid
3. Filter in supply valve
4. Filter in cylinder

Remove all four filters, using a suitable tool.



Using compressed air, gently blow them out to release trapped material.

Always wear the recommended safety equipment described in the beginning of this manual.

Replacement media, 20/30 SAE or 0.45-0.80mm walnut shells can be sourced locally or through one of the following distributors:

MARCO® Corporate – 800 252 7848 Ext. 284 - marcousa.com/index.cfm

Trinity Tool Company - 800 587 4626 - www.trinco.com

McMASTER-CARR® - www.mcmaster.com

Replacement Parts, Warranty Information and Tool Overview:

All requests for warranty and service must be directed to:

WEZAG TOOLS, INC

Jared Essenpreis or Peter Herdeg

1490 W. Bernard Drive Suite B

Addison, IL 60101

630-953-8780 office

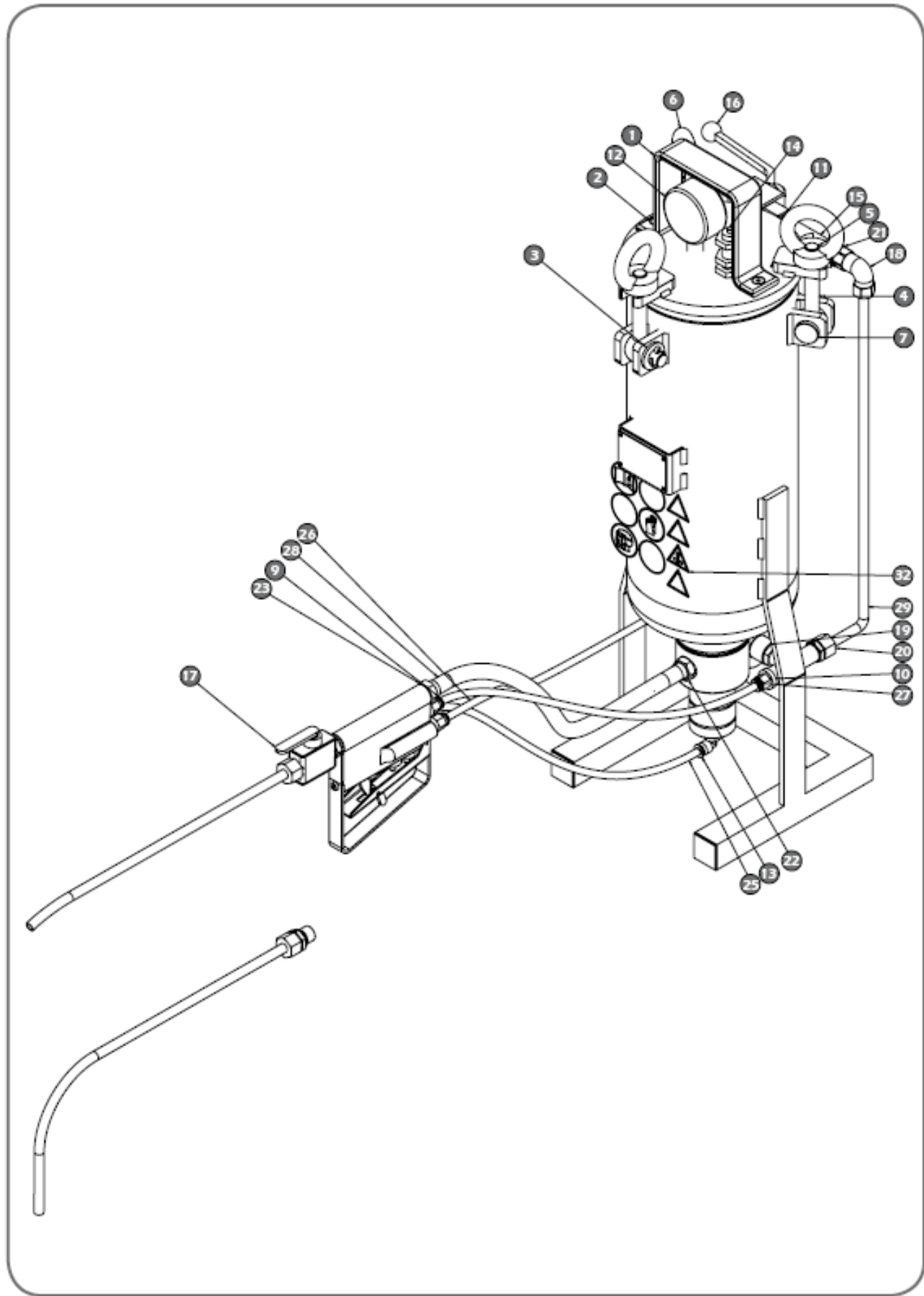

Item no.	Article number	Title
1	07-00000742	Ring nut
2	10-00000009	Exhaust valve G1/4 SW 16
3	10-00000011	GE G1/8" on Ø6
4	10-00000012	GE G1/4" on Ø6
5	10-00000017	Double nipple 1/4"
6	10-00000023	Pressure gauge
7	10-00000024	Angular connection 1/8" on Ø6
8	10-00000025	Safety valve
9	10-00000026	T-piece
10	10-00000027	3-way ball valve
11	10-00000028	2-way ball valve
12	10-00000029	Angular screw connection
13	10-00000030	Double nipple
14	10-00000031	Screw-in connection
15	10-00000032	Screw-in connection
16	10-00000034	Press nipple
17	10-00000035	Threaded grommet
18	12-00000184	O-ring
19	15-00000081	Blue hose
20	15-00000082	Black hose
21	15-00000083	Transparent hose
22	15-00000084	PVC hose
23	15-00000087	Ermeto tube 8x1
24	15-00000088	Protection tubing 20PP
25	50-00000307	Kapsto sealing screw
26	50-00000386	PVC disk for 1/4"connection
27	50-00000610	Kapsto plastic cover
28	50-00000643	Hose clamp
29	BGR-PNW-00000183	Nozzle, angled
30	BGR-PNW-00000184	Nozzle, straight
31	BGR-PNW-00000188	Control block
32	BGR-PNW-00000195	Handle