

**SUBJECT**
**Proper Diesel Exhaust Fluid (DEF) Level in SCR Reservoirs**
**MODEL**

E70 and E90 with M57Y

**SITUATION**

When checking the levels of the SCR system with ISTA/D, the active tank level reading shows 66%.

**CAUSE**

Level measurement strategy of the SCR system

**INFORMATION**

The level sensors in the passive and active SCR tanks do not continuously measure the DEF level. There are defined measurement points in the level sensor that the DDE control module uses to calculate the DEF level.

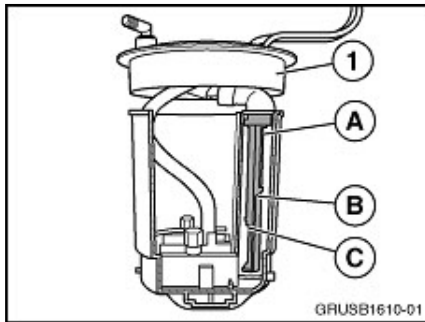

If the DEF level in the active tank (1) is above the full point (A) of the level sensor, the fluid level reading will be at 100% (full). Once the DEF level is below the full point of the level sensor, but still above the warning point (B), the level reading will be 66%. The warning scenario displayed to the customer will start to count down the mileage to "no start condition" when the DEF level is below the warning point (B), and above the empty point (C) of the sensor.

**RECOMMENDATION**

Do not overfill the SCR system. Filling the tanks up to the top of their respective filler necks will cause the DEF to leak out of the tank's vent system, and will possibly damage the tanks and internal components. All active and passive tanks are filled to the correct level at the factory. A tank level reading of 66% on a new vehicle requires no further action.

**Note:** Consult [SI B16 03 10](#) if a low exhaust fluid warning is displayed in a new vehicle with low mileage (5,000 miles or less).

**DEF Fill Capacities**

<b>E70</b>	<b>Capacity (Service)</b>	<b>Capacity (New Part)</b>
Active	5.5 liters	5.7 liters
Passive	15.8 liters	16.0 liters
<b>E90</b>	<b>Capacity (Service)</b>	<b>Capacity (New Part)</b>
Active	7.4 liters	7.6 liters
Passive	12.7 liters	12.95 liters

**WARRANTY INFORMATION**

For information only

[ Copyright © 2010 BMW of North America, LLC ]