

REP-REP-RAE7011M57T2-1171100_SCR Removing and installing or replacing the exhaust-gas recirculation cooler (M57T2-SCR)

VIN: **XXXXXXX** Vehicle: **3'/E90/SEDAN/335d/M57/AUTO/EUR/LL/2006/03**
System **3.51.25.14849** Data **R3.51.25.14849**
Version: Version:

11 71 100

Removing and installing or replacing the exhaust-gas recirculation cooler (M57T2-SCR)



Important!

When working on the oil, coolant or fuel circuit, you must protect the alternator against dirt contamination.

Cover alternator and **belt drive** with suitable apparatus.



Necessary preliminary tasks:

- Remove [acoustic cover](#)
- Remove [fan cowl](#).
- [Drain](#) coolant from radiator.
- Remove [intake silencer housing](#).

Release clamp (1) from exhaust-gas recirculation cooler.

Installation note:

[Tightening torque 11 71 5AZ.](#)

Disconnect connector (2).

Turn plug socket counterclockwise and remove in upward direction from holder.

Installation note:

If replacing, modify exhaust-gas

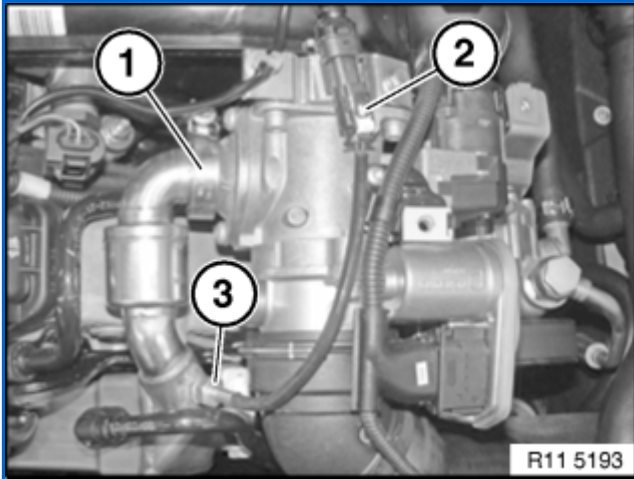

temperature sensor (3).
Tightening torque [11 71 7AZ](#).

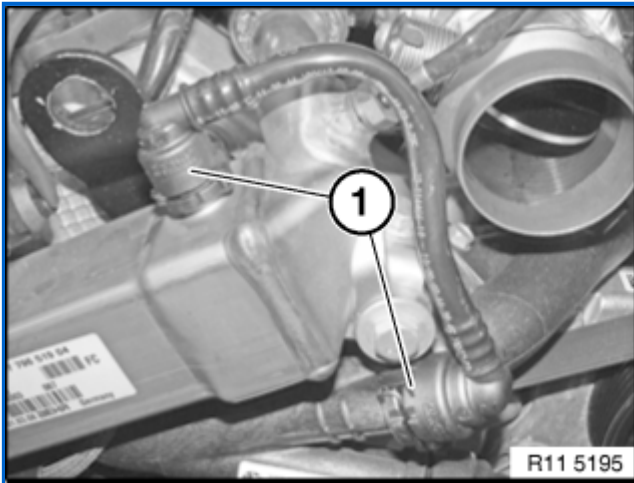

Follow notes for repair work on the cooling system.
Unlock and detach coolant hose (1).

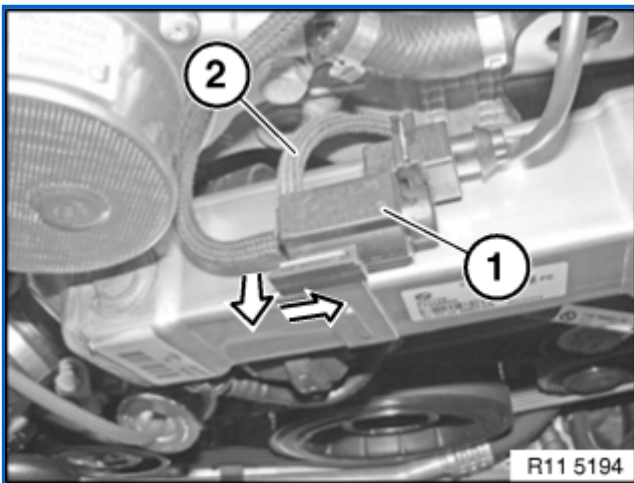

Gently pull clip from electric changeover valve (1) towards front and slide away to right side.

Release screws (1) on the exhaust-gas recirculation cooler/manifold.

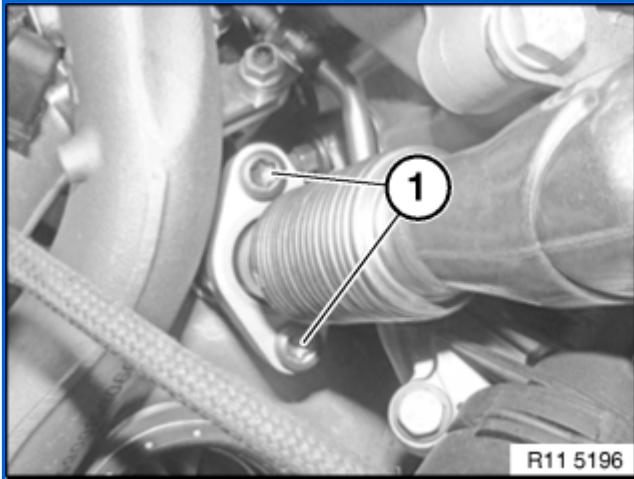

Installation note:
Tightening torque [11 71 4AZ](#).

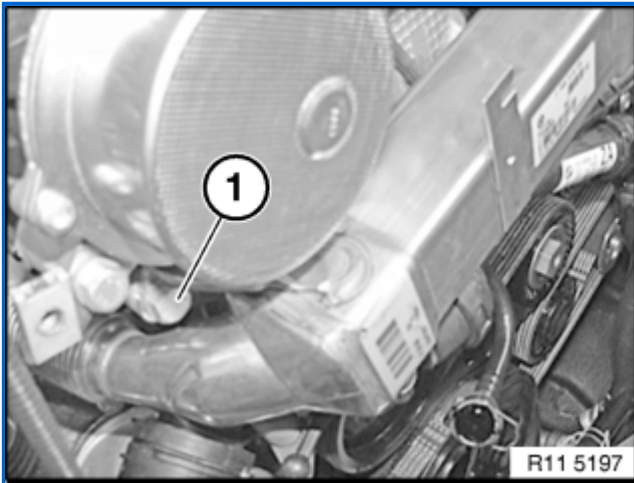

Unfasten screw (1)
Installation note:
Tightening torque [11 71 6AZ](#).

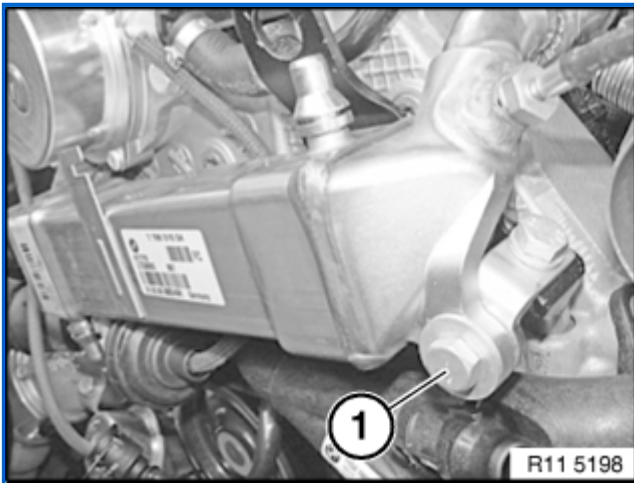

Release bolt (1) and remove exhaust-gas recirculation cooler.
Installation note:
Replace screw.
Tightening torque [11 71 6AZ](#).

Installation note:
Observe tightening sequence.

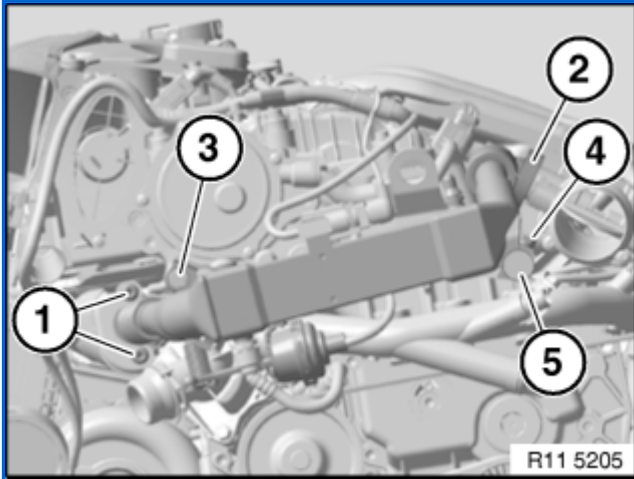

1. Join bolts (3, 4 and 5).
Tightening torque [11 71 6AZ](#).
2. Release bolts (3, 4 and 5) back by 90°.
3. Secure screws (1).
Tightening torque [11 71 4AZ](#).
4. Secure profile clamp (2).
Tightening torque [11 71 5AZ](#).
5. Tighten screw (3).
Tightening torque [11 71 6AZ](#).
6. Secure bolt (4) on holder.
Tightening torque [11 71 6AZ](#).
7. Secure microencapsulated screw (5).
Tightening torque [11 71 6AZ](#).



Installation note:
[Top up coolant.](#)