

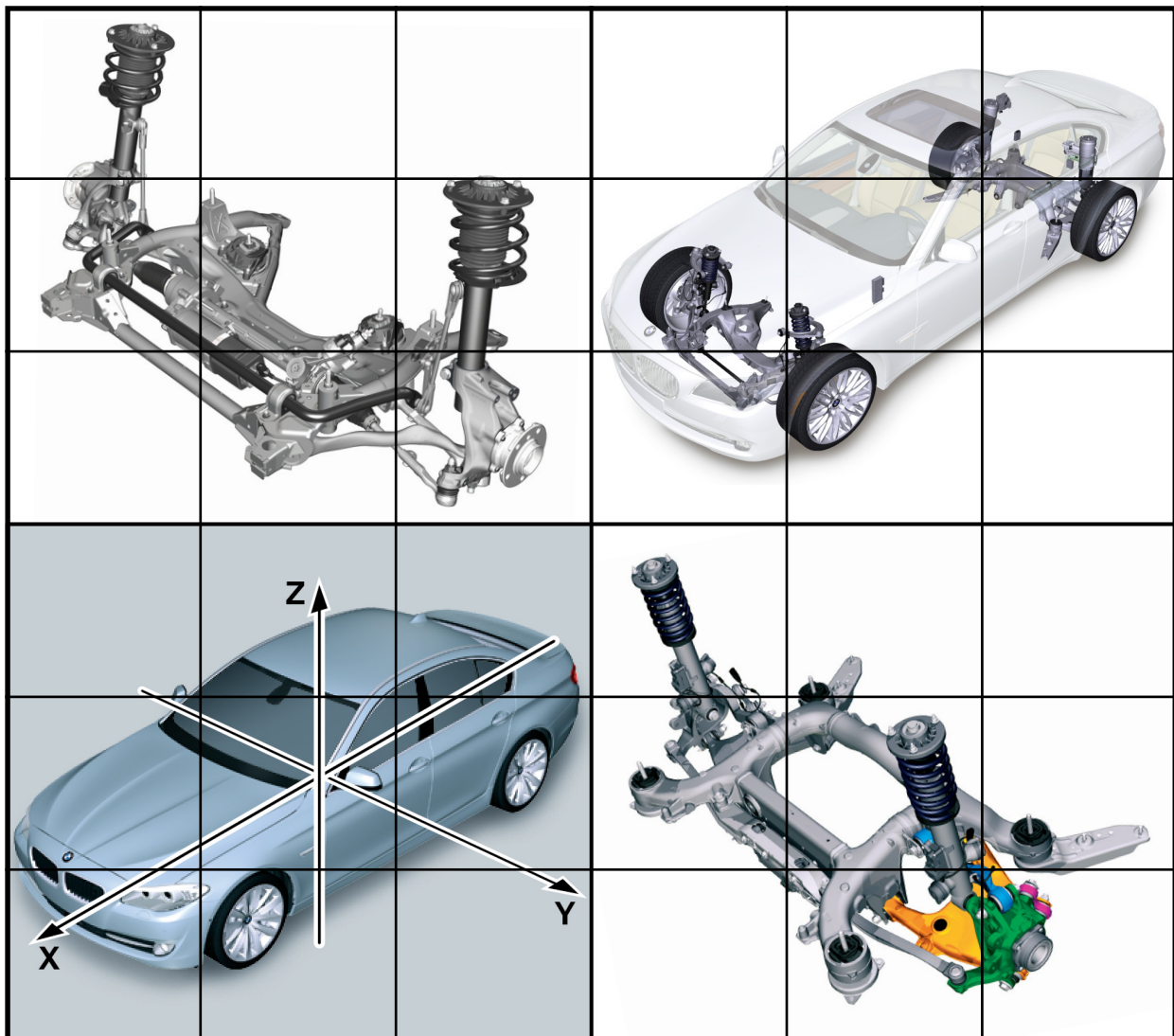

BMW Technical Training

Chassis Dynamics



Information Status: August 01, 2012

Course Code: ST1115 Chassis Dynamics

The information contained in the training course materials is solely intended for participants in this training course conducted by BMW Group Technical Training Centers, or BMW Group Contract Training Facilities.

This training manual or any attached publication is not intended to be a complete and all inclusive source for repair and maintenance data. It is only part of a training information system designed to assure that uniform procedures and information are presented to all participants.

For changes/additions to the technical data, repair procedures, please refer to the current information issued by BMW of North America, LLC, Technical Service Department.

This information is available by accessing TIS at www.bmwcenternet.com.

Table of Contents

Lateral Dynamics (Y Axis)

Subject	Page
Introduction	5
Steering Fundamentals	6
Steering Ratio	6
Steering System Types	8
Recirculating-Ball Steering	8
Rack-and-Pinion Steering	9
Electric Power Steering (EPS)	10
Versions of Electric Power Steering	11
Column Mounted EPS	12
System Components	13
EPS with APA	15
Distinction from Active Steering	15
Features of Electric Power Steering	17
Improved Handling Dynamics	17
Greater Driving Comfort	17
Greater Driving Safety	17
Better Environmental Credentials	17
Simplifications for the Vehicle Manufacturer	17
System Overview	18
EPS System Circuit Diagram	20
System Components	21
Steering Torque Sensor	21
EPS Control Unit	22
Electric Motor with Position Sensor	23
Reduction Gear	25
Steering Rack	27

Subject	Page
Principles of Operation	28
EPS Input Variables	29
EPS Output Variables	30
DME Functions Used by EPS	31
Intelligent Alternator Control	31
Speed-Dependent Power Steering Assistance	32
Active Steering Wheel Return	33
Active Damping	35
Damping Roadwheel Feedback	35
Damping Steering Input from Driver	35
Damping of Steering Input by EPS	36
Active Roadwheel Feedback	37
Control	37
Status Shutdown in the Event of Faults	38
Coordination of Specified Settings	39
Supplementary Functions	39
Protection Against Overload	39
End Stop as Software Function	40
Service Information	41
Replacing an EPS System	41
Intelligent Alternator Control and EPS	41
Active Steering Wheel Reset	41
Protection Against Overload	41
Step-down Gear	42
Shutdown in the Event of Faults	42
Electrical Connections	42
EPS System (FXx)	43
Basic Steering	44
System Overview	46
Active Steering	50
EPS with 12V	52
EPS with 24V	54
24V EPS System Components	54
24V EPS and Active Steering Wiring Diagram	56
Variable Sport Steering	62
F25 Steering Angle Sensor	64
F25 EPS Wiring Diagram	65

Subject	Page
Integral Active Steering66
Overview69
Signals from External Sensors70
Control and Modulation of Steering71
Distributed Functions72
Components of Integral Active Steering w/ Hydraulic Steering74
Rear Axle Steering Control75
Functions of Integral Active Steering78
Low Speed Range78
High Speed Range80
Handling Stabilization by IAL when Understeering82
Handling Stabilization by Integral Active Steering Under μ -split	
Braking Conditions83
Integral Active Steering Special Function85
Automatic Snow Chain Detection85
Active Steering (AS)86
Changes to Active Steering87
Cumulative (total) Steering Angle (virtual)87
Electronically Controlled Bypass Valve (EVV)87
Yaw-Rate Control Plus (GRR+)89
Special Feature90
Difference to Yaw Moment Compensation90

Lateral Dynamics (Y Axis)

Model: 5 and 6 Series (E6X), 3 Series (E9X)

Production: From Start of Production

OBJECTIVES

After completion of this module you will be able to:

- Understand Steering Ratio
- Understand the Concept of Active Steering
- Identify and Locate Active Steering Components
- Diagnose Concerns on Active Steering Systems
- Perform Alignments on Vehicles Equipped with Active Steering

Introduction

At BMW, steering systems have become an increasingly complex topic. This training module is designed to review basic steering technology and to introduce the latest technology used in current BMW models.

A steering system must be able to convert a turning motion input by the driver at the steering wheel into a change of steering angle at the steered wheels on the vehicle. This is the essential requirement of a steering system irrespective of whether it is a simple, conventional steering system or the latest modern BMW Group steering system.



Steering systems must have the following characteristics:

- The construction of the steering gearbox/ rack and pinion must enable the vehicle to respond to the slightest steering adjustments.
- When the steering wheel is released, the wheels must return to the center position (straight-ahead travel).
- The steering geometry must follow the Ackermann rule, i.e. when the left and right wheels are at full lock, the extension of the wheel axes must intersect the extension of the rear axle.
- The steering system must compensate for uneven road surfaces while ensuring that the driver remains in control.
- To achieve the best possible handling, the steering system must have a low steering ratio (i.e. number of steering wheel turns from lock to lock).

Steering Fundamentals

Steering Ratio

In order to better understand basic steering theory it is necessary to understand steering ratio. Steering ratio is the relationship between the number of turns of the steering wheel in comparison to the amount of steering angle change that occurs at the front wheels.

For example, if the steering wheel is turned through 360 degrees of rotation and the front wheels turn through an arc of 20 degrees, the steering ratio is therefore 18:1. In other words, it takes 18 degrees of steering wheel rotation to achieve 1 degree of steering movement at the front wheels.



A “high” steering ratio (which is less direct) such as 18:1 dictates that a large amount of steering input is required to steer the vehicle through turns. A ratio of 18:1 is good for high road speeds. This is due to the fact that there would be no excessive movement of the front wheels when making lane changes. Therefore, a numerically “high-ratio” is optimal for higher road speeds.

In contrast, when driving a lower speeds such as parking, a “low-ratio” steering , such as 10:1, would be better. Less input at the steering wheel would aid parking and be more comfortable for the driver. Also, low speed maneuvers such as low speed corners or avoiding road debris would be greatly improved. A “low-ratio” is also referred to as a “more direct” steering ratio.

Vehicles designed for racing, such as Formula 1 cars, use a “low-ratio” steering setup. These types of vehicles would not benefit from a higher steering ratio. Tight, high-speed turns require a “quick” response from the steering system.



In order to achieve the “best of both worlds”, some BMW vehicles have been equipped with a “variable-ratio” rack and pinion steering system. This is a purely mechanical system which uses a rack and pinion unit that has teeth of different “pitch” throughout the length of the rack gear.

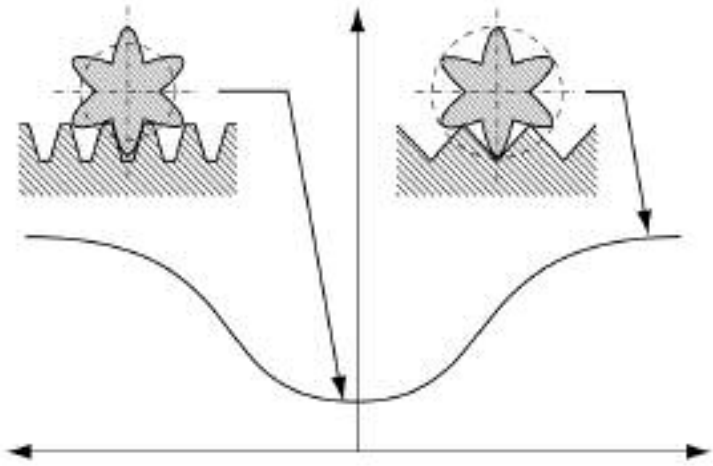

The teeth on the outer ends of the rack gear are more tightly spaced and the teeth in the center of the rack gear are more loosely spaced. This gives the effect of a “high-ratio” (less direct) when driving on the highway. At low speeds when more turning angle is required, the teeth on the outer end of the rack allow for a “lower-ratio” (more direct) steering which is more responsive during the required maneuvers.

Steering System Types

As far as steering systems are concerned, they are two basic types of steering mechanisms used on BMW Group vehicles. These include the following:

- Recirculating-ball steering - This is also known as “ball and nut” or the more common term being “steering box”. This arrangement has been in use on early models usually the 5 and 7 series. The last vehicles in production to use this type of steering arrangement was the E38 and E39. The 8-cylinder E39 (540i) utilized the steering box, while the 6-cylinder E39 (528i/530i etc.) use a “rack and pinion” steering design.
- Rack and Pinion steering - The more common steering gear design is the rack and pinion which is more versatile and lighter in weight. This is used on all current BMW models.

Recirculating-Ball Steering

A low friction endless row of balls transmits forces between the steering worm and steering nut. The steering nut exerts a force on the steering shaft via gear teeth. A variable ratio is also possible with this steering gear.

An extensive and wide-ranging development history lies behind the modern steering systems used nowadays incorporating power steering assistance.

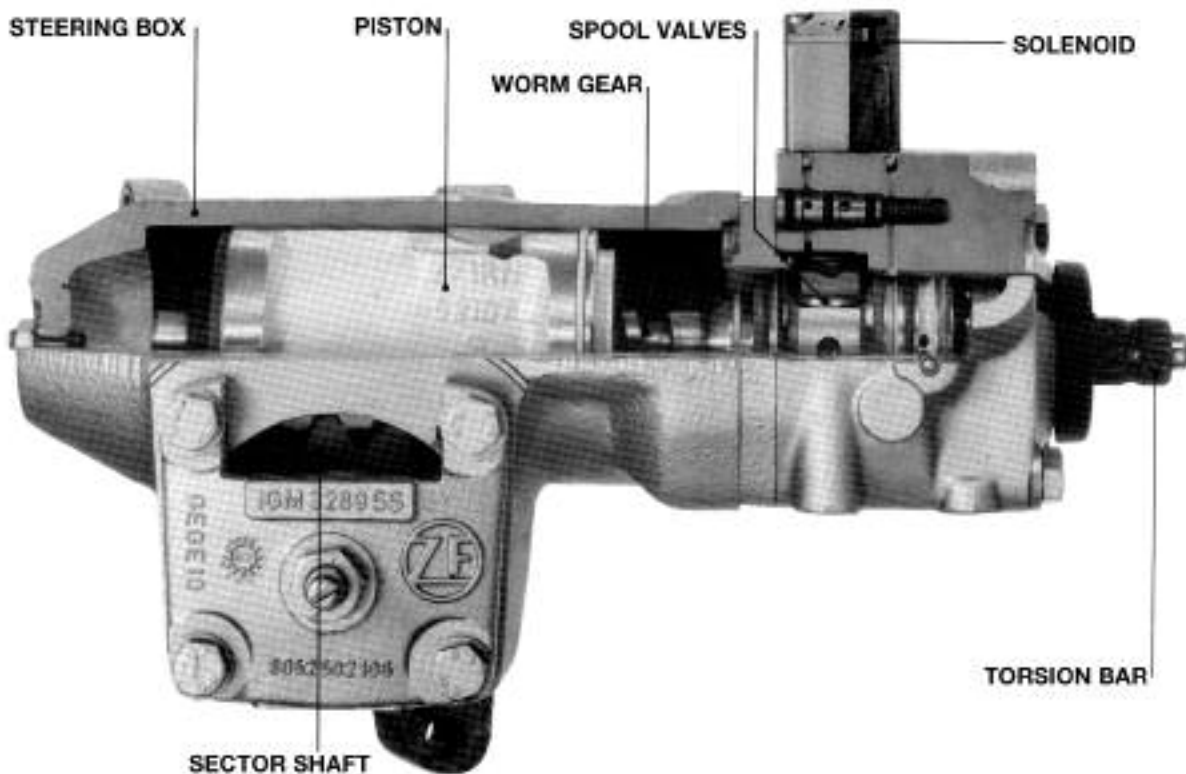

Electric Power Steering (EPS)

The main difference between hydraulic and electric power steering systems is in the method of generating the power assistance force that reduces the amount of force that the driver has to apply to the steering wheel.

With a conventional power assisted (hydraulic) steering system, a pump is driven either by a belt running off the engine or by an electric motor. The pump is part of a hydraulic system which generates the fluid pressure/flow that is used to produce the power assistance for steering. A control valve in the power steering rack varies the pressure to decrease the effort required to turn the steering gear.

On some BMW vehicles, this control pressure is reduced by increasing vehicle speed via an electronically controlled bleed off valve (Servotronic). However; hydraulic power assisted steering systems utilize a reservoir, hydraulic fluid, pump, hoses/lines, cooler, hydraulic valve/steering rack, Servotronic valve, purpose built steering shaft and column.

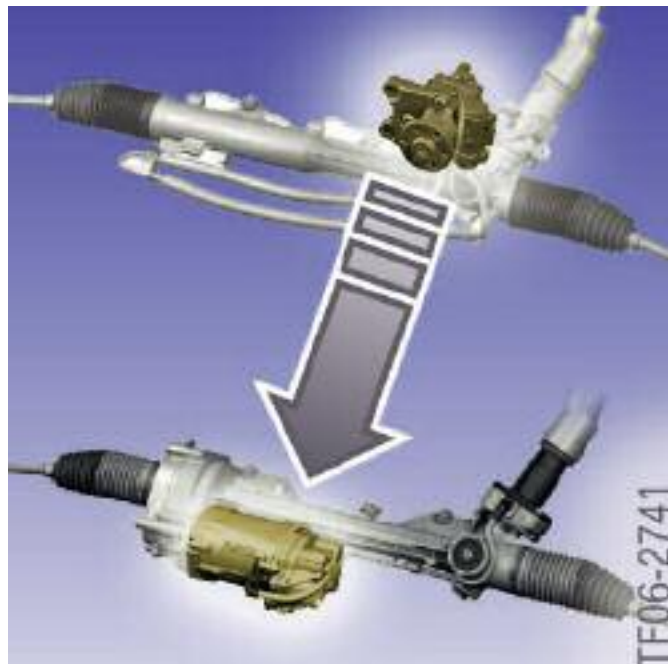

Electric power steering systems produce the power assistance force directly by means of an electric motor that transmits its torque either to the steering column or the steering gear. Therefore, such systems generally require extra gearing to connect the electric motor to the existing steering system components.

Otherwise, the basic design of the steering system is the same (e.g. rack-and-pinion steering gear for both hydraulic and electric power steering systems).

The steering characteristics, e.g. amount of steering force required, progression of steering force, feedback from the road, are subject to strict development specifications that have resulted in continual optimization of the hydraulic power steering systems so far used. The new electric power steering systems have to match up to the outstanding steering characteristics of BMW vehicles that BMW owners have come to experience.

Versions of Electric Power Steering

The table below categorizes EPS systems on the basis of the mounting position of the servo unit consisting of electric motor and reduction gearing. With the advent of EPS, the method of generating the power assistance for steering changes from hydraulic to electrical means.

Index	EPS with APA	C-EPS
Vehicles	Z4 (E89)	Z4 (E85, E86)
Manufacturer	ZF	ZF
Type of Motor	Brushless Motor	Brushless Asynchronous Motor
Location of Motor and Reduction Mechanism	Parallel to Steering Rack	Upper Part of Steering Column Inside Passenger Compartment
Design of Reduction Mechanism	Belt and Ball Screw Drive	Worm Shaft and Gear

EPS with APA refers to the electric power steering with axial parallel arrangement or the location of the motor on the rack and pinion versus the column mounted motor (C-EPS) system used on E85/E86



E89 EPS with APA System



E85 C-EPS System

Column Mounted EPS

Electric Power Steering (EPS) was used for the first time by BMW in the E85 Z4. It provides the typical BMW power assisted steering characteristics and “feel”. The EPS is a very direct, sporty steering element with a change-over between normal and “Sport” mode by the Dynamic Driving Control (Sport) button.

The EPS system in the E85/E86 differs from the conventional hydraulic power assisted steering system by utilizing a column mounted servo unit (motor) and electrical/electronic components to provide power assisted steering while retaining a complete mechanical connection. The EPS is a "dry system", the hydraulic components and oil are not required.

The programmed EPS control functions are influenced by vehicle speed and provide additional benefits regarding steering tuning, absorption adjustments and active steering return characteristics.

The advantages of EPS are:

- Reduces CO2 emissions
- Less power consumption
- Less maintenance and assembly
- Improved driving dynamics
- Increased comfort
- Increased driving safety
- Weight reduction
- Environmentally friendly (Less oil leaks)

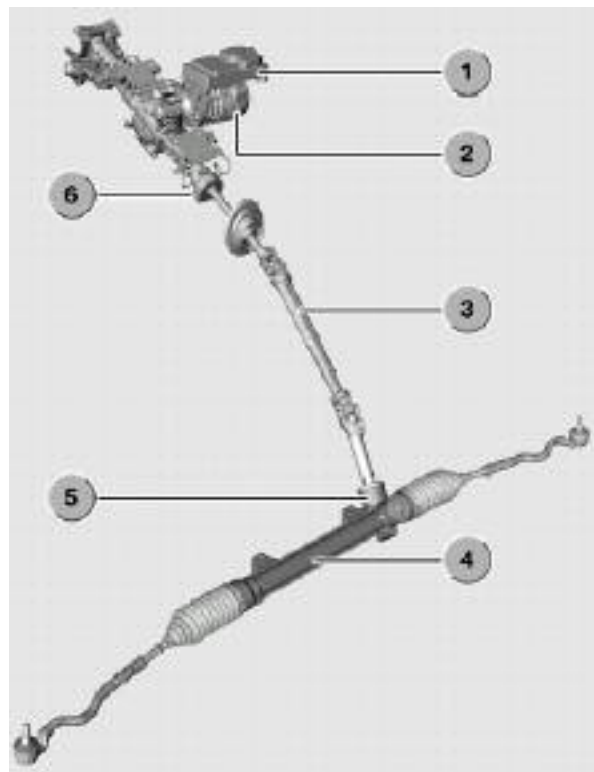

Index	Explanation	Index	Explanation
1	EPS Control Module	4	Steering Rack
2	EPS Electric Motor	5	Steering Gears
3	Lower Steering Column	6	Steering Angle Sensor

Improved Driving Dynamics:

- The EPS Electric Motor provides good power assisted steering control characteristics.
- Active return to center.
- Switchable steering characteristic (Dynamic Driving Control).
- Use of light weight sport steering wheels (1kg less than other steering wheels).

Increased Driving Comfort:

- Decouples unnecessary steering oscillations (from road disturbances) while maintaining relevant road feel information (different road conditions) to the driver.
- Speed dependent steering assist force (parking vs. high speed driving).

Increased Driving Safety:

- EPS provides a direct mechanical connection to the steering gear, conveying direct road.
- Feel.
- Speed dependent steering actively absorbs left/right roll.

Increased Environmental Compatibility:

- Reduced fuel and engine power consumption
- Leak free "dry system"

System Components

The EPS system is divided into 3 component groups:

- Upper steering column assembly
- Steering gear with rack
- Lower steering spindle

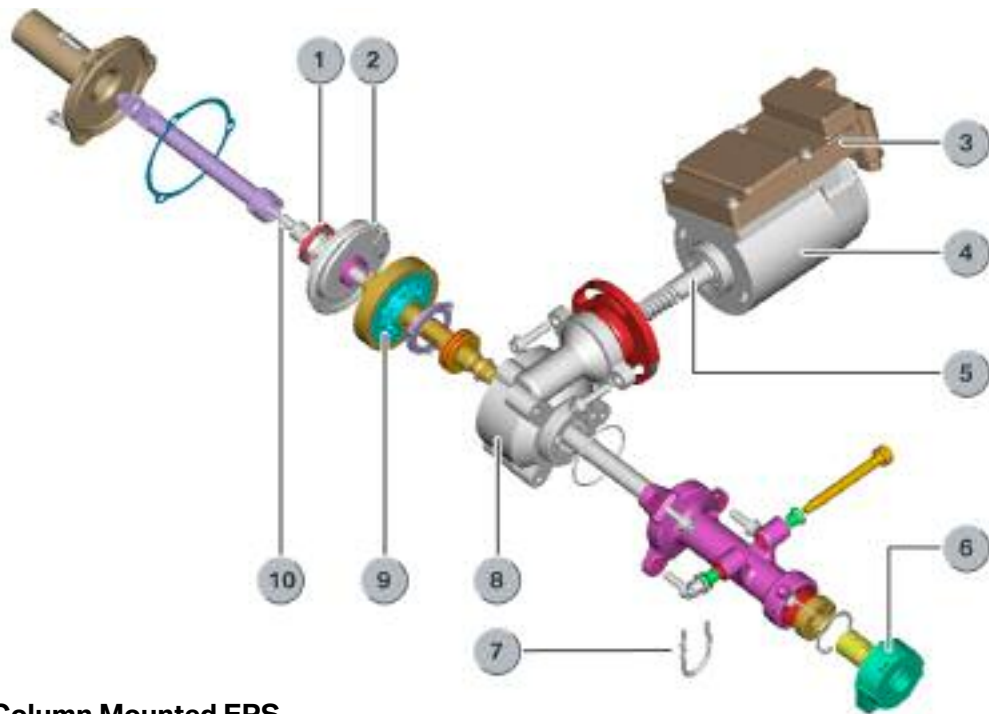

E85 / E86 Column Mounted EPS

Index	Explanation	Index	Explanation
1	Magnet Wheel	6	Steering angle sensor
2	Steering torque sensor	7	Shipping/service steering locking pin. Must remove after installing column.
3	ESP control module	8	EPS housing
4	Electric motor	9	Driven gear
5	Worm gear shaft	10	Torsion bar

The electric motor and the worm gear in the servo unit produce a new acoustic pattern in the passenger compartment.

The system acoustics can be heard in particular situations:

- When the steering wheel is spun quickly
- When the steering wheel is turned while the car is stationary
- When the steering wheel is turned in a quiet atmosphere (e.g. radio not turned on)

This acoustic pattern is not a system fault. The conventional sounds generated by hydraulic steering systems (pump modulation, limiting valve) are eliminated.



The EPS Control Module cannot be replaced separately, the entire assembly with the exception of the Steering Angle Sensor must be replaced as a unit (VIN specific part #).

EPS with APA

The use of electric power steering with axial parallel arrangement provides many advantages for the BMW customer, the environment and the BMW Group.

Interacting with the well-proven suspension concepts, a unique combination of driving comfort and dynamics is achieved. The steering properties (e.g. the level of steering torque assistance and damping) can be finely tuned by correspondingly programming the electrical system while ensuring optimum adaptation to the different vehicle philosophies.

Thus, despite the use of identical mechanical components, the system will be capable of perfect adaptation to future BMW models.

Where more precise steering and better handling characteristics are desired for a more sports-style model, it can be achieved by reducing the amount of power assistance.

Although the driver then has to apply slightly more force to the steering wheel, the feedback from the roadwheels gives the more "direct" feel desired.

By contrast, a greater degree of power assistance can be programmed for models whose steering characteristics are to be more comfort-orientated.

With the disappearance of the hydraulic system (consisting of pump, hoses, cooler, fluid, etc.), assembly of the steering on the production line is more efficient for the manufacturer. The EPS steering system is supplied as a pre-assembled unit and fitted to the vehicle as such. In addition, the EPS also eliminates the environmental hazard of hydraulic fluid leakage.

Distinction from Active Steering

The electric motor of an EPS system is capable of superimposing additional force in addition to the force applied by the driver. The EPS is able to determine the level and timing of that force independently of such factors as the engine speed.

The rigid link between the steering wheel and the front wheels remains unchanged with electric power steering. The gear ratio of the rack is fixed, so the position of the steering wheel is always directly related to the position of the front wheels.

The electric motor in an active steering system, by contrast, is capable of superimposing a steering angle (which changes the ratio between steering wheel and front wheels) but not a steering force.

The steering train of an active steering system is split by a double planetary gear. This enables the active steering to alter the steering angle of the roadwheels without it being felt by the driver through the steering wheel.

In order for the wheels to adopt the total steering angle produced by the steering wheel position plus the superimposed adjustment, a bracing force is required: the driver has to hold the steering wheel firmly. A pump unit is also required. This can only be of the hydraulic type on active steering systems. Only hydraulic pump units are currently capable of providing the combination of high positioning force and positioning speed.

Because the electric motor is activated only when required (when steering but not when driving straight ahead) fuel consumption is reduced and the effective power output of the combustion engine increased when compared to a conventional hydraulic power steering system.

The example figures below illustrate the difference in power consumption between the two steering systems.

Power Consumption	Electric Power Steering	Hydraulic Power Steering
Minimum Demand	10 Watts	300 - 400
Maximum Demand	1,000 Watts	2,000

Features of Electric Power Steering

Improved Handling Dynamics

- Steering characteristics perfectly adapted to vehicle model
- Active return to center
- Linear dynamics benefits of up to 2 kW

Greater Driving Comfort

- Steering train isolated from suspension vibration while still transmitting the important road feedback (different road surface conditions) to the driver.
- Improved isolation of interference from the road surface (less steering judder).
- Electronically controlled, speed-dependent power-assistance (e.g. greater when parking).

Greater Driving Safety

- Servotronic function: EPS assists the driver to hold the correct line, particularly at high speeds, by providing a lower level of power assistance than at low speeds.
- Steering wheel backlash is reduced by active speed-dependent damping. This function also reduces the vehicle's tendency to slew in response to abrupt steering wheel movements made by the driver.

Better Environmental Credentials

- Fuel saving of approx. 0.2 l per 100 km
- No possibility of leakage from the hydraulic system

Simplifications for the Vehicle Manufacturer

- Reduced assembly and inspection complexity at the production plant as the system is supplied as a complete unit.
- Reduced range of variants compared to hydraulic systems (pumps, hoses, steering wheels).
- Easier tuning of power steering assistance by programming.
- High future potential: integration between vehicle systems (dynamic driving systems, driver assistance systems).

System Overview

The electric power steering is an absolutely identical fit with the previously used hydraulic power steering as far as the connections between it and the vehicle are concerned.

For comparison, a hydraulic power steering system and the new EPS with parallel mounted motor are illustrated below.



Index	Explanation
1	Hydraulic-fluid reservoir
2	Steering column
3	Torsion bar and valve actuator
4	Track rod
5	Hydraulic power steering pump
6	Steering rack

Hydraulic Power Steering (typical installation configuration)



Index	Explanation
1	Steering rack
2	Steering torque sensor
3	Steering column
4	Track rod
5	EPS control unit
6	Electric motor with position sensor
7	Reduction gear

Electric Power Steering with Parallel-mounted Motor

The EPS system essentially consists of the following components:

- Steering torque sensor
- EPS control unit
- Electric motor with position sensor
- Reduction gear
- Steering rack

EPS Rack-and-Pinion Steering Box with Parallel-mounted Electric Motor

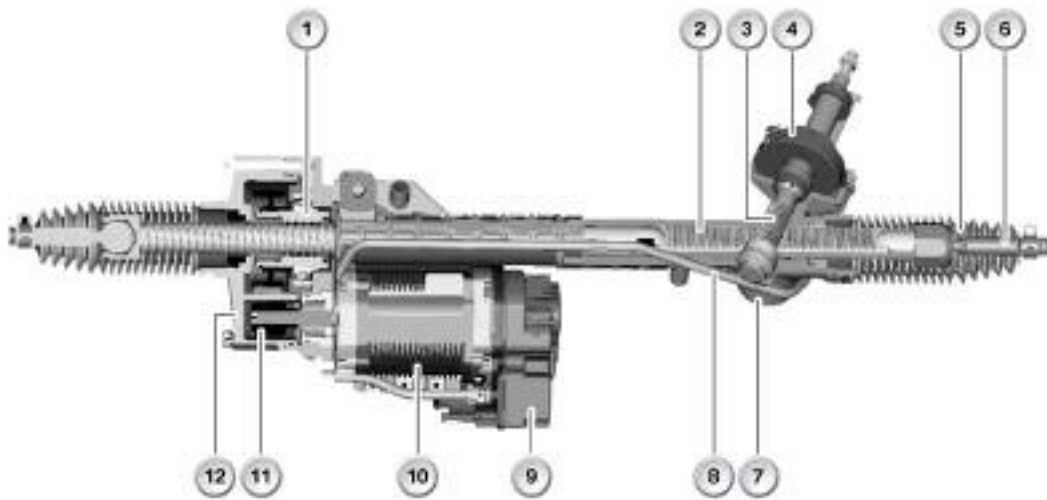

Index	Explanation	Index	Explanation
1	Ball-screw drive (part of reduction gearing)	7	Thrust piece
2	Rack	8	Signal and power lead for steering torque sensor
3	Pinion	9	EPS control unit
4	Steering torque sensor	10	Electric motor
5	Gaiter	11	Toothed-belt drive (part of reduction gearing)
6	Track rod	12	Reduction-gear housing



These components form a pre-assembled unit (often referred to as "EPS steering rack assembly") that can only be replaced as a complete unit. To do so, the unit has to be disconnected from the tie rods and the lower end of the steering column.

EPS System Circuit Diagram

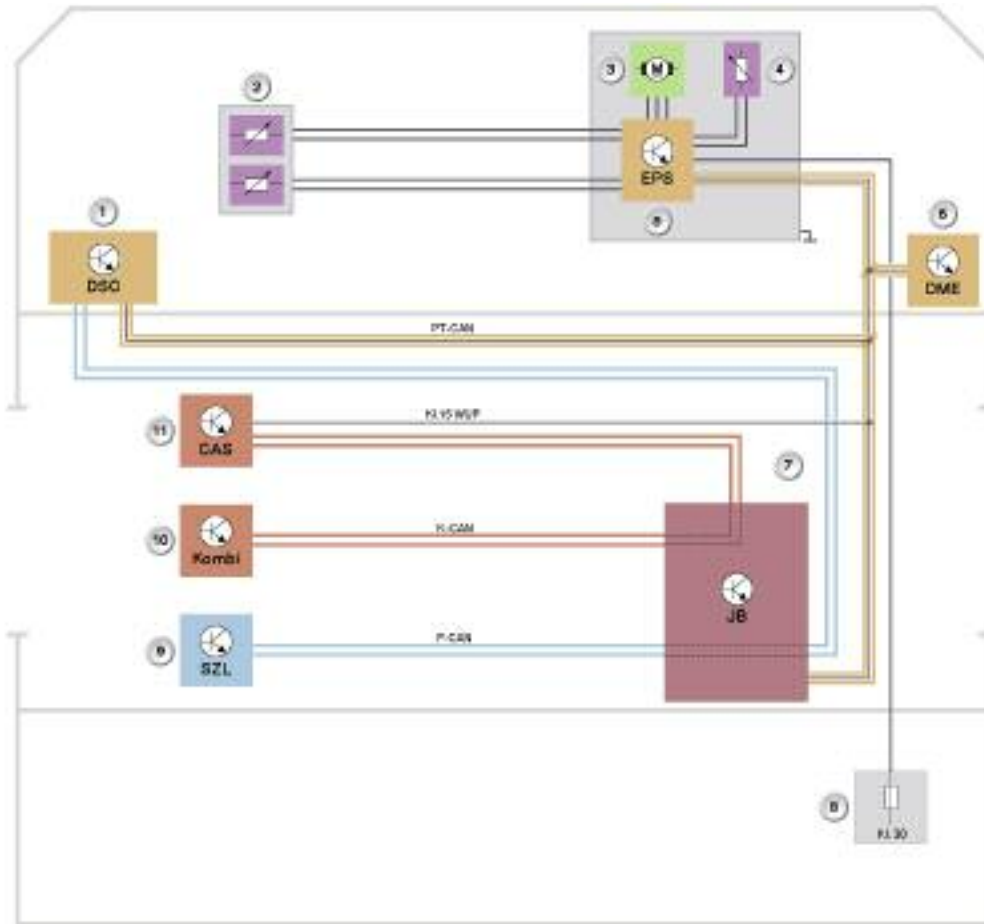

System Circuit Diagram for EPS on E8x

Index	Explanation
1	DSC control module
2	Steering torque sensor with redundant back-up
3	Electric motor
4	Motor position sensor
5	EPS control unit
6	DME control unit
7	Junction box
8	Fuse in boot (power supply for EPS)
9	Steering column switch cluster with steering-angle sensor
10	Instrument cluster
11	CAS control unit

System Components

The main components of the EPS system are the:

- Steering torque sensor
- EPS control unit
- Electric motor with position sensor
- Reduction gear
- Steering rack

Steering Torque Sensor

The steering torque sensor provides the EPS control unit with information about the steering torque applied by the driver in the form of an input signal. The EPS control unit uses that signal and other input signals to calculate the power assistance torque and operates the electric motor accordingly. The torque produced by the electric motor is added by way of the reduction gear to the steering torque applied by the driver. The total torque is converted by the steering rack into steering force at the front wheels.

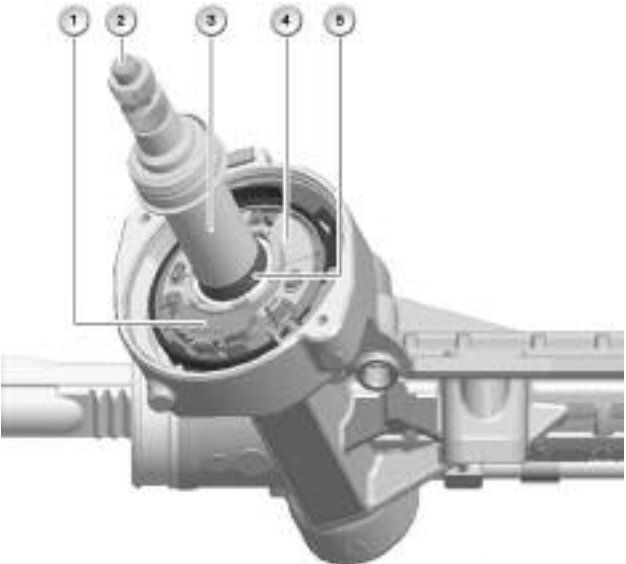

Index	Explanation
1	Sensor unit with analyzer circuitry
2	Torsion bar (top end) 5 Ring magnet
3	Input shaft
4	Coil spring
5	Ring magnet

Rotation of the input shaft (3) and ring magnet (5) is detected and electronically analysed by the sensor unit (1). The fundamental sensing principle applied is called the Hall effect.

As the rigidity of the torsion bar (2) inside the input shaft is known, the electronic circuitry can calculate the amount of torque applied from the degree of twist.

The steering torque is then digitally transmitted to the EPS control unit via a direct cable connection.

The sensor signal is provided with redundant back-up (a second identical sensor) so that system availability in the event of sensor failure is improved. If an unacceptable degree of divergence between the two sensors is detected during operation, the system continues to operate on the basis of the more plausible of the two signals and full EPS functionality is maintained.

If the fault status remains present at the end of the driving cycle, a fault memory entry is generated and the EPS does not operate when the next driving cycle starts.

EPS Control Unit

As well as the control circuitry, the EPS control unit also contains the power electronics for operating the electric motor.

The power electronics includes a multiple output relay that turns off the power supply to the motor windings in the event of a fault. Breaking the circuit allows the motor shaft to rotate freely. Fault conditions in which the motor would electrically lock up are avoided.

There is a temperature sensor integrated in the control unit that is required for detecting overload situations.

EPS Control Unit and Electric Motor Housing



Index	Explanation
1	Electric motor housing
2	Steering torque sensor lead connection
3	Bus connection
4	Cable to steering torque sensor
5	Power supply connection
6	Diaphragm made of Goretex
7	EPS control unit housing

The housing of the EPS control unit (and the electric motor) is located in a position exposed to large temperature fluctuations and high external moisture levels. Therefore, there is a diaphragm made of Goretex on the housing that equalizes the pressure difference between the inside and outside of the housing but still prevents moisture intrusion at that point

On the EPS control unit and electric motor housing there are also the following EPS electrical connections:

- Power supply for the EPS
- Bus connection (PT-CAN inc. wake-up line)
- Power supply and signal line for steering torque sensor

Electric Motor with Position Sensor

The essential function of the electric motor is to generate the required torque calculated by the EPS control unit.

The type of electric motor used is a brushless DC motor (made by Siemens).

Although it is powered by direct current, its method of operation is based on that of an AC synchronous motor. The power electronics in the EPS control unit convert the power supply voltage (DC voltage) into phase voltages so as to produce a rotating field at the phase windings.

Only this type of motor combines the following characteristics that are decisive for use in an EPS system:

- High efficiency
- Long service life
- Small external dimensions
- Low wear
- High thermal load capacity
- Constantly high torque over a wide speed range

The electric motor is almost exclusively operated in the speed range throughout which its torque is constant. Only in rare cases involving extremely high rates of steering angle change applied by the driver does the speed briefly reach the point at which the torque curve falls away with increasing motor speed. Very aware drivers may perceive this as reduction of power steering assistance. In contrast with hydraulic power steering, where the drop is noticeable as an abrupt stiffening, the change is progressive with EPS, which is generally perceived as more pleasant.

The maximum power consumption (transient) is 85 A so that at a rated voltage of 12 V a peak output of approximately 1 kW results. The fuse in the trunk that protects the power circuit against shorting has an appropriately high rating for that high current draw.

Available Torque Versus Rate of Change of Steering Angle (EPS vs. Hydraulic Power Steering)

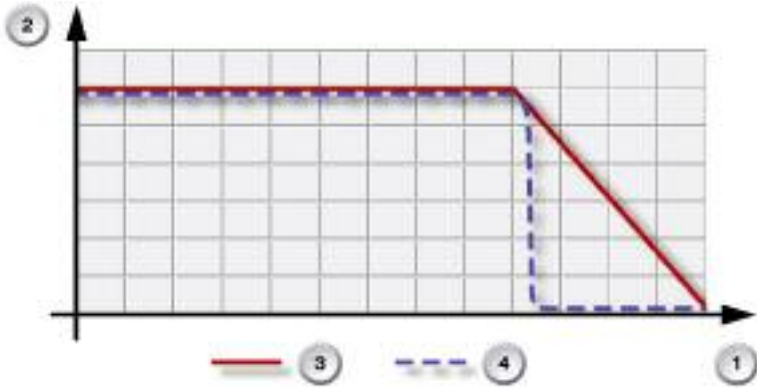

Index	Explanation
1	Speed of electric motor, equates to rate of change of steering angle
2	Torque
3	EPS electric motor - relationship of torque to motor speed
4	Hydraulic power steering pump - relationship of torque to steering angle rate of change

In contrast with the peak output, the average output required for delivery of EPS functions is very low. It is only between approx. 20 W and 40 W (depending on driving profile) because the electric motor is only supplied with power on demand, e.g. when cornering but not when travelling in a straight line (without having to use the steering).

Demand-based operation of the electric motor is the main reason why the fuel consumption of vehicles with EPS is around 0.2 l / 100 km less than that of vehicles with hydraulic power steering. And on the other hand, the power that would otherwise be required to constantly drive the power steering pump is now almost entirely available as additional motive power for the vehicle. Depending on the situation, there can be a linear dynamics gain of up to 2 kW.

A second important component is actually on the circuit board of the EPS control unit but is located directly adjacent to the electric motor shaft: the motor position sensor. In that way the motor position sensor can directly signal the electric motor's rotor position to the EPS control unit. As the electric motor is rigidly connected to the steering rack by means of the reduction gearing, the EPS control unit can deduce the position of the roadwheels and the steering angle from the rotor position.

After first calibrating the straight-ahead position with the aid of the signal from the steering angle sensor, the motor position sensor signal is subsequently used for the EPS functions (e.g. "active steering wheel return"). The reason for this is the higher resolution of the motor position sensor signal.

The sensing principle applied by the motor position sensor is identical with that used by the steering torque sensor. Both consist of Hall-effect sensor units adjacent to which there is a rotating magnet. The steering torque sensor is designed to detect small degrees of twist, while the motor position sensor must detect large amounts of rotation (a complete revolution must be measurable). The motor position sensor is also duplicated, though in this case the duplicate unit has a different resolution in order to be able to pick up both fast and slow movements effectively.

Reduction Gear

The reduction gearing transmits the torque generated by the electric motor to the steering rack, thereby applying steering force to the front wheels.

The overall transmission ratio is approximately 20 revolutions of the electric motor to one revolution of the steering wheel. That low gearing ratio combined with the high torque of the electric motor makes it possible to generate the required steering rack forces.

The low ratio combined with the rotating mass of the electric motor also has a damping effect on feedback from the road and roadwheels (as described in the section "Active damping").

The reduction gearing consists of the belt drive and reciprocating ball (screw) drive.

Reduction Gearing for EPS with APA

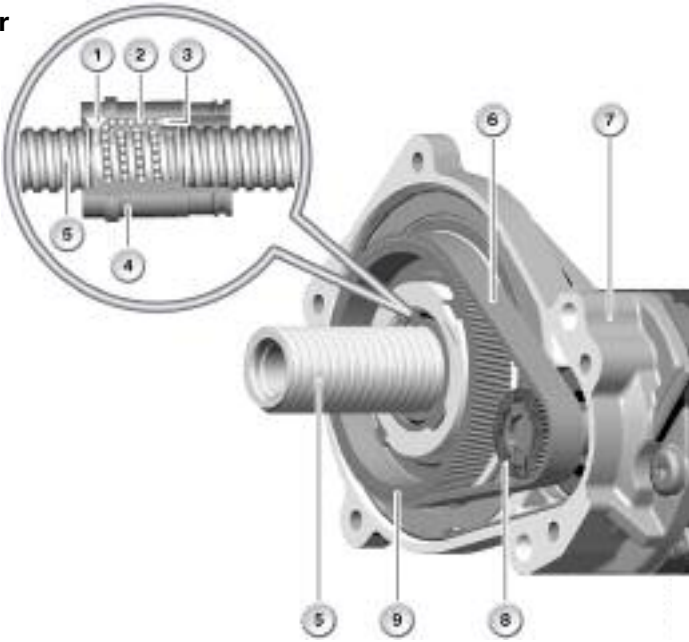

Index	Explanation	Index	Explanation
1	Ball bearing outfeed mechanism	6	Toothed drive belt
2	Ball bearing return channel	7	Reduction-gear housing
3	Ball bearing infeed mechanism	8	Small gear wheel
4	Nut of ball screw drive	9	Large gear wheel
5	Ball screw thread on steering rack		

The electric motor shaft drives the small gear wheel (8) of the belt drive directly. Via the toothed drive belt (6) and the large gear wheel (9), the nut (4) of the ball screw drive is made to rotate.

That nut contains a return channel (2) and mechanisms at either end of the bearing race for feeding the ball bearings into (3) and out of (1) the ball screw thread of the steering rack (5). Thus, the ball bearings circulate within a "closed system".

As the nut cannot move along the steering rack, the ball bearings moving along the ball screw thread exert an axial force on the steering rack.

The reduction gearing is inseparably attached to the electric motor. Repairs or adjustments to it as a separate component are not possible.

The reduction gearing and its components (including the drive belt) are designed to last for the life of the vehicle.

If the gaiter at the end of the steering rack is damaged, water can get into the reduction gear housing and therefore into the steering gear as well. That water will cause corrosion and, over time, loud noises when steering.

Nevertheless, power steering assistance from the EPS continues to be provided even in such cases.

In order that large amounts of water do not remain in the steering gear (e.g. after driving through deep water), a water drain valve has been fitted at the lowest point of the reduction gear.



If a defective bellows (boot) is discovered, it should be replaced so as to prevent water entering the steering gear. At the same time as replacing the gaiter, the water drain valve at the lowest point of the reduction gear should also be replaced and is included in the repair kit.

Steering Rack

The steering rack of the EPS system has the same function as that of a hydraulic power steering system.

It converts the steering force applied by the driver combined with the power steering assistance provided by the EPS into a force applied to the track rods. Ultimately, that results in steering movements by the front wheels.

The design and dimensions of the steering rack are such that the design of the other vehicle components only required marginal adjustments in order to enable the use of electric power steering.

In particular, the points of attachment to the wheels by way of the track rods and with the steering column are absolutely identical with those used up to now with the hydraulic power steering. The track rod also has the same gearing ratio.

Accordingly, the gearing ratio of the steering system as a whole is identical regardless of the power assistance method used.

As with hydraulic power steering systems, there is a thrust piece at the point where the pinion engages in the rack. It guides the rack and also serves as a means of adjusting the entire unit at the factory.

The thrust piece in this EPS system acts purely as a spring mechanism without a hydraulic bearing.



Adjustment of the steering rack and pinion using the thrust piece is a once-only operation carried out during production. That adjustment cannot and must not be performed at a dealership!

Principles of Operation

Overview of EPS Functions

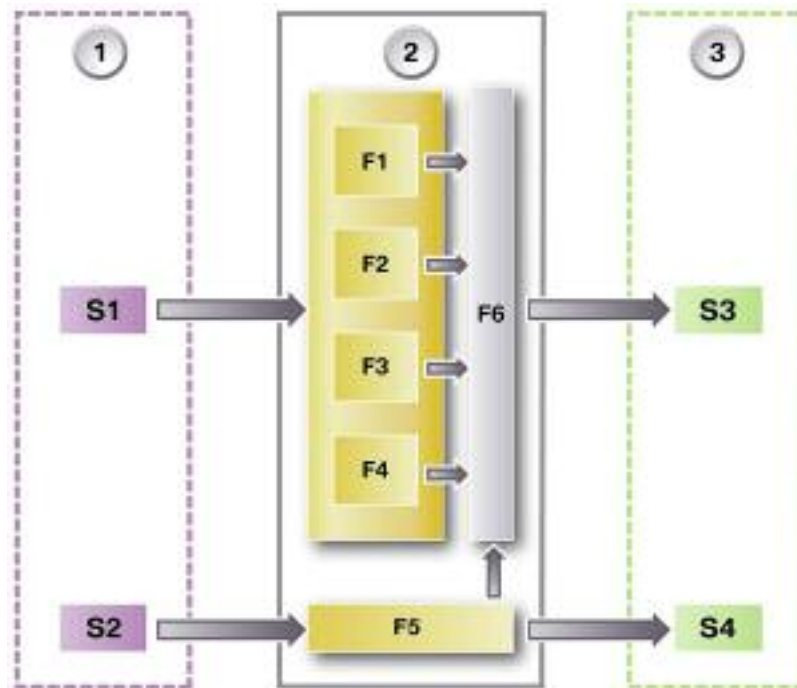

Index	Explanation
1	Input
2	EPS control unit
3	Output
S1	Input signals for EPS control and modulation functions <ul style="list-style-type: none"> - Steering force applied by driver - Road speed and other variables that describe the driving situation - Steering angle, steering angle rate of change
S2	Input signals for EPS status control <ul style="list-style-type: none"> - Terminal 15 on/off - Engine running/not running
F1	"Speed-dependent power steering assistance" function
F2	"Active steering wheel return" function
F3	"Active damping" function
F4	"Active roadwheel feedback" function
F5	"Status control" function
F6	"Coordination of specified settings" function
S3	Output signal of EPS control and modulation functions: control of electric motor
S4	Output signal of EPS status control: <ul style="list-style-type: none"> - Demand for higher cooling capacity - Control of warning and indicator lamps

EPS Input Variables

Steering Column Switch Cluster (SZL)	
Transmitter	Steering column switch cluster with steering-angle sensor
Signal	Steering angle set by driver
Transmitted via	PT-CAN
Receiver	EPS control unit
Function	Active steering wheel return

Dynamic Stability Control (DSC)	
Transmitter	Dynamic stability control with DSC sensor
Signal	Road speed and other variables that describe the driving situation
Transmitted via	PT-CAN
Receiver	EPS control unit
Function	Steering power assistance, active roadwheel feedback

Digital Motor Electronics (DME)	
Transmitter	Digital motor electronics
Signal	Engine running
Transmitted via	PT-CAN
Receiver	EPS control unit
Function	Status control

Car Access System (CAS)	
Transmitter	Car Access System
Signal	Terminal 15 status
Transmitted via	PT-CAN
Receiver	EPS control unit
Function	Status control

EPS Output Variables

Digital Motor Electronics (DME)	
Transmitter	EPS control unit
Signal	Demand for greater cooling capacity
Transmitted via	PT-CAN
Receiver	Digital motor electronics
Function	Control of electric fan

Instrument Cluster (Kombi)	
Transmitter	EPS control unit
Signal	Request for failure message
Transmitted via	PT-CAN
Receiver	Instrument cluster
Function	Control of warning and indicator lamps

Horizontal lines for notes.

NOTES

DME Functions Used by EPS

■ Intelligent Alternator Control

With the advent of "intelligent alternator control" (IGR) on the DME as an additional means of CO₂ reduction, the alternator voltage is adjusted according to the driving situation and battery charge level. Therefore, there will be periods in which the electrical system voltage is at the level that has been normal up to now (approximately 13.8 V). However, there will also be situations in which the voltage drops to around or just below 12 V.

The EPS components, and in particular the electric motor, are rated for a power supply of 12 V. At that level, the requirements in terms of maximum steering power assistance and speed are satisfied.

If the maximum EPS output were demanded at an alternator voltage of 12 V, the high current draw by the electric motor would produce a voltage drop on the EPS power supply line. The consequence would be an EPS input voltage of substantially below 12 V and, therefore, a reduced level of steering power assistance.

In order to prevent such an undesirable situation occurring, there is an additional IGR function for the EPS that is implemented without additional exchange of signals with the EPS and comprises the following features:

- Observation of whether an operating status exists in which high EPS output is required.
 - The bus signals indicating steering angle rate of change and road speed are monitored for that purpose. A high level of EPS output is identified when the steering angle rate of change is high at the same time as the road speed is low.
- Action: Increase of alternator output and temporary increase of electrical system voltage when high EPS output is detected.

This function ensures that the power supply at the EPS input terminals always provides at least the rated voltage of 12 V regardless, to a great extent, of other variables.



Detecting statuses involving high EPS output and raising the electrical system voltage constitute a control cycle that is completed within 2 seconds at most. As it is also an infrequent situation, it is unlikely that it will be the subject of customer complaints. If a particularly observant customer complains of momentarily reduced power steering assistance, this control cycle may possibly be the cause. If there are repeated complaints, performing a diagnosis on the power supply is advisable.

■ Speed-Dependent Power Steering Assistance

The Servotronic function that is only achievable by means of additional system complexity on hydraulic steering systems is implemented in the form of software on the electric power steering system and is therefore available with EPS.

The customer expects the lightest and smoothest steering movement possible when maneuvering or parking into spaces. Less sensitive steering setup is required when driving at high speed so that the vehicle can be kept on course more effectively.

Based on the sensor signals indicating the vehicle's road speed and the steering torque applied by the driver, the EPS provides a high level of power steering assistance at low speeds and when stationary (maximum convenience).

At high speeds on the other hand, the EPS demands greater steering force from the driver by reducing the level of power steering assistance. This helps the driver to hold a constant line.

As can be seen from the graph, the level of power assistance is computed on the basis not only of vehicle speed but also of the steering torque applied by the driver. If the driver applies a small amount of turning force to the steering wheel, the assistance from the EPS also initially remains at a relatively low level. This produces excellent self-centering characteristics, i.e. the steering does not react over-sensitively from the straight-ahead position.

If the driver applies greater force to the steering wheel, there is a smooth transition to a steeper curve gradient. As a result, the driver obtains the expected high degree of assistance when making abrupt steering movements or tight maneuvers.

The characteristics described here have been adopted by the EPS from the familiar hydraulic steering systems.

The transition between the curves is not abrupt but progressive. The EPS calculates appropriate transitional levels where necessary.

The steering characteristics of the EPS is influenced by the driver as in other vehicles by pressing the driving dynamics button.

EPS Speed-dependent Power Steering Assistance

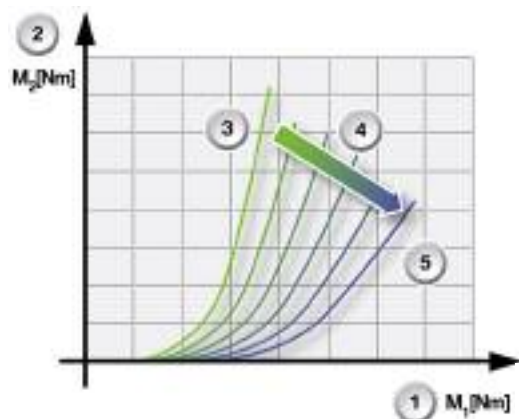

Index	Explanation
1	Steering torque applied by driver
2	Power assistance torque provided by EPS
3	Vehicle road speed equal to zero
4	Vehicle road speed increases
5	Vehicle road speed at maximum

■ Active Steering Wheel Return

In addition to the natural self-centering characteristics inherent in the steering and suspension systems, this function assists steering wheel return by appropriate operation of the electric motor.

The following signals are required for this purpose:

- Road speed
- Steering torque applied by driver
- Steering angle and
- Steering angle rate of change

However, the steering angle signal is only required for calibration with the electric-motor position sensor in order to determine the target position for steering wheel return (steering angle equal to zero). Thereafter, the active steering wheel return function uses the electric-motor position sensor signal as it has a higher resolution than the steering angle sensor signal and thus enables more precise control.

If the steering-angle sensor signal is not available, e.g. due to a fault on the SZL, the active steering wheel return function cannot operate. The other EPS functions remain active. Customers may possibly describe the resulting vehicle behavior as "pulling to one side" because the steering wheel does not return to the straight-ahead position as precisely as usual.

The necessity for activation of the active steering wheel return function arises when, for example, the driver allows the steering wheel to slip when exiting a corner. The signal values reflecting that situation which the EPS uses to detect the situation are:

- Steering angle clearly not equal to zero and
- Steering torque applied by driver approximately equal to zero

The electric motor is then operated by the EPS so as to generate a return force that produces smooth return of the steering wheel to a position close to the straight-ahead position.



If a customer complains of the car "pulling to one side" the possible causes to be considered include not only a mechanical problem with the suspension/steering but also a signal or communication fault between the EPS and the steering column switch cluster/steering-angle sensor. In such a situation, the EPS is unable to provide the active steering wheel return function and this may be perceived by the customer as the vehicle "pulling to one side".

Therefore, before checking the wheel alignment, the EPS fault memory should be checked and, if necessary, the stored testing sequence followed in order to make certain the signal from the steering-angle sensor is present.

The clearly perceptible improvement compared with the self-centering characteristics of hydraulic power steering systems is evident from the graph below.

The electric power steering returns to the center position more dynamically and precisely. This applies to all electric power steering systems used by BMW because they all incorporate the active steering wheel return function.

The self-centering characteristics of an EPS system without active steering wheel return shown on the graph are for comparison purposes only. They reveal themselves to be inferior to those of a hydraulic power steering system. This is due to the greater inertia of the electric motor and reduction gearing.

However, all EPS systems used by BMW incorporate active steering wheel return and therefore offer the benefits described above.

Self-centering Characteristics of Various Steering Systems

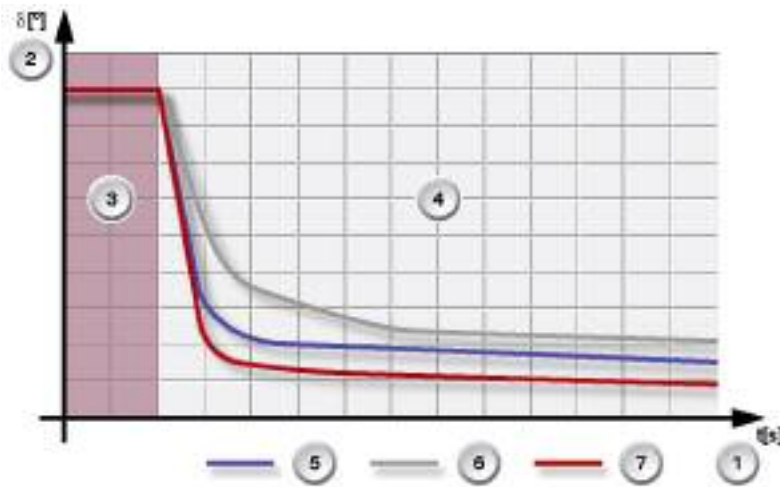

Index	Explanation
1	Time
2	Steering wheel angle
3	Driver holds steering at a constant lock (cornering)
4	Driver lets steering wheel slip (exiting corner)
5	Self-centering characteristics of a hydraulic power steering system
6	Theoretical self-centering characteristics of EPS without active steering wheel return
7	Self-centering characteristics of EPS with active steering wheel return

Active Damping

The undesirable steering wheel movements to be damped can be produced either by inadvertent steering input by the driver or feedback from the road/roadwheels.

■ **Damping Roadwheel Feedback**

The design of the front suspension (double link Macpherson strut suspension) on its own ensures that vertical wheel movements produce very little lateral force on the track rods.

Due to the low ratio of the reduction gear by which the electric motor is connected to the steering rack, the inertia of the electric motor also has a damping effect on the forces and movements transmitted from the roadwheels to the steering wheel. Those mechanical damping effects are supplemented by an electronic damping function on the part of the EPS. It analyses the movements of the steering rack (using the signals from the electric-motor position sensor) and operates the electric motor accordingly in response.

This means that feedback from external forces is transmitted in controlled amounts to the steering wheel so that, on the one hand, the driver obtains sufficient information about the nature of the road surface, but on the other, undesirably extreme steering wheel backlash is prevented.

■ **Damping Steering Input from Driver**

Particularly at high speeds, unintentional jerky movements of the steering wheel by the driver have a negative effect on vehicle handling stability. So-called "snatching" of the steering wheel can, under certain circumstances, cause the vehicle to start rocking, which can lead to snaking and the driver ultimately losing control of the vehicle if corrective action is not taken quickly enough.

The EPS detects such steering input and operates the electric motor so as to substantially damp the movements, particularly at high speeds. As a result, vehicle rocking is prevented.

Damping of Steering Input by EPS

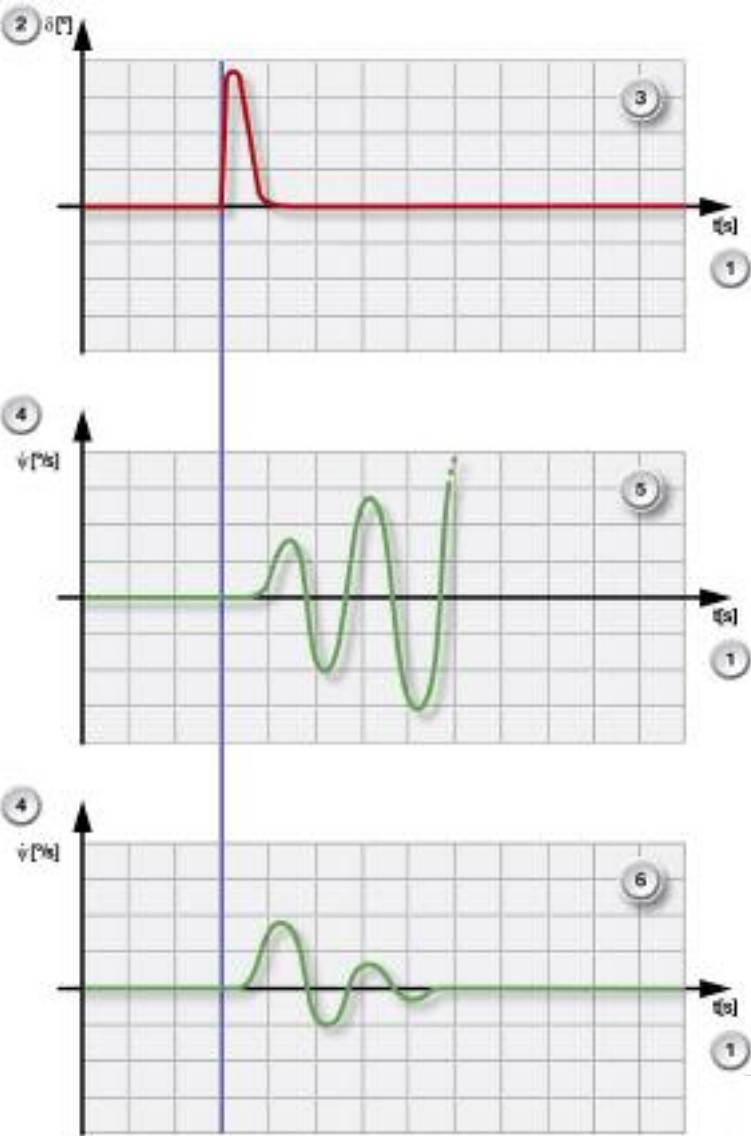

Index	Explanation
1	Time
2	Steering wheel angle
3	Steering angle progression (steering input by driver, "snatching" the steering wheel)
4	Yaw rate
5	Theoretical vehicle response without active damping: the turning action following the steering input is progressively amplified at high vehicle speed.
6	Desirable vehicle response with active damping: the turning action is heavily damped even at high vehicle speeds.

Active Roadwheel Feedback

Partly due to the damping effect of the inertia of the electric motor, an EPS system can inherently not provide as direct feedback about the nature of the road surface as a hydraulic power steering system.

In order to obtain virtually identical roadwheel feedback characteristics on vehicles with EPS, the EPS analyses information that describes the vehicle's dynamic handling situation. From that information, the EPS computes additional "EPS road surface data". As a result, the driver obtains better roadwheel feedback characteristics which are very similar to those of a hydraulic power steering system.

Control

The EPS status control function makes the overriding decision as to whether operation of the electric motor is permissible or not. It produces a clearance signal that is sent to the EPS function that is co-ordinating the subordinate specified settings of the control and modulation functions.

The conditions for allowing operation are the following:

- Ignition must be switched on
- Engine must be running
- There must be no EPS input signal faults or EPS internal faults present

The response to detected faults described below represents an exception.

■ Status Shutdown in the Event of Faults

A primary aim in the development of the EPS was to ensure that vehicle response in the event of faults would remain manageable by the driver. Therefore, under no circumstances must a sudden high steering force in either direction be allowed to occur. For that reason, the EPS has numerous monitoring functions for detecting faults on the sensors, actuators and associated systems that are involved in EPS operation.

All fault statuses in which reliable and correct control of the electric motor is not possible result in the disabling of motor operation and, therefore, shutdown of the EPS functions.

The consequence of that is that the driver no longer benefits from the convenience of power-assisted steering. More importantly, however, incorrect control of the electric motor is prevented.



The loss of power steering assistance in the event of faults constitutes an intended system response on the part of the EPS.

Although such a response may be slightly unnerving for the driver, the vehicle remains fully steerable with greater physical effort.

Loss of power steering assistance in the event of faults occurs both with electric and hydraulic power steering. The two systems thus also behave in a similar manner in response to faults.

In such a fault situation, a yellow warning lamp lights up on the instrument cluster. The driver is also notified of the fact that power steering assistance from the EPS is no longer available by display of the appropriate Check Control symbol together with the explanatory message on the Central Information Display.

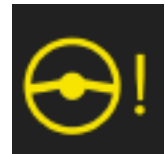

Coordination of Specified Settings

The specified settings for the control and modulation functions for operating the electric motor are co-ordinated at a central point by the EPS software. If a clearance signal from the status control function is present, the individual specified settings are normally added together and signalled as a total value.

In certain transitional situations the specified settings are filtered before they are signalled.

The following are examples of such cases:

- The EPS goes into operation after the engine is started. The power assistance torque is increased progressively until the desired level is reached.
- The EPS reduces the power steering assistance for function-related reasons (see also the section "Supplementary functions").

In the event of a fault the control signal for the electric motor is abruptly cancelled instead of being filtered in order to prevent incorrect operation as quickly as possible.

Supplementary Functions

The functions described below are encountered only rarely in special operating situations. The information given here can help to distinguish those special operating statuses, which do not require repairs, from genuine faults when handling complaints from customers.

■ Protection Against Overload

The EPS reduces the degree of power steering assistance if the temperature of EPS components becomes too high. By limiting motor operation, the amount of heat generated by the EPS itself is also limited, thereby protecting the components against excessive thermal stress.

This action starts to come into effect from a temperature of approximately 100°C and escalates to the point where power steering assistance is reduced to zero at a temperature of 115°C.

Upwards of a certain degree of function restriction, the warning light on the instrument cluster is switched on (see the section "Shutdown in the event of faults") and a fault registered in the fault memory.

In addition to reducing power steering assistance, the EPS also requests higher electric fan output from the DME in order to produce a greater cooling effect.

This type of overload can occur at high ambient temperatures combined with simultaneous high degrees of steering activity, especially when stationary.

Another overload situation can occur if an attempt is made to turn the front wheels against a solid obstacle (e.g. a kerbstone). If this situation occurs repeatedly at short intervals, the degree of power steering assistance is similarly reduced. This firstly protects the EPS components against excessive mechanical stresses, and secondly signals to the driver that there is a solid object preventing the wheels turning.

Service Information

Replacing an EPS System

The EPS components consisting of steering torque sensor, EPS control module unit, electric motor with position sensor, reduction gear and steering rack form a single unit (often referred to as "EPS steering rack assembly") that can only be replaced as a complete unit. To do so, the unit has to be disconnected from the track rods and the lower end of the steering column.

After a new EPS steering rack is fitted, a front wheel and tracking alignment check is required. The commissioning sequence involves coding the EPS to match the vehicle model and the diagnosis function for learning the end-stop positions.

Intelligent Alternator Control and EPS

Detecting statuses involving high EPS output and raising the electrical system voltage constitute a control cycle that is completed within 2 seconds at most. As it is also an infrequent situation, it is unlikely that it will be the subject of customer complaints.

If a particularly observant customer complains of momentarily reduced power steering assistance, this control cycle may possibly be the cause. If there are repeated complaints, performing a diagnosis on the power supply is advisable.

Active Steering Wheel Reset

If a customer complains of the car "pulling to one side" the possible causes to be considered include not only a mechanical problem with the suspension/steering but also a signal or communication fault between the EPS and the steering column switch cluster/steering-angle sensor. In such a situation, the EPS is unable to provide the active steering wheel return function and this may be perceived by the customer as the vehicle "pulling to one side".

Therefore, before checking the wheel alignment, the EPS fault memory should be checked and, if necessary, the stored testing sequence followed in order to make certain the signal from the steering-angle sensor is present.

Protection Against Overload

The EPS reduces the power steering assistance in overload situations. If customer complaints are received, the customer should be questioned as to the situation in which the symptoms occurred before commencing any repair work.

If necessary enlighten the customer as to the way in which these protective functions operate.

EPS System (FXx)

A vehicle's steering plays a central role in the chassis and suspension. The technological innovations introduced by BMW like active steering and rear axle slip angle control are constantly being enhanced and further developed for use in our vehicles.

Starting with the launch of the BMW 5 Series (F10) the implementation of a completely electrical steering system with the use of EPS (Electronic Power Steering).

This system is a modified and enhanced version of the E89 Z4 EPS system previously described.

A version of the F10 introduced EPS is currently installed in most BMW models.

F10 EPS and IAL Components

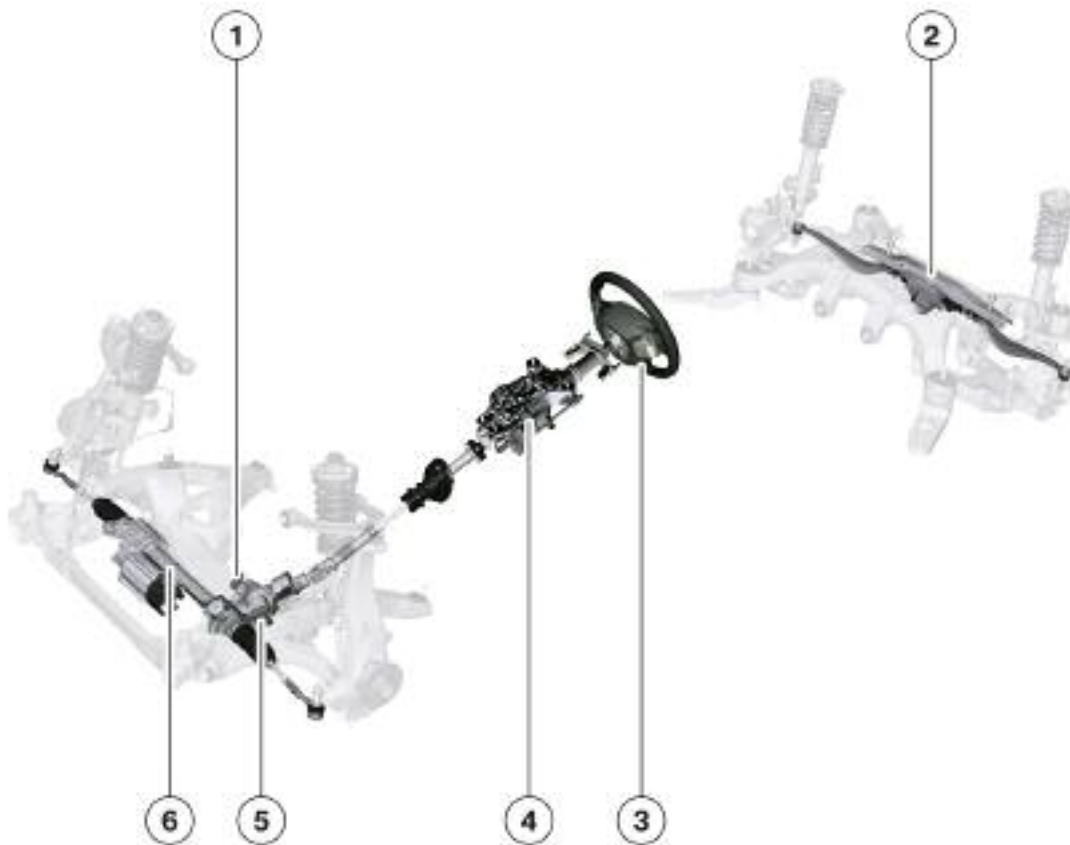

Index	Explanation
1	Active steering lock
2	HSR actuator
3	Steering wheel
4	Steering column
5	Active steering servomotor with motor position angle sensor
6	Electromechanical power steering

Index	Explanation
1	EPS
2	Digital Motor Electronics (DME)
3	Junction box electronics with front power distribution box
4	Integrated Chassis Management (ICM)
5	Intelligent battery sensor (IBS)
6	Battery
7	Battery power distribution box
8	Steering column switch cluster (SZL)
9	Instrument cluster (KOMBI)
10	Central Gateway Module (ZGM)

System Overview

The EPS enables average fuel consumption to be reduced by approx. 0.3 l/100 km (0.317 quart/62 miles) compared to a conventional hydraulic steering system. This contributes to a reduction of CO2 emissions.

F10 EPS without Active Steering

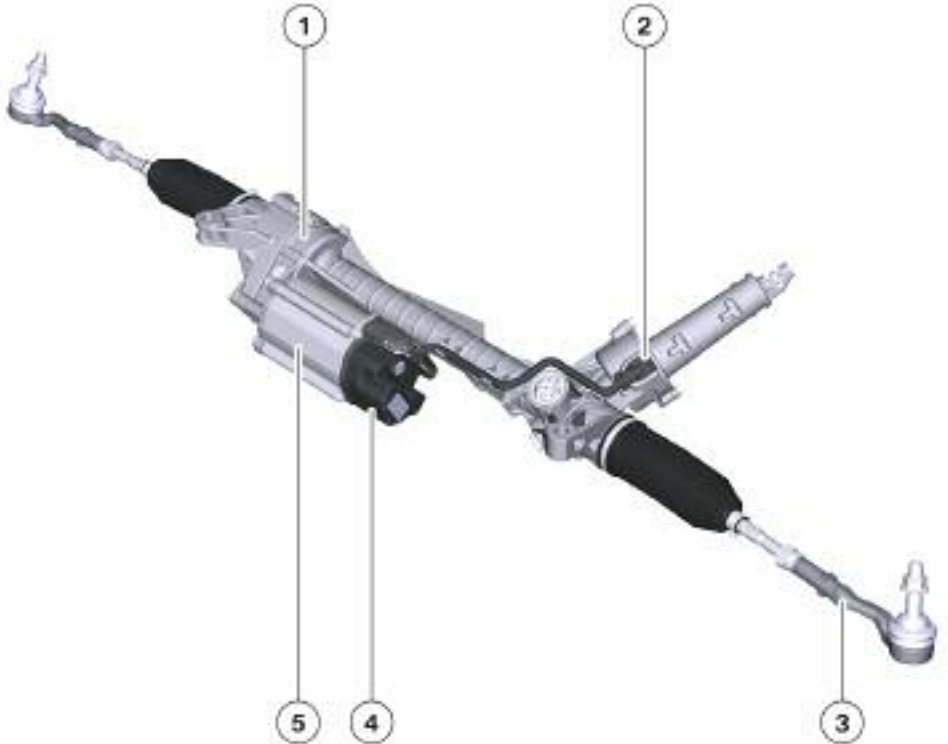

Index	Explanation
1	Speed reducer
2	Steering-torque sensor
3	Track rod
4	EPS control unit
5	Electric motor with motor position sensor

The EPS steering replaces the conventional hydraulic steering system. EPS is always equipped with the Servotronic function. Using the drive dynamic control switch, two different adjustments can be achieved: "Normal" and "Sporty".

The EPS is less sensitive to disturbance variables such as bumps and steering wheel vibration. It also contributes to the driving safety with an active roll damping.

Because there is no oil in the EPS, it is more environmentally friendly than conventional hydraulic steering systems.

The EPS has Active return to center, this delivers optimum drivability. The EPS also makes it possible for the parking assistance to be implemented for the first time in a BMW vehicle.

For more information about parking assistance, refer to the "F10 Driver Assistance Systems" section in this training material.

Integral Active Steering

Introduced with the F01, the (optional) Integral Active Steering (IAL) is made up of two individual systems (the rear axle slip angle control (HSR) and the active steering (AL) on the front axle) which cannot be ordered separately.

The EPS (introduced on the F10) was especially adapted and modified to work with the active steering on the front axle.

Originally (with the launch of the F10) the use of heavier 8 cylinder engines combined with the optional IAL required the installation of the 24V EPS due to the extra drag on the steering. Later advances and upgrades to the basic system now make it possible to use to the basic 12V EPS in these cases.

However, regardless of their powertrain, most current BMW vehicles with the Integral Active Steering option still require the use of the 24V EPS system due to the extra drag on the steering.



Currently all BMW models equipped with xDrive are fitted with hydraulic steering.



See the Integral Active Steering section in this training manual for more information.

F10 System Wiring Diagram for Integral Active Steering w/EPS

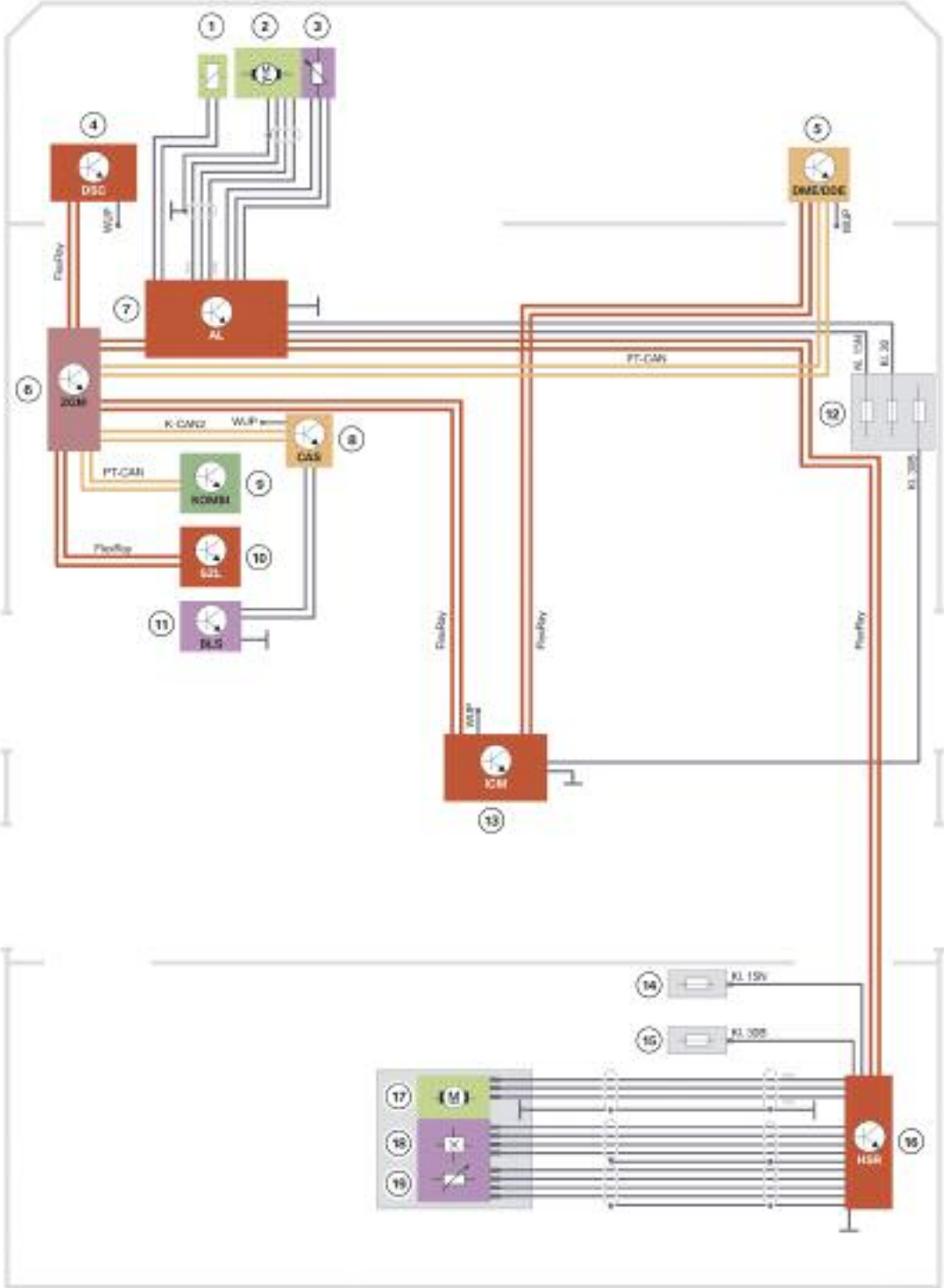

Index	Explanation
1	Active Steering lock
2	Active Steering electric servomotor
3	Active Steering motor angular position sensor
4	Dynamic Stability Control (DSC)
5	Digital Motor Electronics (DME)
6	Central Gateway Module (ZGM)
7	Control unit for Active Steering
8	Car Access System (CAS)
9	Instrument cluster (KOMBI)
10	Steering column switch cluster (SZL)
11	Brake light switch (BLS)
12	Front power distribution box
13	Integrated Chassis Management (ICM)
14	Rear right power distribution box
15	Battery power distribution box
16	Control unit for rear axle slip angle control (HSR)
17	HSR actuator
18	Hall-effect sensor
19	Track-rod position sensor

Active Steering

With the optional equipment integral active steering, the steering gear is expanded by adding a planetary gearbox with override function, which implements a speed-dependent steering gear ratio that was already introduced with the E60.

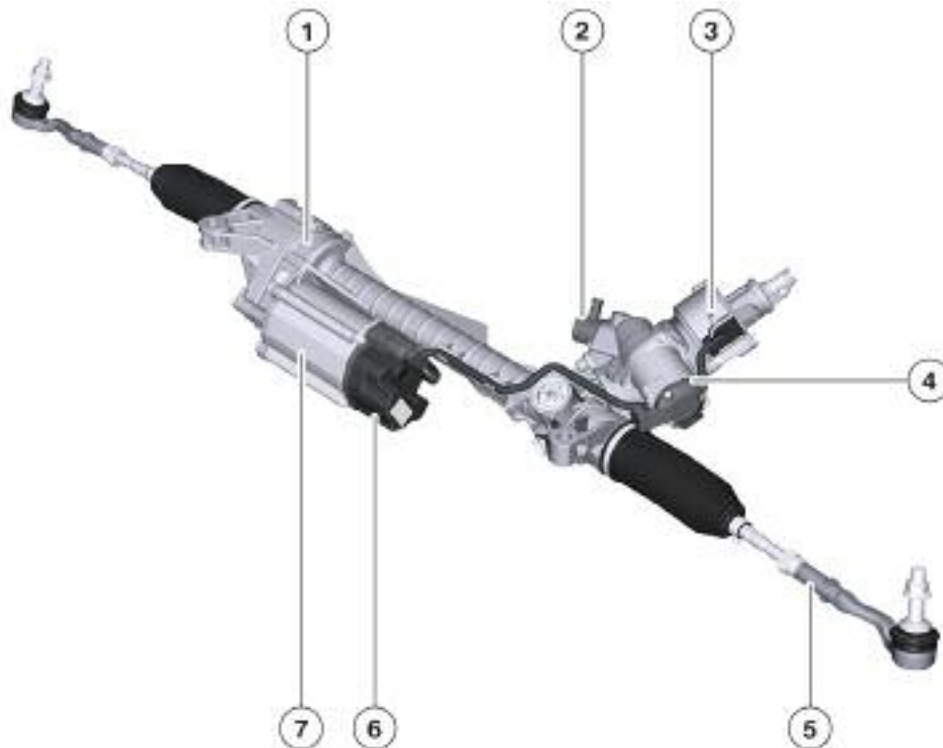

F10 EPS with Active Steering

Index	Explanation
1	Speed reducer
2	Active steering lock
3	Steering-torque sensor
4	Active steering servomotor with motor position angle sensor
5	Track rod
6	EPS control unit
7	Electric motor with motor position sensor

EPS with 12V

Because active steering demands higher forces from the electromechanical steering and to comply with the higher current draw, when active steering is used in a vehicle with 12V EPS, the voltage is supplied by a separate positive battery connection point.

F10 System Wiring Diagram EPS with 12V and Active Steering

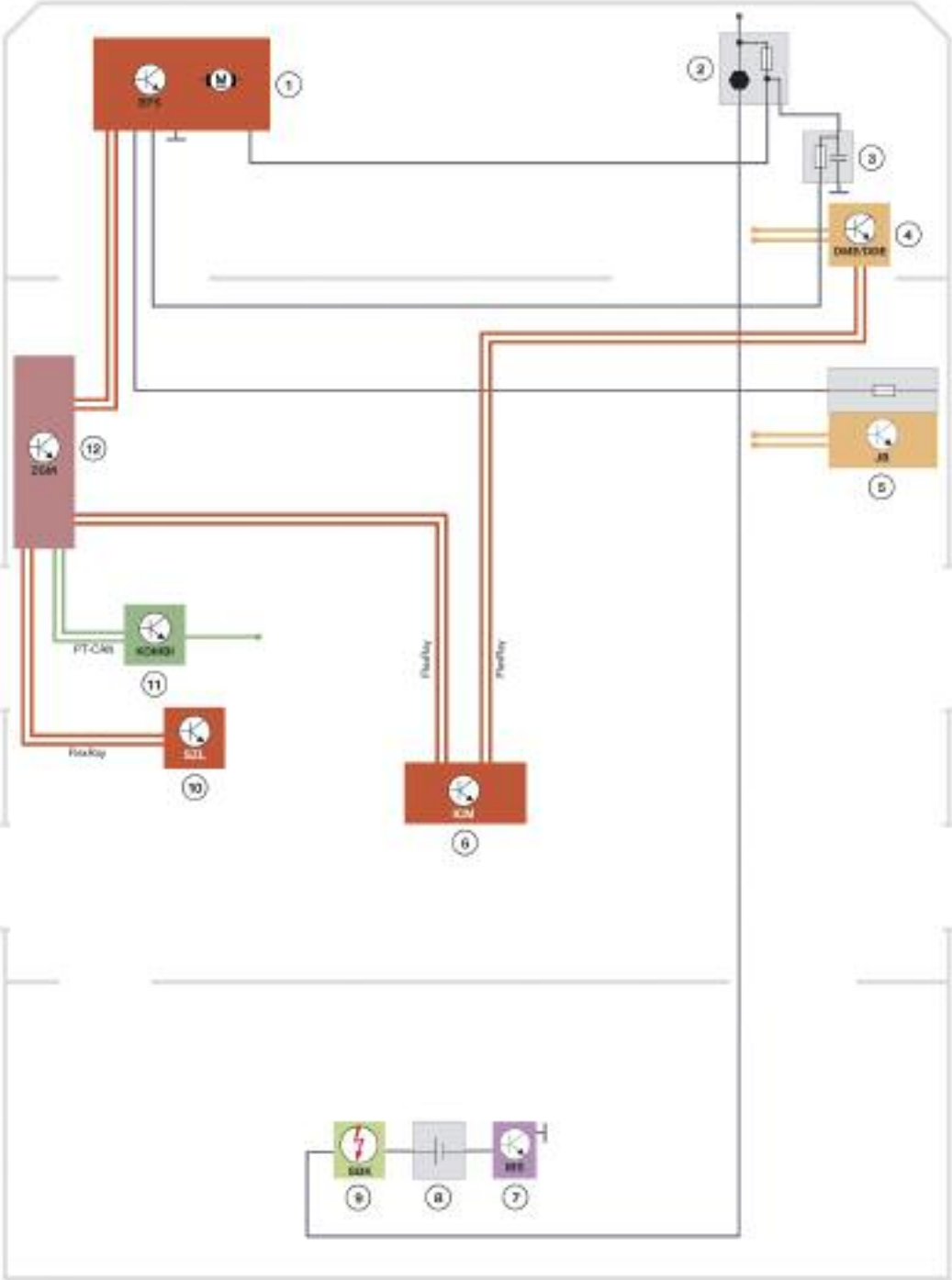

Index	Explanation
1	EPS
2	Positive battery connection point
3	Capacitor box
4	Digital Motor Electronics (DME)
5	Junction box electronics with front power distribution box
6	Integrated Chassis Management
7	Intelligent battery sensor (IBS)
8	Battery
9	safety battery terminal (SBK)
10	Steering column switch cluster
11	Instrument cluster (KOMBI)
12	Central Gateway Module (ZGM)

EPS with 24V

The higher front axle load causes the power required for the steering servo to increase. In conjunction with the integral active steering, an even higher exertion of force is applied, and therefore even higher current is required for the steering servo.

This high current made it necessary to increase the voltage supply of the EPS to 24V.

This requires an auxiliary battery, a separator and a charging unit for the auxiliary battery. These components are installed in the luggage compartment.

24V EPS System Components

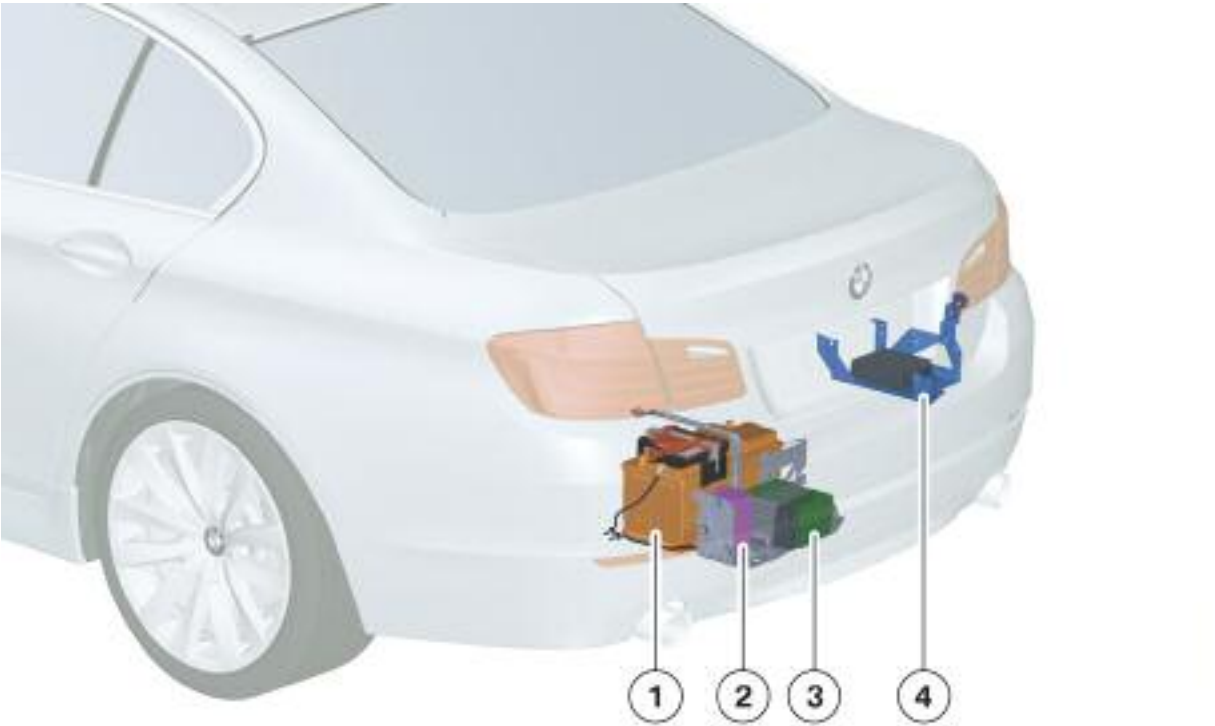

F10 550i 24V EPS Components

Index	Explanation
1	Battery
2	Separator
3	Auxiliary battery
4	Battery charging unit for auxiliary battery (BCU)

The following system wiring diagram shows the integration of the new components into the vehicle electrical system.

24V EPS and Active Steering Wiring Diagram

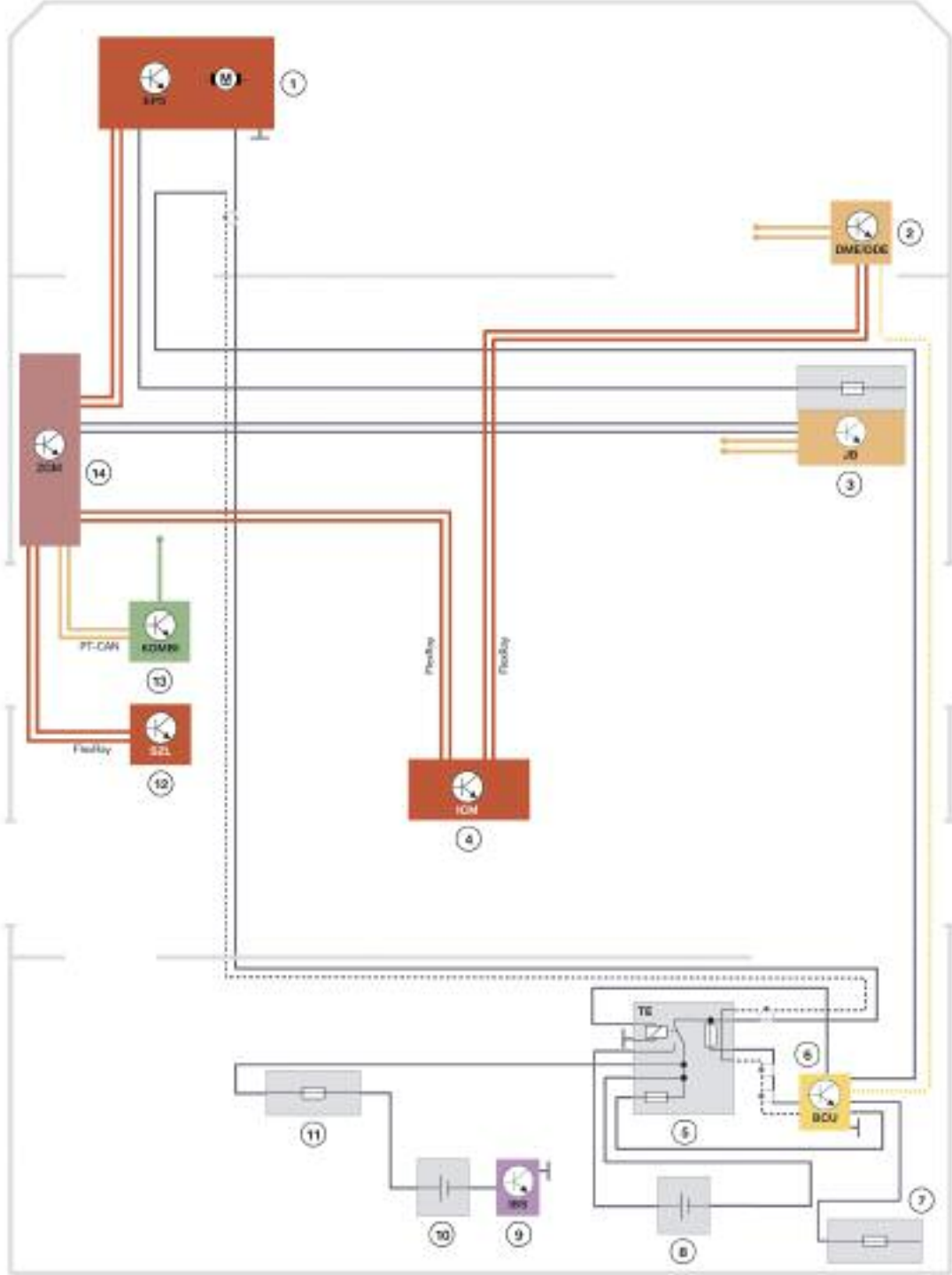

F10 System Wiring Diagram EPS with 24V and Active Steering

Index	Explanation
1	EPS
2	Digital Motor Electronics (DME)
3	Junction box electronics with front power distribution box
4	Integrated Chassis Management (ICM)
5	Separator
6	Battery charging unit for auxiliary battery (BCU)
7	Rear right power distribution box
8	Auxiliary battery
9	Intelligent battery sensor (IBS)
10	Battery
11	Battery power distribution box
12	Steering column switch cluster (SZL)
13	Instrument cluster (KOMBI)
14	Central Gateway Module (ZGM)

The BCU (charging unit) takes over the monitoring of the state of charge and the charging of the auxiliary battery with a 150W DC/DC converter. It monitors a cable (isolation) sheathing of the 24V line and it switches the relay in the separator with which the auxiliary battery is integrated into the circuit. The EPS is supplied with 24V only after this relay has been switched on. In the event of a fault, the EPS can also be operated with 12V. If there is no fault, the relay in the separator is switched as of terminal 15.

The 24V line is routed on the vehicle floor and is surrounded by a cable sheath which is monitored by the charging unit (BCU). The following system wiring diagram details the various switch situations and the charging of the auxiliary battery.

F10 24V Operation of the EPS

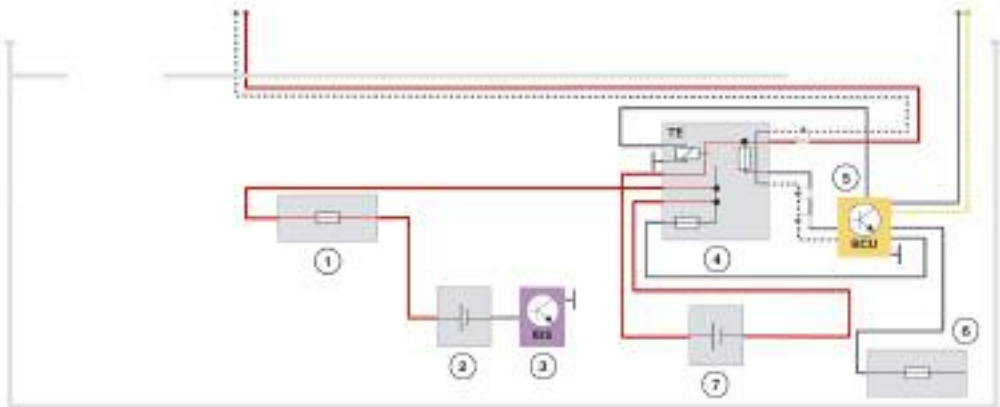

Index	Explanation
1	Battery power distribution box
2	Battery
3	Intelligent battery sensor IBS
4	Separator (here: 24V operation)
5	Charging unit for auxiliary battery (Battery Charge Unit BCU)
6	Rear right power distribution box
7	Auxiliary battery

In 24V operation mode, the battery and the auxiliary battery are connected in series by the relay in the separator. As a result, the EPS is operated with 24V.

F10 12V Operation in the Event of a Fault

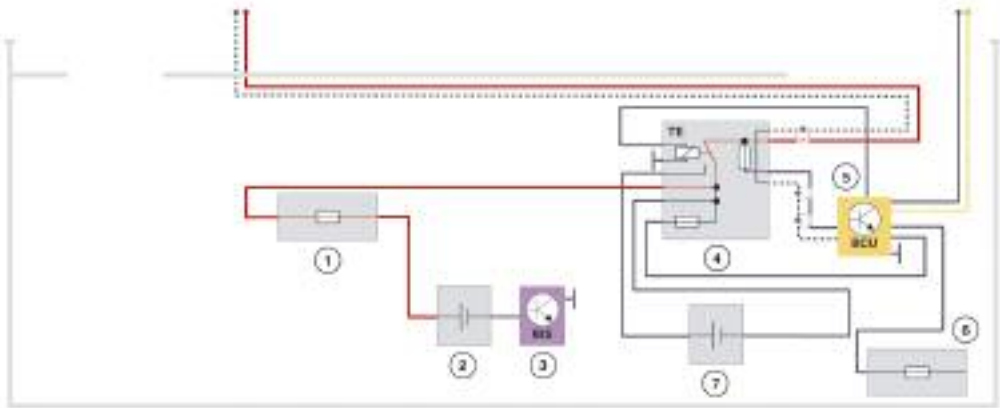

Index	Explanation
1	Battery power distribution box
2	Battery
3	Intelligent battery sensor IBS
4	Separator (here: 12V operation)
5	Charging unit for auxiliary battery (Battery Charge Unit BCU)
6	Rear right power distribution box
7	Auxiliary battery

In the event of a fault or before terminal 15, the relay is open and the separator is in the 12V position. The auxiliary battery is no longer connected in series and is no longer in the circuit.

F10 Charging of the Auxiliary Battery in 24V Operation

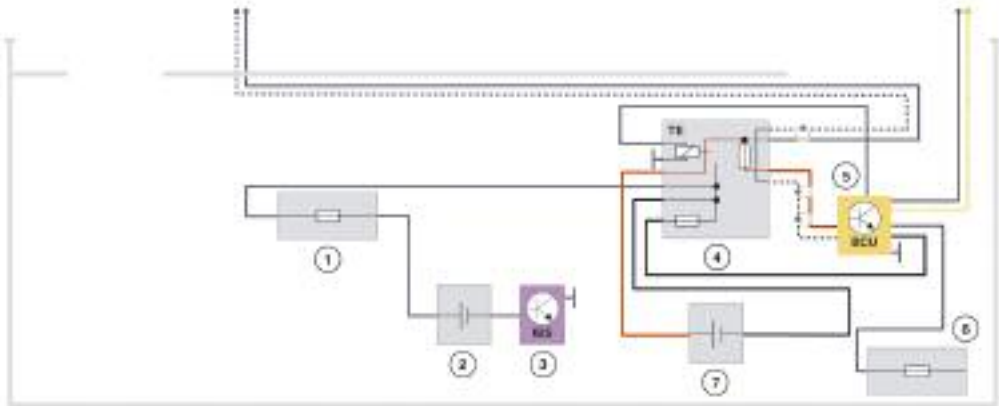

Index	Explanation
1	Battery power distribution box
2	Battery
3	Intelligent battery sensor IBS
4	Separator (here: 24V operation)
5	Charging unit for auxiliary battery (Battery Charge Unit BCU)
6	Rear right power distribution box
7	Auxiliary battery

The auxiliary battery can be charged in 24V operation using the battery charging unit for the auxiliary battery. To do so, the charging unit takes the energy it uses for charging the auxiliary battery from the vehicle electrical system via the rear right power distribution box.

F10 24V Components and Line Routing



Index	Explanation
1	Battery charging unit for auxiliary battery (BCU)
2	Separator and auxiliary battery
3	Battery
4	EPS with active steering

Variable Sport Steering

The optional equipment "Variable sport steering" (SA 2VL) is currently available for the F25 as an alternative to the basic version of the EPS. This is the first steering system available on the market to combine the benefits of an extremely direct, variable steering gear ratio with the operating principle of EPS steering.

Variable sport steering increases ride comfort and agility while the direct ratio reduces the total steering angle (i.e. the number of steering wheel revolutions from steering stop to steering stop) by roughly 25%. This therefore increases comfort during driving manoeuvres that require larger steering angles, e.g. when parking.

Compared to the basic version of the EPS steering, the vehicle responds more directly and has greater agility due to the more direct steering gear ratio and the resulting lower required steering angle. This is effective during avoidance manoeuvres, for example.

Comparison of Steering Angle Ratio

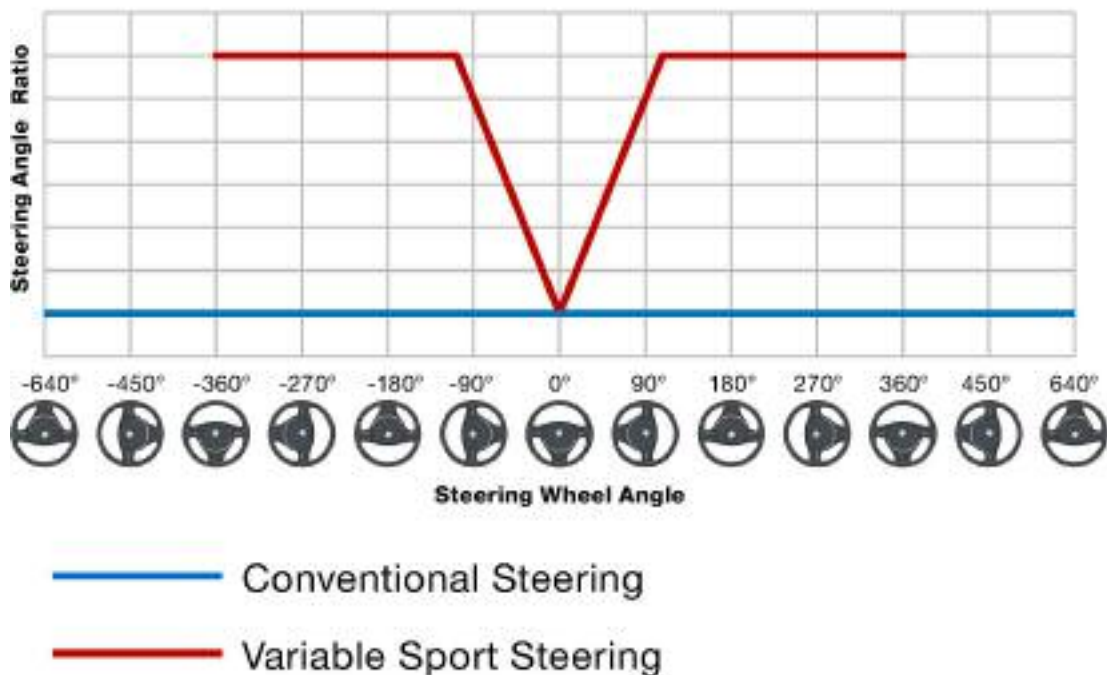

The variable steering gear ratio is achieved by using a displacement-dependent rack gearing geometry.

When roughly in the center position of the steering box, the steering responds precisely with stable directional stability. As the steering angles move out of the center position, the ratio becomes increasingly more direct.

F25 Comparison Between Steering Gear Ratio of EPS Steering Basic Version and Variable Sport Steering

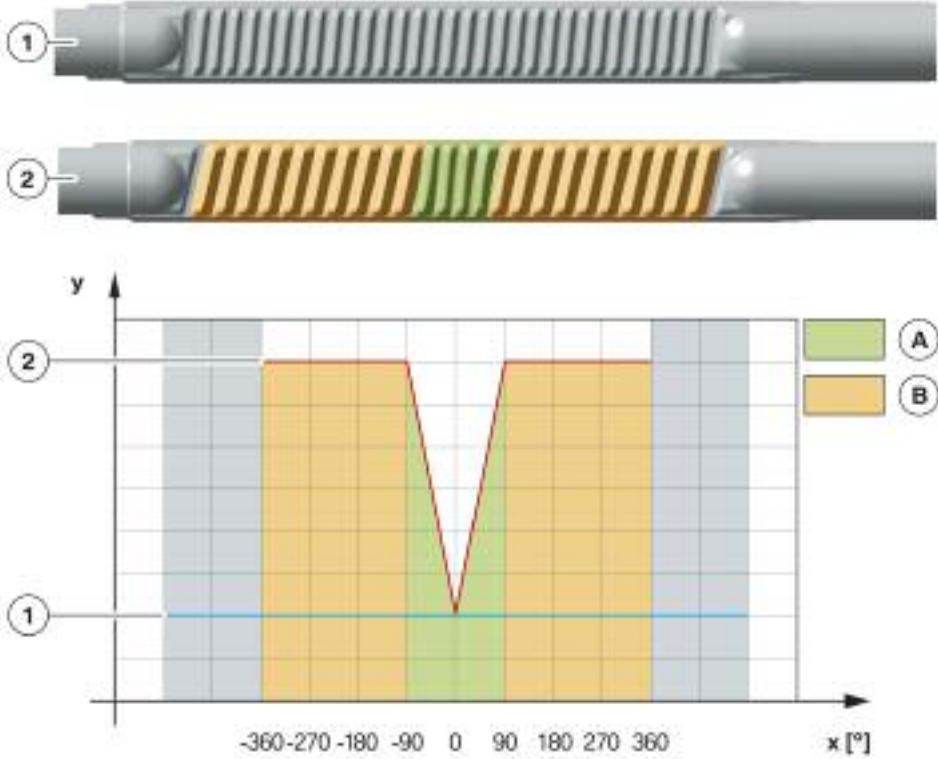

Index	Explanation
1	Rack, EPS basic version (constant gearing geometry)
2	Rack, variable sport steering (variable gearing geometry)
A	More indirect steering gear ratio (variable sport steering)
B	More direct steering gear ratio (variable sport steering)
x	Steering angle
y	Steering gear ratio

F25 Variable Sport Steering Rack Components

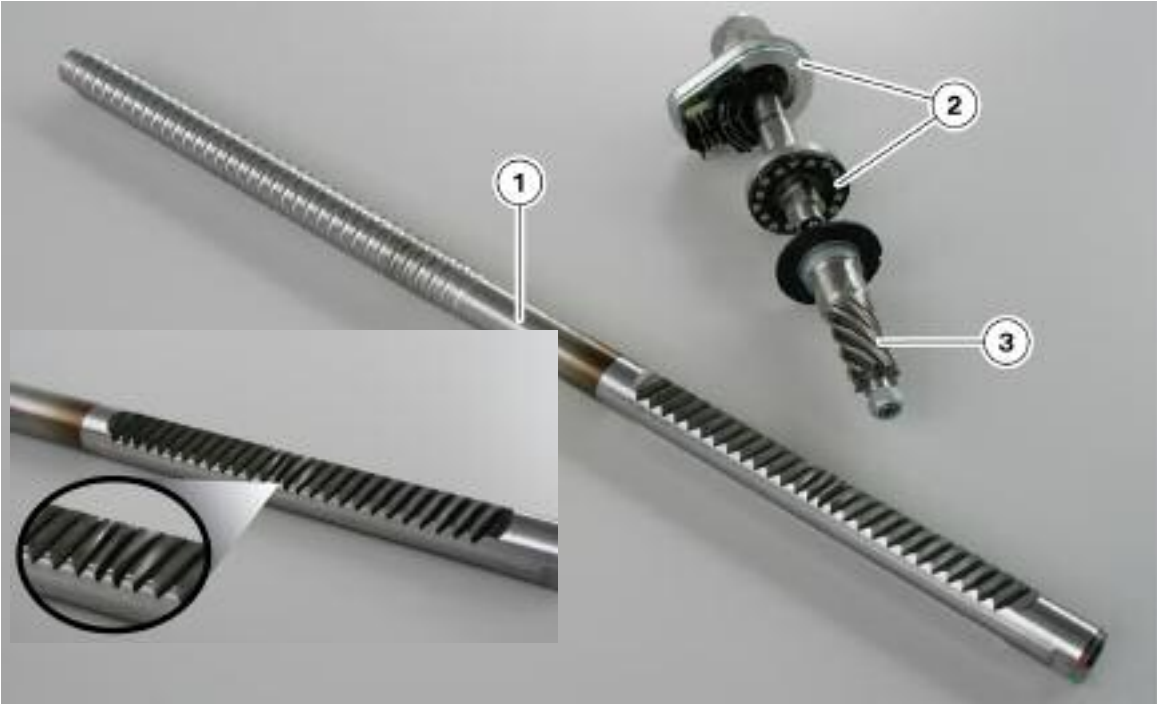

Index	Explanation	Index	Explanation
1	worm gear	3	pinion gear
2	Steering torque sensor		

F25 Steering Angle Sensor

In the F25, information on the steering angle is not acquired via the Electronic Power Steering (EPS) from a separate sensor at the steering wheel and is instead deduced from the motor position angle of the EPS motor in relation to the steering wheel.

The EPS reports the position of the rack via FlexRay to the ICM control unit. In this case the EPS calculates the absolute position of the rack based on the current position of the EPS motor rotor and the number of full rotor revolutions from the neutral position (corresponds to straight-ahead driving).

Taking this position as the starting point, the ICM control unit determines, among other things, the steering angle in relation to the wheel using the stored gear ratio parameters (between the rack and steering angle in relation to wheel) and transmits these via FlexRay. This wheel-specific steering angle is used by the Dynamic Stability Control and other systems as a reference variable for internal control functions.

In cases where the absolute value is not available from the EPS (terminal 30 loss, flashing process), the absolute value is determined through interaction of the ICM and EPS via a teach-in function by steering from end stop to end stop (e.g. straight-ahead position -> left -> right -> straight-ahead position).

F25 EPS Wiring Diagram

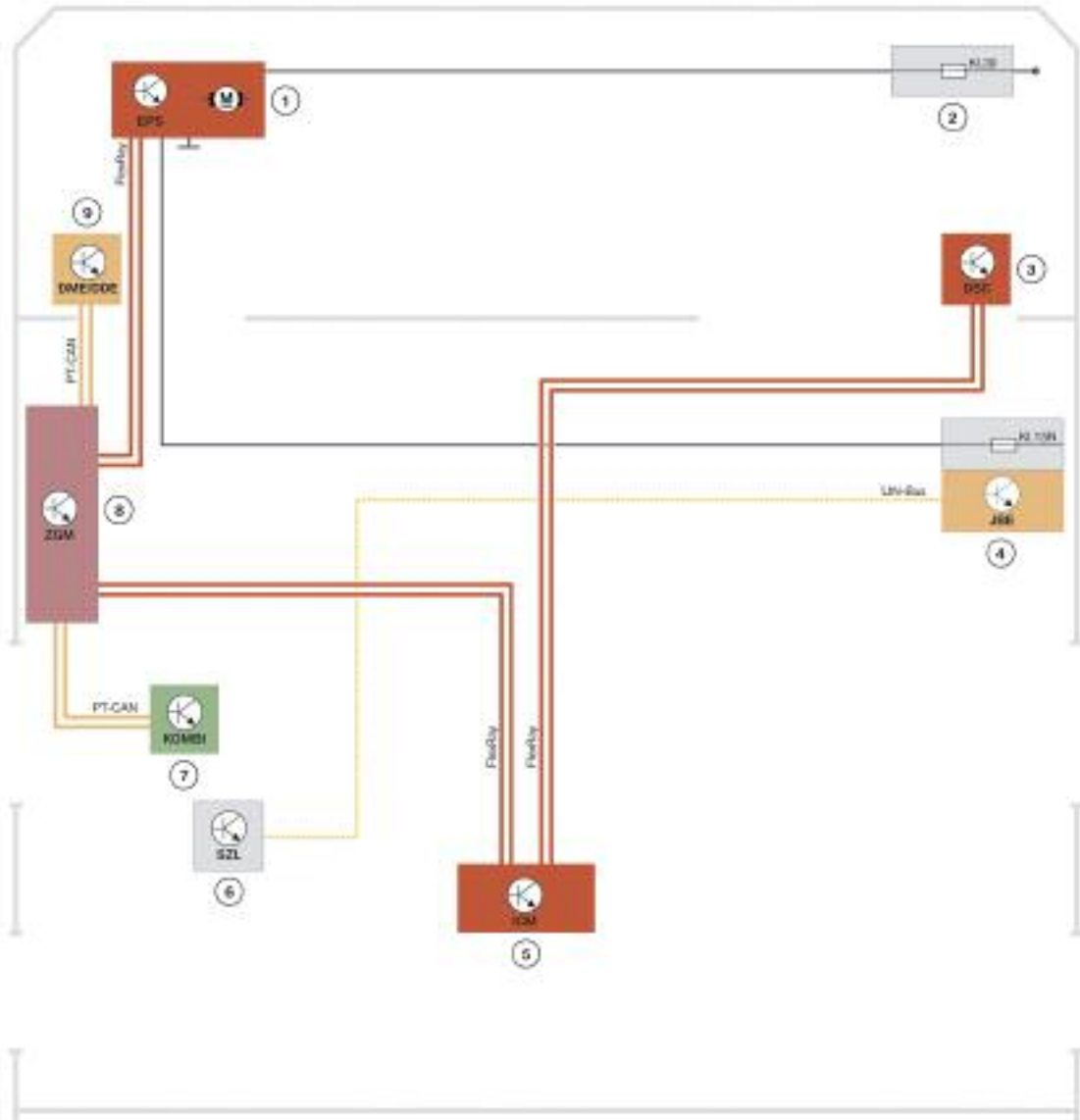

Index	Explanation	Index	Explanation
1	Electronic Power Steering (EPS)	7	Instrument panel (KOMB)
2	Power distribution box, engine compartment	8	Central gateway module (ZGM)
3	Dynamic Stability Control (DSC)	9	Digital Motor Electronics (DME)
4	Junction box power distribution box	10	Igniter pellet with connection
5	Integrated Chassis Management (ICM)	KI.30	Terminal 30
6	Steering column switch cluster (SZL)	KI.15N	Ignition (after-run)

Integral Active Steering

Integral Active Steering (IAL) is an innovative and logical development of the Active Steering system developed by BMW and first introduced with the launch of the F01.

With Active Steering, a steering angle amplification factor reduces the steering effort on the part of the driver and combines the capabilities of "steer by wire" systems with authentic steering feedback. By intervening in the steering independently of the driver's actions, it is also able to perform a stabilizing function in terms of vehicle handling.



Active Steering of the rear wheels is a logical extension of Active Steering and the two are combined as an all-in one system referred to as Integral Active Steering. IAL represents the combination of the already familiar Active Steering (front) and the new Rear Axle Slip Angle Control (HSR).

As an upgrade from the standard Servotronic steering system the Integral Active Steering is available as an option on most F0x vehicles. IAL cannot be ordered separately and is typically only available as part of the Dynamic Handling Package. The (ZDH) Dynamic Handling Package may also include: Electronic Damping Control, Active Roll Stabilization and Adaptive Drive.

Integral Active Steering Component Locations

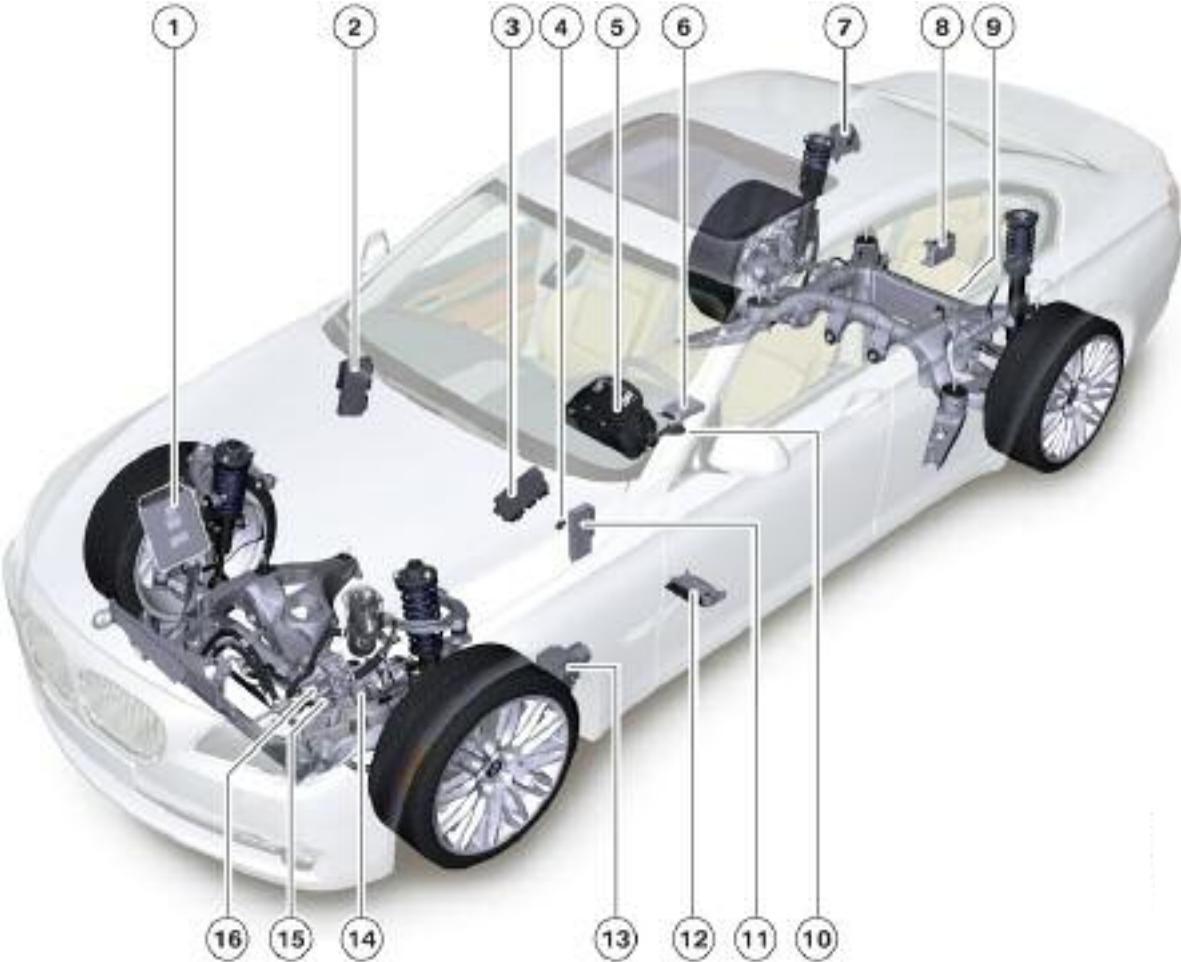

Index	Explanation	Index	Explanation
1	DME	9	Rear-wheel steering actuator (HSR)
2	Front power distribution box	10	SZL
3	CAS	11	ZGM
4	Brake light switch	12	Active Steering actuator control unit
5	Instrument cluster	13	DSC
6	Integrated Chassis Management (ICM)	14	Active Steering actuator motor with motor angular position sensor and lock
7	Rear power distribution box	15	Electronic volumetric flow control (EVV) valve
8	HSR control unit	16	Servotronic valve

Integral Active Steering System Schematic

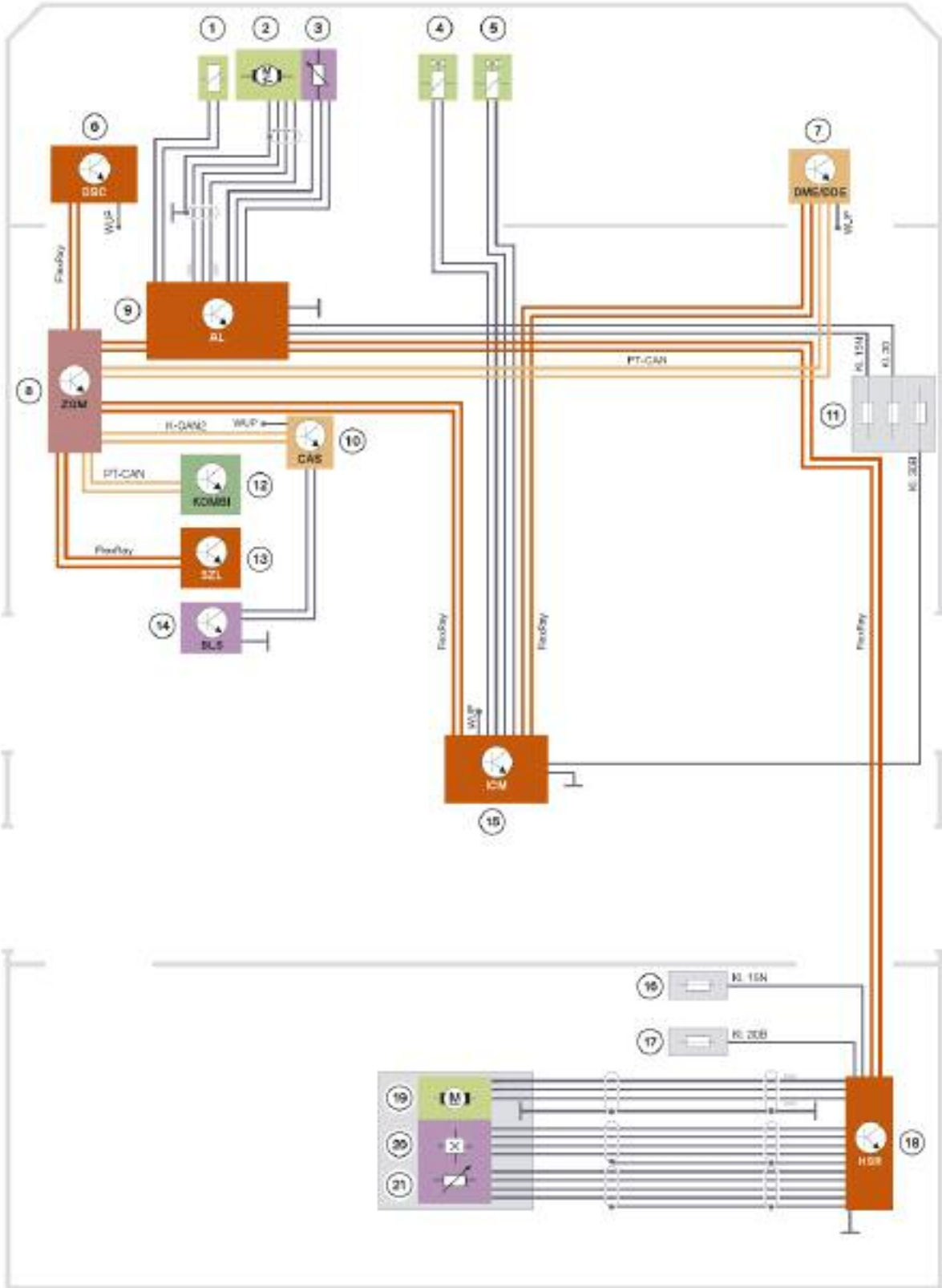

Index	Explanation	Index	Explanation
1	Active Steering lock	12	Instrument cluster
2	Active Steering electric motor	13	Steering column switch cluster
3	Active Steering motor angular position sensor	14	Brake light switch
4	Electronic volumetric flow control (EVV) valve	15	Integrated Chassis Management
5	Servotronic valve	16	Right rear power distribution box
6	Dynamic stability control	17	Battery power distribution box
7	Digital Motor Electronics	18	Rear suspension slip angle control
8	Central Gateway Module	19	HSR electric motor
9	Active Steering	20	Hall-effect sensor
10	Car Access System	21	Track-rod position sensor
11	Front power distribution box		

Overview

Implementation of the Integral Active Steering function was essentially been made possible with the introduction of the ICM system.

The Servotronic function (including valve control) is taken over by the ICM control unit. This steering control function is also influenced by the driving dynamics control switch.

Advantages of Integral Active Steering:

- Extension of Active Steering (AL) by the addition of rear-wheel steering (HSR)
- Variable steering-gear ratio (steering angle amplification factor)
- Independent control of rear-wheel steering angle (steer by wire)
- Servotronic
- Handling stabilization functions
- Reduction of braking distance under split surface braking conditions.

Signals from External Sensors

The ICM control unit reads the following signals that are essential to the Integral Active Steering from external sensors:

- Four wheel-speed signals sent via Flexray by the DSC
- Steering angle sent via FlexRay by steering column switch cluster
- Status of AL and HSR actuators transmitted via Flexray.

However, because the rear-wheels are steerable, the steering angle of the front wheels alone is not definitive for dynamic handling control purposes.

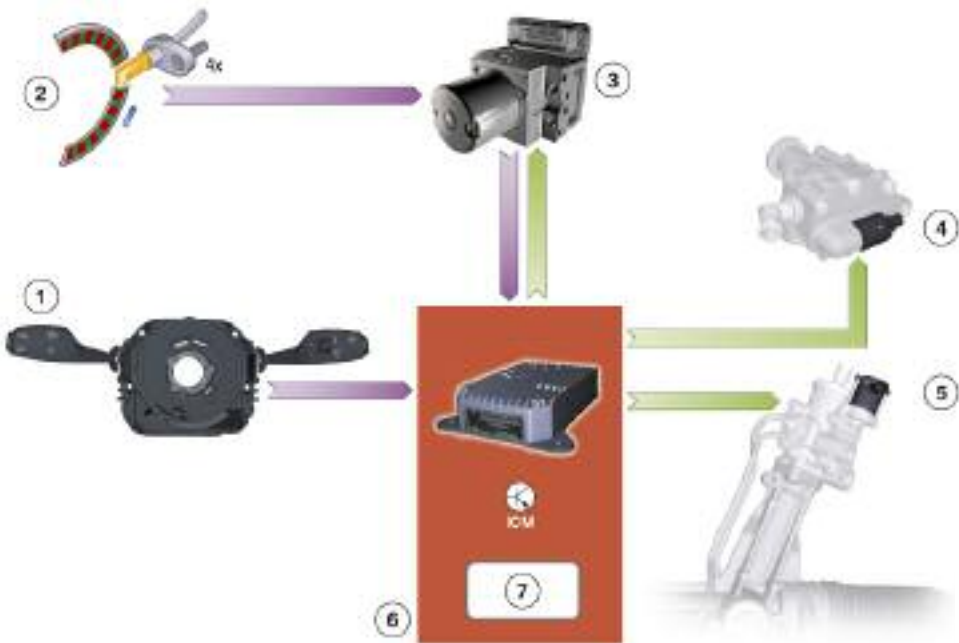

Index	Explanation	Index	Explanation
1	SZL	5	Servotronic valve
2	Wheel speed sensor	6	Integrated Chassis Management
3	Dynamic Stability Control	7	“Steering Control” function of ICM
4	Electronic volumetric flow control valve (EVV)		

Therefore, the ICM control unit also takes the steering angle of the rear wheels into account. Ultimately, the effective steering angle is calculated from the two steering angles (front and rear wheels).

The effective steering angle indicates the angle to which the front wheels would have to be turned to bring about the same vehicle response without steerable rear wheels.

That variable is the easiest for all vehicle systems to use to analyze the steering action.

Distributed Functions

ICM and actuator control units The distribution of functions between the ICM and the other dynamic handling control units in the case of Integral Active Steering is described below.

The Integrated Chassis Management is the control unit which computes the higher-level dynamic handling control functions for the Integral Active Steering.

From the current vehicle handling status and the desired course indicated by the driver, the Integrated Chassis Management calculates individual settings for the variable steering gear ratio and the superimposed yaw rate.

Once they have been prioritized, the ICM provides a required setting in each case for the AL and HSR control units. The setting specified is a required steering angle to be applied to the front and rear wheels respectively.

The AL control unit receives the required setting and has the main job of controlling the actuators so as to correctly apply the specified setting. Thus, the AL Active Steering control unit is purely an actuator control unit.

The same applies to the HSR control unit. It too is an actuator control unit. Like the AL control unit, it is responsible only for implementing the required steering angle specified by the ICM.

With the introduction of the ICM on the E71, this type of function distribution was used for the first time.

Since the F01/F02, it has been expanded to the extent that:

- the ICM now controls all linear and lateral dynamics systems (AL, HSR and also DSC).
- the ICM is the master control module both for linear dynamics and unstable handling situations.

The interface between the Integrated Chassis Management and the Dynamic Stability Control (DSC) represents a special case.

ICM Input / Output Diagram

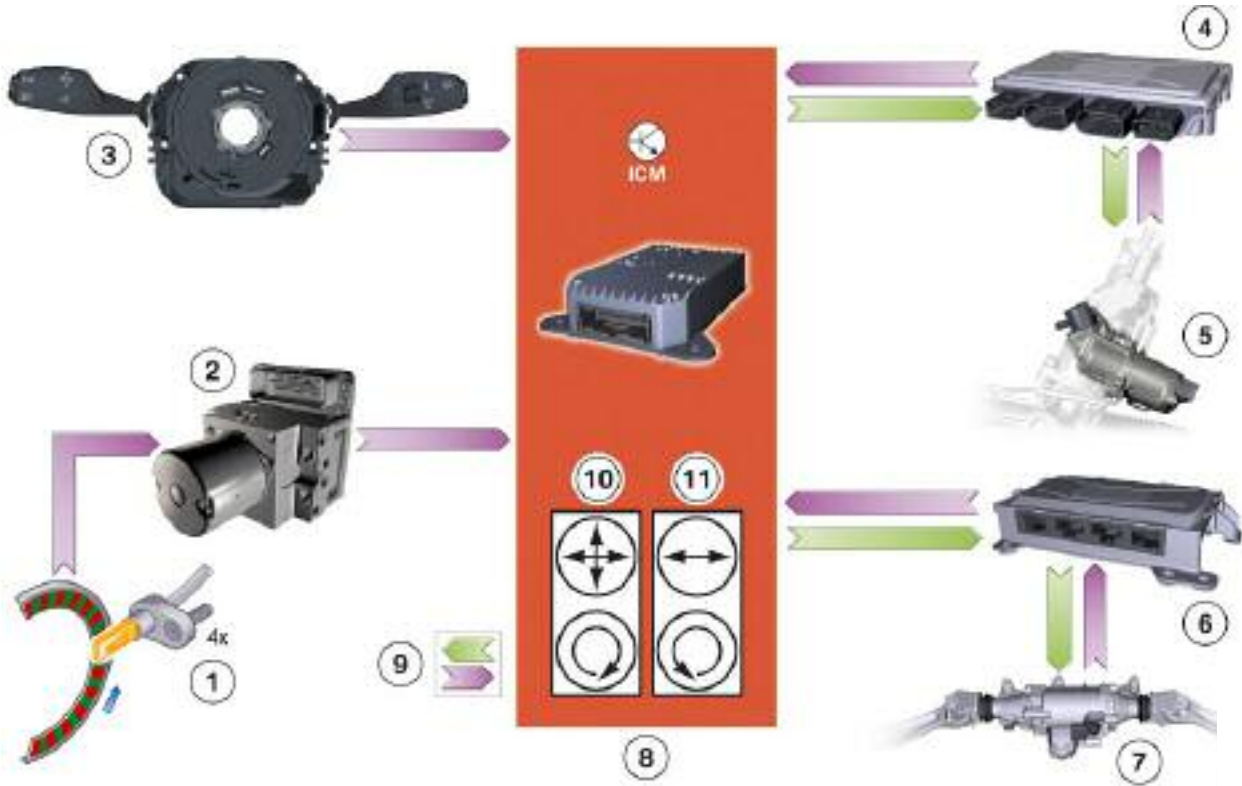

Index	Explanation	Index	Explanation
1	Wheel speed sensors	7	HSR actuating unit
2	Dynamic Stability Control (DSC)	8	ICM
3	SZL (with steering angle sensor)	9	Input and Output signals (other)
4	Active Steering control module	10	Integrated DSC sensor linear, lateral acceleration and yaw rate
5	Active Steering Actuating Unit	11	Integrated DSC sensor lateral acceleration and yaw rate
6	HSR control module		

Components of Integral Active Steering w/ Hydraulic Steering

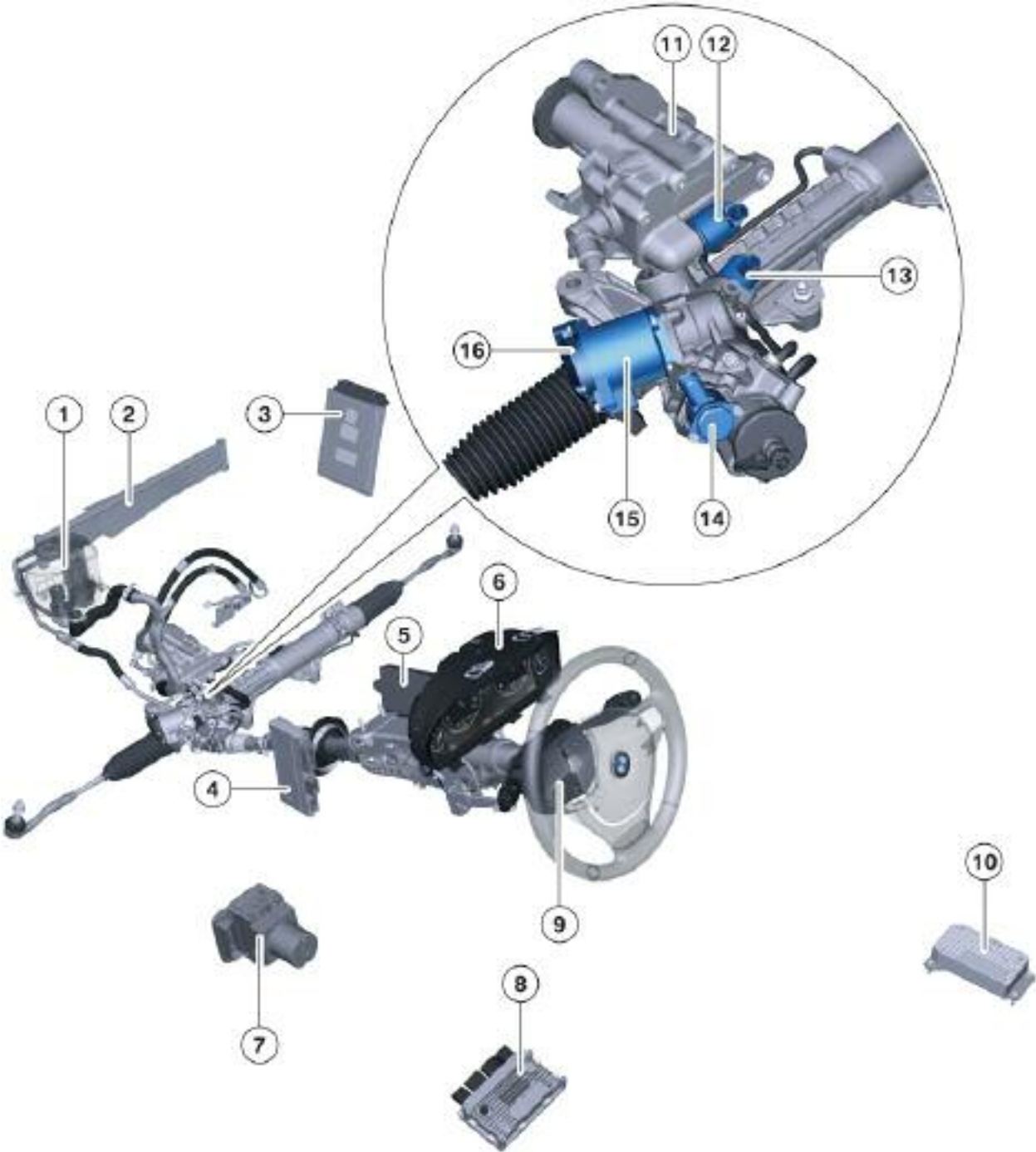

Components Overview for Active Steering (front)

Index	Explanation	Index	Explanation
1	Hydraulic fluid reservoir	9	SZL
2	Power steering cooler	10	ICM
3	DME	11	Hydraulic pump
4	ZGM	12	Electronic volumetric flow control (EVV) valve
5	CAS	13	Lock
6	Instrument cluster	14	Servotronic valve
7	DSC	15	Actuator unit electric motor
8	AL	16	Motor angular position sensor

Rear Axle Steering Control

Previously the state of the art that control systems were largely independent of one another. A central ICM control unit in the ICM architecture replaces the previous dynamic handling sensors and forms a central dynamic handling controller.

The special actuator on the rear suspension is fixed underneath a mounting plate on the rear suspension subframe.

The electro-mechanical actuator is positioned between the two new track rods of the Integral V rear suspension. The rear-wheel steering system has its own actuator control unit which is responsible for controlling and monitoring the actuator.

The electromechanical actuator essentially consists of an electric motor which moves the two track rods by means of a worm-and-nut steering gear.

The actuator is designed for a maximum travel of ± 8 mm, which brings about a maximum steering angle of $\pm 3^\circ$ at the wheels.

Integral Active Steering Rear Components

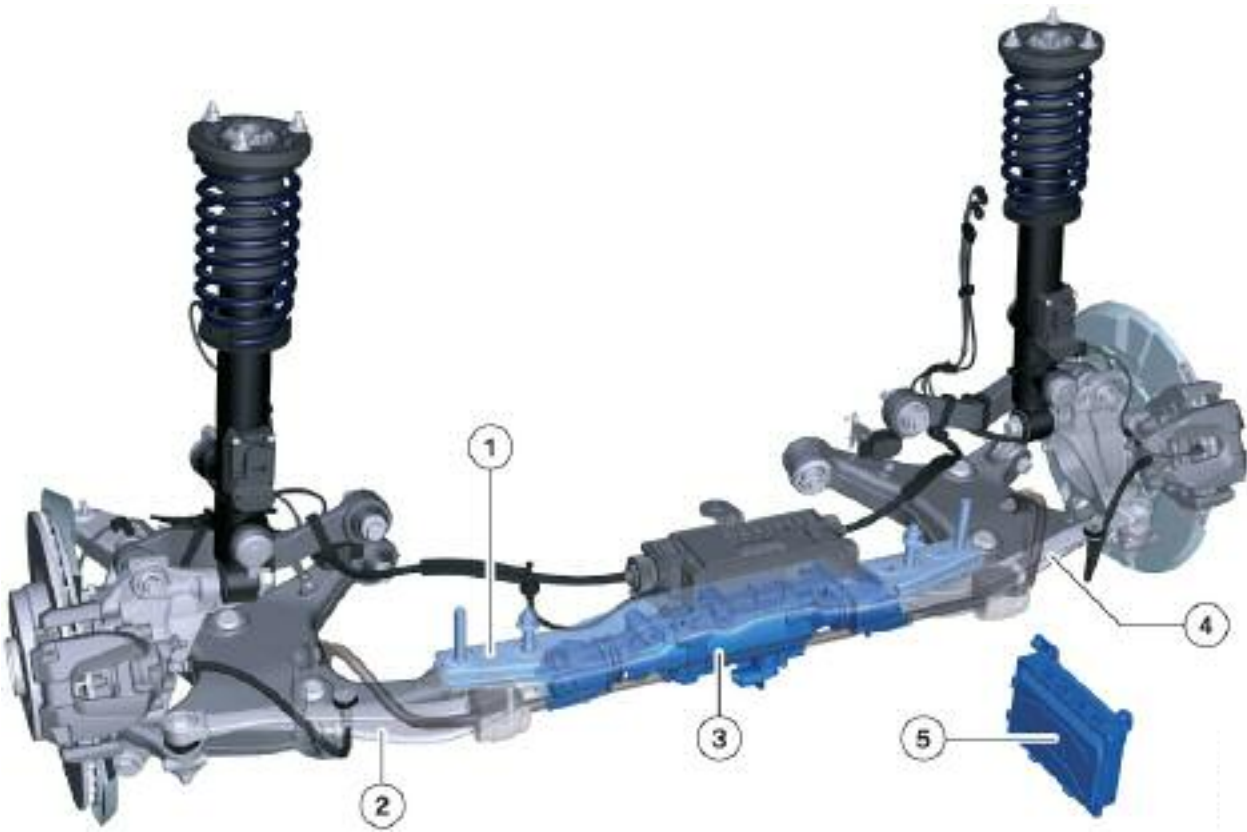

Index	Explanation	Index	Explanation
1	Mounting plate	4	Right track rod
2	Left track rod	5	HSR control module
3	HSR actuator		

The worm-and-nut rear-wheel steering gear is self-inhibiting. That means that if the system fails, the vehicle adopts exactly the same handling characteristics as a vehicle without rear-wheel steering.

HSR Actuator Components

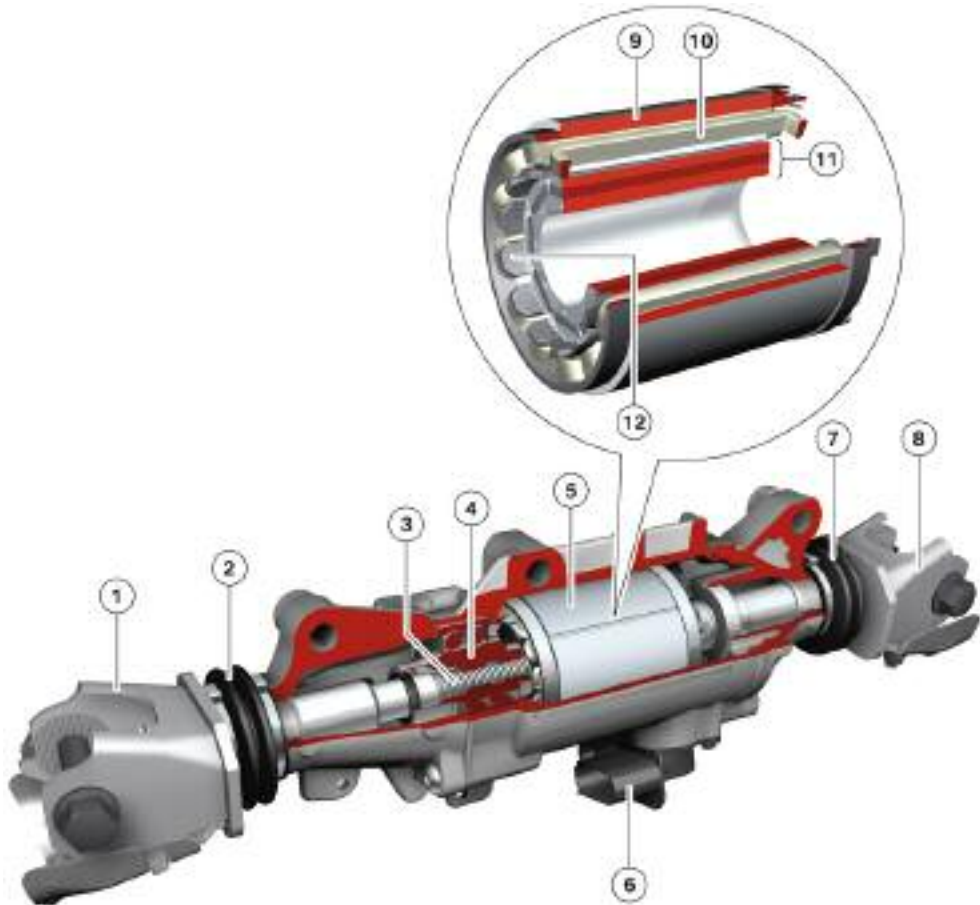

Index	Explanation	Index	Explanation
1	Left track rod joint	7	Right shaft bellows (gaiter)
2	Left shaft bellows (gaiter)	8	Right track rod joint
3	Worm shaft	9	Iron jacket
4	Worm nut	10	Stator windings
5	Electric motor	11	Permanent magnet
6	Electrical connector	12	Carrier armature winding iron core

Functions of Integral Active Steering

Low Speed Range

The variable steering-gear ratio of the Active Steering component reduces steering effort to approximately 2 turns of the steering wheel from lock to lock.

In the low speed range up to approximately 37 mph, the variable steering-gear ratio for the front wheels is combined with a degree of opposite rear-wheel steer. The effect is to increase the vehicle agility.

Momentary Axis Comparison

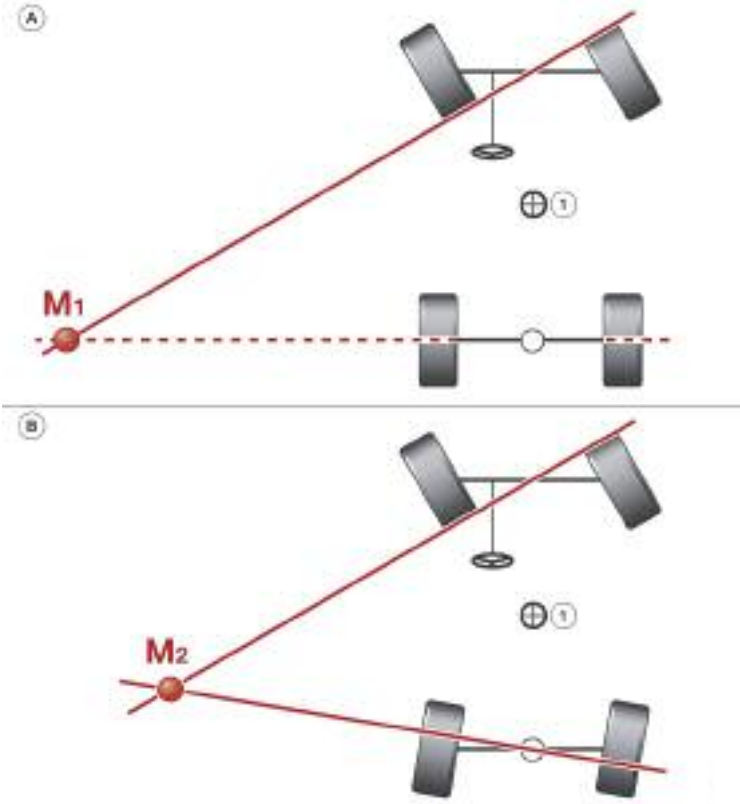

Index	Explanation	Index	Explanation
A	Conventional steering system	M2	Momentary axis 2
B	Integral Active Steering	1	Vehicle center point
M1	Momentary axis 1		

When the steering wheels of a vehicle are turned, it follows a curved path around what is called the momentary axis "M".

In the case of conventional vehicles, that momentary axis is positioned at a point along the extension of a line passing through the center of the rear wheels.

Active Steering intervention turns the rear wheels in the opposite direction at speeds up to approximately 37 mph.

The consequence of the rear-wheel steering intervention is that the axis of rotation moves closer to the center of the vehicle with the same amount of steering effort.

In terms of agility and dynamic handling, that is equivalent to a vehicle with a shorter wheelbase.

Momentary Axis at Low Speed

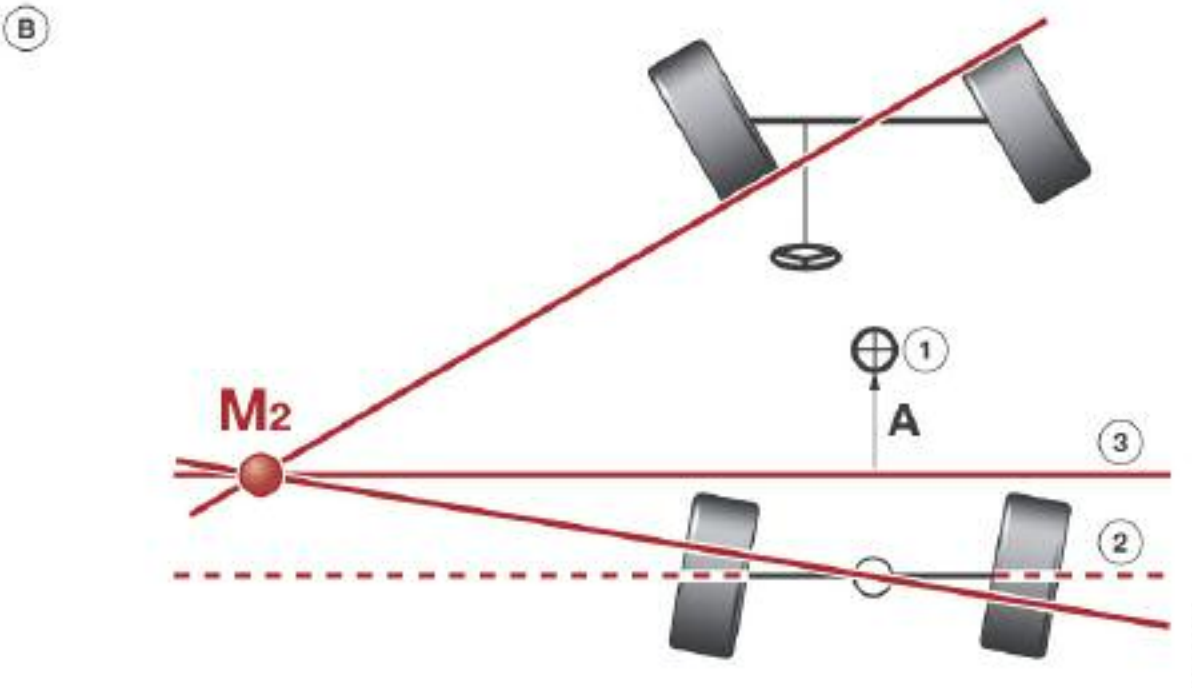

Index	Explanation	Index	Explanation
A	Conventional steering system	1	Vehicle center point
B	Integral Active Steering	2	Straight line through center of rear wheels
M2	Momentary axis 2	3	Axis of rotation, closer to vehicle center

High Speed Range

As the vehicle speed increases, the degree of steering angle amplification by the Active Steering component is reduced. The steering gear ratio becomes less direct.

At the same time, the steering strategy adopted by the Integral Active Steering changes. Whereas, at low speeds, the rear wheels are steered in the opposite direction to the front wheels, at higher speeds the rear wheels are steered in the same direction as the front.

The momentary axis moves further back, equivalent to a vehicle with a longer wheelbase, producing more stable straight line handling. The radius of the curve becomes longer.

Momentary Axis at High Speed

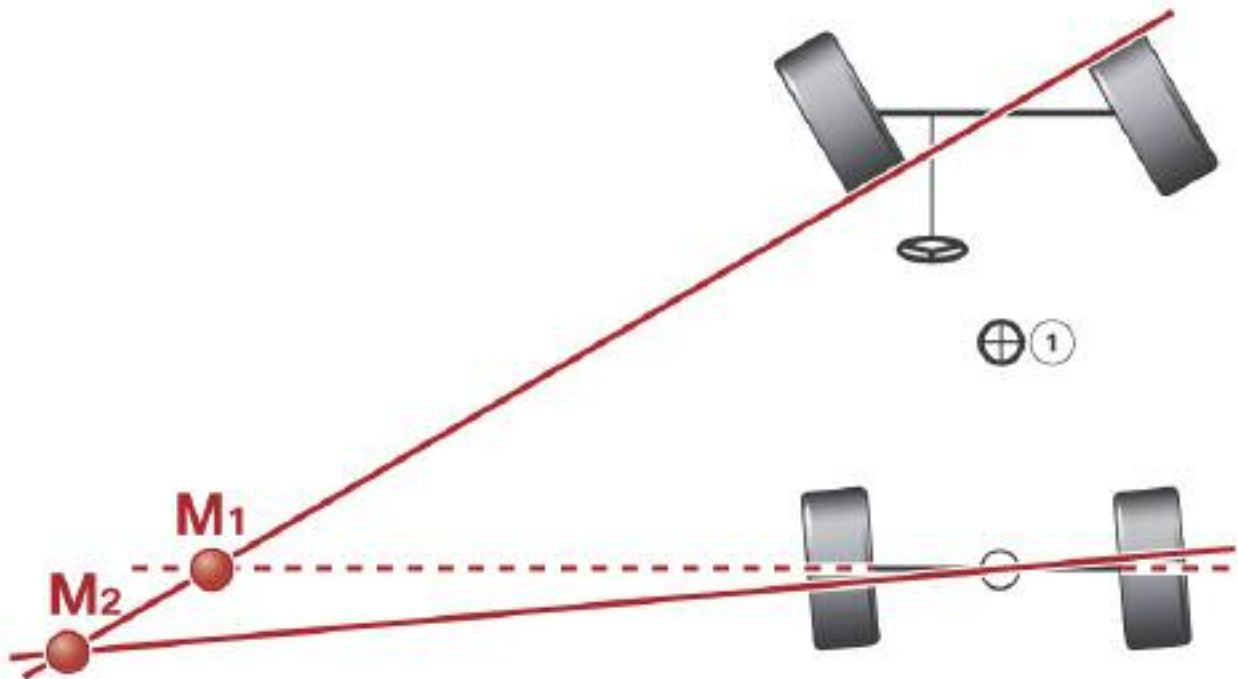

Index	Explanation	Index	Explanation
M1	Momentary axis 1	1	Vehicle center point
M2	Momentary axis 2		

By the combination with the Active Steering, an additional amount is added to the steering angle of the front wheels so that the radius of the curve and the required amount of steering lock remain at the familiar level.

All in all, coordination of the steering interventions at front and rear makes lane changes and steering maneuvers considerably easier to negotiate without sacrificing agility or balance.

Combination of the Active Steering with the new rear-wheel steering system offers benefits for the driver at all speeds.

Momentary Axis Comparison
Low Speed vs. High Speed

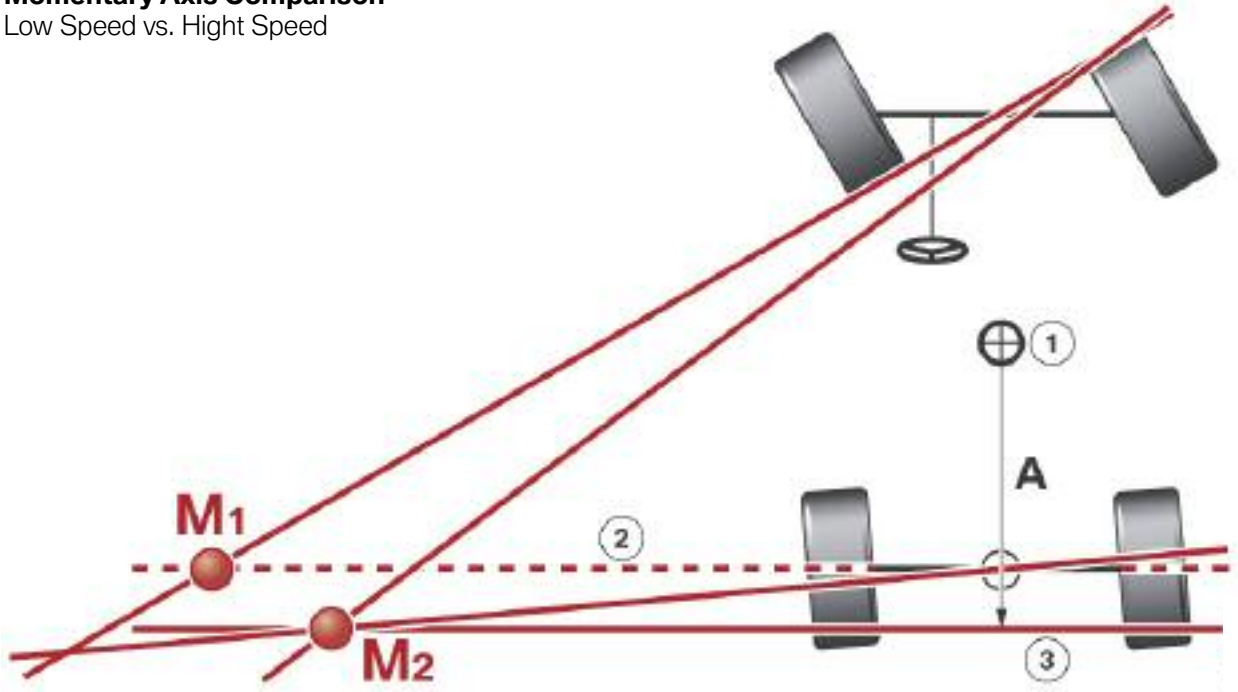

Index	Explanation	Index	Explanation
M1	Momentary axis 1	1	Vehicle center point
M2	Momentary axis 2	2	Straight line through center of rear wheels
A	Effective wheelbase increase	3	Axis of rotation further from vehicle center

Handling Stabilization by IAL when Understeering

When changing lanes quickly, all vehicles have a tendency to produce a significant yaw response and can sometimes start to oversteer.

If the ICM dynamic handling controller detects a difference between the response desired by the driver and the reaction of the vehicle, it initiates co-ordinated steering interventions on the front and rear wheels.

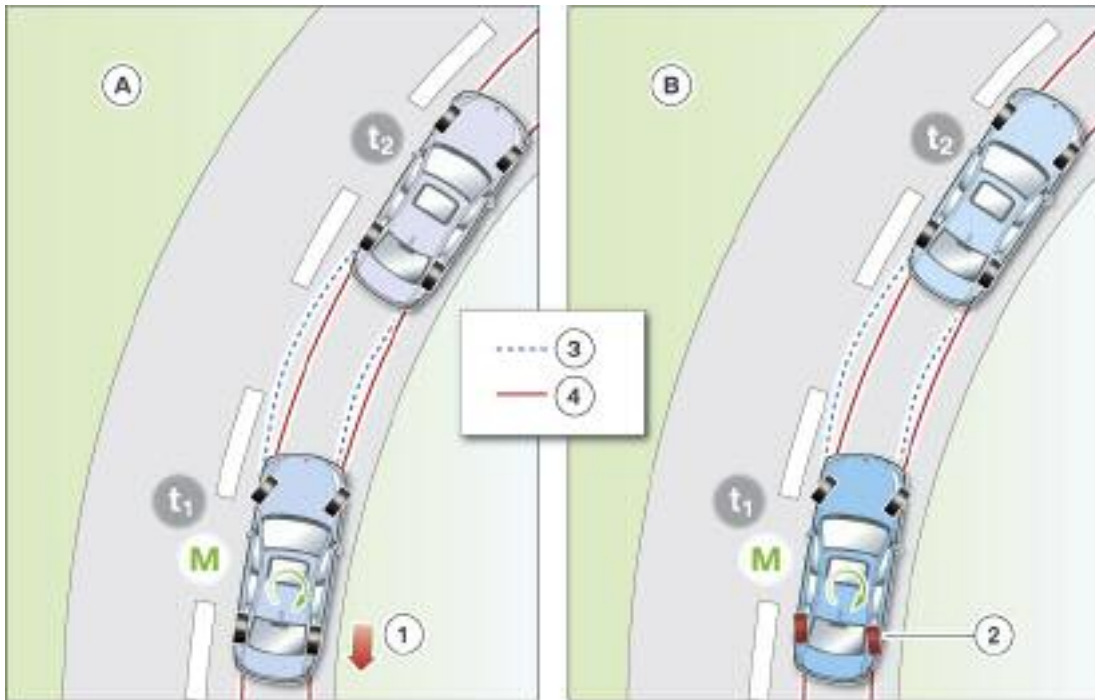

Index	Explanation
A	Prevention of understeer by individual brake modulation (DSC)
B	Prevention of understeer by rear-wheel steering intervention (IAL)
1	Individual brake modulation (DSC)
2	Rear-wheel steering intervention (IAL)
3	Course of an understeering vehicle
4	Course of a vehicle with neutral handling
M	Yaw force acting on the vehicle as a result of dynamic handling system intervention

The speed of the stabilizing intervention is such that it is hardly discernible by the driver. Braking interventions by the DSC, which have a decelerating effect, can be largely dispensed with.

The end result is that the vehicle is more stable and more effectively damped. If the driver underestimates how sharp a bend is when driving quickly on a country road, he/she can be caught out by sudden understeer.

By virtue of its inherent features, Active Steering was only able to react to vehicle oversteer. Integral Active Steering incorporating active rear-wheel steering is now also able to make corrective interventions when the vehicle is oversteering and thus further increases active safety.

■ Handling Stabilization by Integral Active Steering Under μ -split Braking Conditions

Hard braking on road surfaces which provide less grip for the wheels on one side of the vehicle than on the other causes the vehicle to yaw towards the side with more grip. Under emergency braking, the driver of a conventional vehicle then has to correct the vehicle's course.

Under such μ -split braking conditions, the dynamic handling controller generates a stabilizing yaw force by opposite steering interventions on the front and rear wheels.

A) Without DSC

In the case of a vehicle without DSC, maximum braking effect is achieved by the wheels on the dry side of the road, while those on the wet or icy side produce very little retardation.

As a result, a very substantial yaw force acting in an counterclockwise direction is produced, causing the vehicle to swerve to the right.

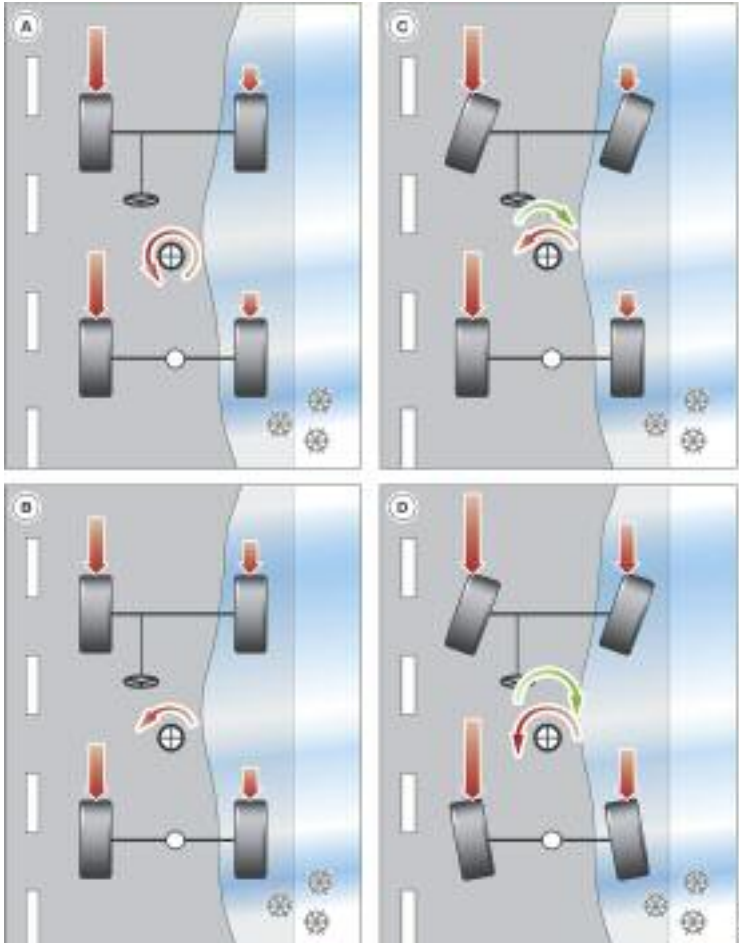

Index	Explanation
A	Vehicle without DSC
B	Vehicle with DSC
C	Vehicle with DSC and AL (i.e. E90 w/yaw force compensation)
D	Vehicle with DSC and IAL

Integral Active Steering Special Function

Quite obviously, Active Steering systems must not be capable of being switched on or off by the driver.

In the case of Integral Active Steering, there is a special feature in that regard because if snow chains are fitted to the rear wheels, Active Steering of the rear wheels must be disabled.

When snow chains are fitted, the rear-wheel steering is deactivated in order to ensure that the wheels are always free to rotate.



Automatic snow-chain detection assists the driver and indicates the detected status on the Control Display. This does not remove the responsibility for manually changing the setting.

When snow chains are used, the setting on the iDrive Settings menu must be changed to "Show chains fitted".

If the maximum speed of 30 mph for driving with snow chains is exceeded, the rear-wheel steering is reactivated regardless of the "Snow chains fitted" setting.

■ Automatic Snow Chain Detection

It is possible to detect from the wheel-speed sensor signals a characteristic pattern produced by the motion of the wheel when snow chains are fitted (only with BMW approved snow chains). From that characteristics signal pattern, the control unit is able to detect whether snow chains are fitted on each individual wheel.

Active Steering on the E70 is part of the **lateral dynamics systems**. Nowadays, dynamic driving systems are subdivided according to their mode of operation. For example, lateral dynamics systems are those systems which influence the vehicle laterally (in a turn).

In the E70, there are two systems which are considered part of the lateral dynamics systems.

- Servotronic - Speed-dependent hydraulic steering torque assistance
- AS - Active Steering (previously AFS, Active Front Steering)

The E70 is the first all-wheel-drive vehicle to be offered with Active Steering (AS). Servotronic is only offered in conjunction with the Active Steering.

Active Steering (AS)

Active Steering was initially offered in the E60 (5 Series). Since then, a large proportion of BMW's in the 3 and 6 Series now have Active Steering. It is only the X models and other all-wheel-drive vehicles that have not yet been provided with this for reasons of space.



Index	Explanation	Index	Explanation
1	DSC Sensor	5	Fluid reservoir
2	Steering Column Switch Cluster	6	Steering gear
3	AS control unit	7	Hydraulic pump
4	AS actuating unit	8	Power steering cooler

This innovative steering system is now being offered, as an option, in an all-wheel-drive vehicle for the first time at BMW, namely in the E70.

For the most part, the active steering system on the E70 is much the same as on previous models. There are some minor changes which will be discussed in this section.

Changes to Active Steering

On the E70, certain changes have been made to the Active Steering system on the E70. They are as follows:

- The cumulative (total) steering angle sensor has been omitted.
- The ECO valve has been replaced by the Electronically Controlled Bypass Valve (EVV).
- Yaw moment compensation is now enhanced with the addition of GRR+.

Cumulative (total) Steering Angle (virtual)

With the addition of Active Steering on the E70, the total steering angle sensor has been omitted from the system. The value for the total steering angle is now a “virtual” value which is calculated from the driver’s steering angle and the motor position sensor value.

The virtual (total) steering angle value provides the same information as the total steering angle sensor. The initialization procedure still needs to be carried out when there are any changes to the system.

The initialization process has changed and differs slightly from the procedure on previous vehicles with Active Steering.

Electronically Controlled Bypass Valve (EVV)

The EVV regulates the volumetric flow of hydraulic fluid in the hydraulic pump to ensure that only the volumetric flow currently required to provide power assistance is made available.

Example:

When the vehicle is being driven straight ahead without power assistance, the circulation pressure in the steering hydraulic circuit drops, thus reducing the circulation pressure and the power consumption. If a steering movement is required, the volumetric flow is immediately raised again and the usual steering angle speed is ensured.

Hydraulic Power Steering Dyagram

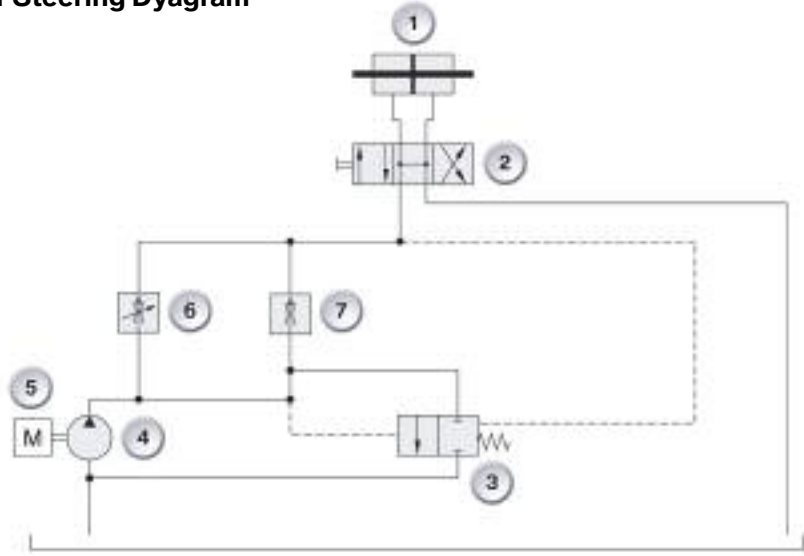

Index	Explanation	Index	Explanation
1	Rack and pinion unit	5	Engine
2	Steering valve	6	EVV
3	Flow regulating piston (in pump)	7	Throttle (restrictor)
4	Vane-cell pump		

The EVV (1) therefore controls the power consumption of the hydraulic pump, thus reducing the fuel consumption and the CO2 emissions of the combustion engine.

Hydraulic Power Steering Pump



Yaw-Rate Control Plus (GRR+)

The "yaw-rate control plus" function assists the driver when he is braking on roads with varying friction coefficients, in a similar way to the yaw moment compensation. This function represents a significant safety feature.

In the case of braking on different surface friction coefficients (asphalt/ice or snow), a moment builds up about the z or vertical axis (yaw moment) rendering the vehicle unstable.

In this special case, the Active Steering control unit calculates the steering angle (maximum $\pm 4^\circ$) required for the front wheels to keep the vehicle stable using the actual yaw rate and the longitudinal and lateral acceleration.

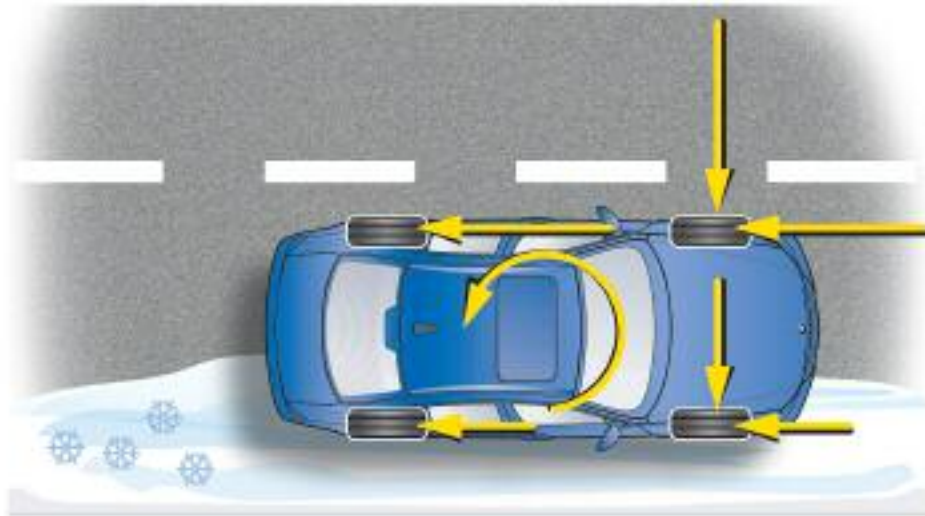

This active counter-steering creates counter-torque about the z or vertical axis (red arrow) which compensates for the earlier acting yawing force (yellow arrow).

In this way, the vehicle is stabilized by clever interaction between the DSC braking and the AS function, resulting in a new safety aspect, unique in this class.

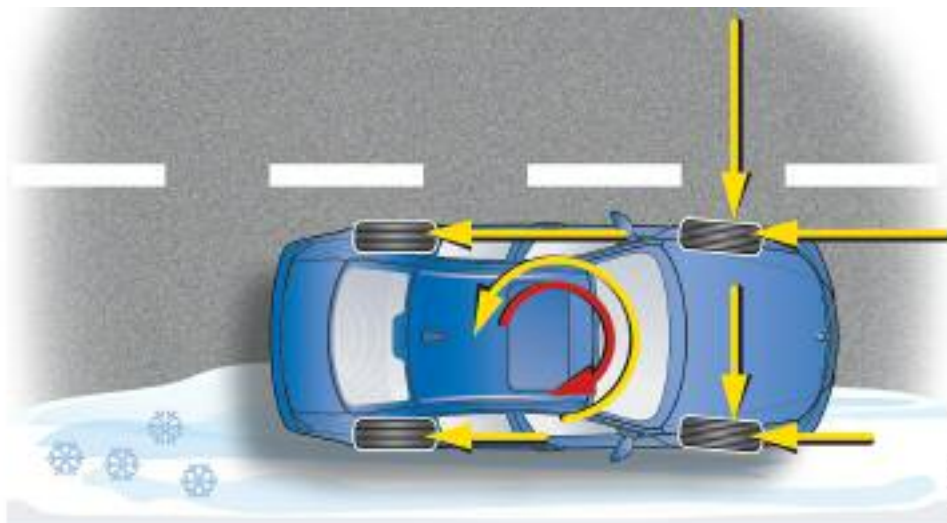

NOTES

PAGE