

Original BMW Accessories. Installation Instructions.



Retrofit - Carbon fibre package for M-package BMW 3 Series Saloon (E90) BMW 3 Series Touring (E91) BMW 3 Series Coupe (E92)

Retrofit kit No.:	51 19 0 404 056	Front apron attachment, right
	51 19 0 404 057	Front apron attachment, left
	51 12 0 404 941	Diffuser cover
	51 12 0 413 432	Front apron attachment, right
	51 12 0 413 431	Front apron attachment, left

Installation time

The installation time is **approx. 1.0 hours** for the carbon front attachments and **approx. 0.5 hours** for the diffuser.

This may vary depending on the vehicle's condition and equipment.

The vehicle must be updated to the latest I-level status by flashing before installing the retrofit. Different programming times are necessary depending on the production age of the vehicle and the work already performed on the vehicle so that no time requirements can be specified here. The installation time does not include the time required for programming/encoding which depends on the vehicle's age and equipment.

Important information

These installation instructions are primarily designed for use within the BMW dealership organisation and by authorised BMW service companies.

In any event, the target group for these installation instructions is specialist personnel trained on BMW cars with the appropriate specialist knowledge.

All work must be completed using the latest BMW repair manuals, circuit diagrams, servicing manuals and work instructions, in a rational order, using the specified tools (special tools) and observing current health and safety regulations.

In the event of installation or functional problems, limit troubleshooting to 0.5 hours for mechanical jobs and 1.0 hours for electrical jobs.

To avoid unnecessary work and costs, send a corresponding enquiry via the Aftersales Assistance Portal (ASAP) using the technical parts support application.

Please quote the following:

- Vehicle identification number
- Part number of retrofit kit
- Exact description of the problem
- Work already carried out.

Do not archive the hard copy of these installation instructions since daily updates are made by ASAP!

All pictures show LHD cars; proceed accordingly on RHD cars.

Pictograms

 Denotes instructions that draw your attention to special features.

◀ Denotes the end of the instruction or other text.

Installation information

The installation instructions describe the procedure on the right-hand side of the vehicle only. The same procedure should be followed analogously on the left-hand side of the vehicle.

Ordering information

The Betalink adhesive package K1 (Part number: 82 69 9 408 866) for E90/E91 and the Betalink adhesive package K2 are not included in the retrofit kit and must be ordered separately.

 Only use the Betalink adhesive package K2 for the E92. ◀

Special tools required

None

Contents

Section	Page
1. Parts overview for E90 and E91	4
2. Parts overview for E92	5
3. Installing front apron attachments E90 and E91	6
4. Installing front apron attachments for E92	10
5. Installing diffusor only for E90 and E91.....	12
6. Removing attachments for E90 and E91	13
7. Removing attachments for E92	15
8. Concluding work and coding for E90 and E91	16
9. Concluding work and coding for E92	17

1. Parts overview for E90 and E91

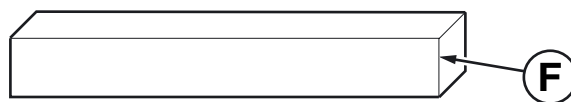
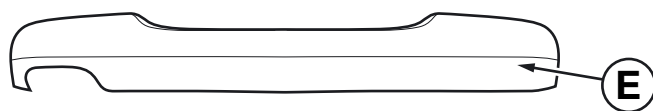
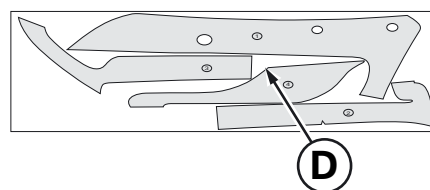
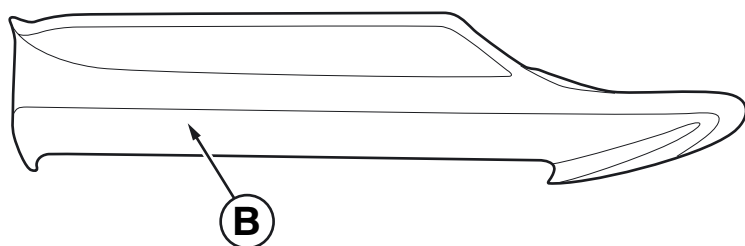
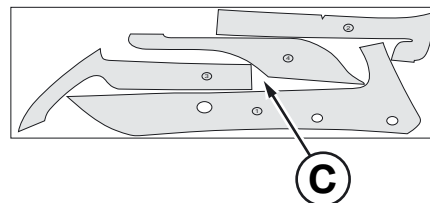
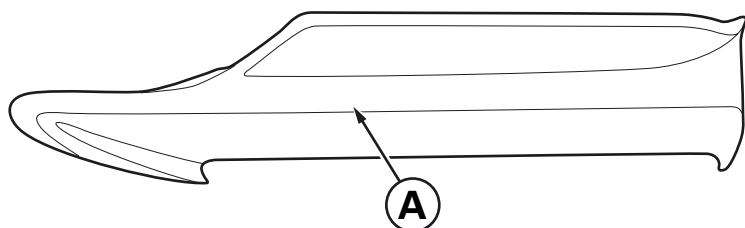

090 0090 V

Legend

- A** Front apron attachment, right
- B** Front apron attachment, left
- C** Adhesive punched blank, right (4-piece)
- D** Adhesive punched blank, left (4-piece)
- E** Diffuser
- F** Betalink K1 (not included in parts kit)

2. Parts overview for E92

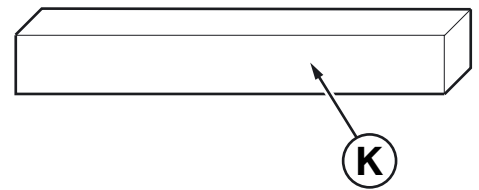
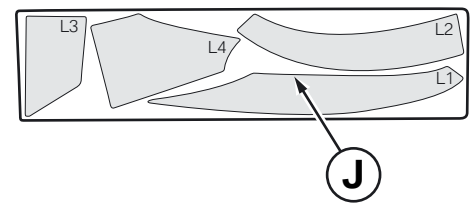
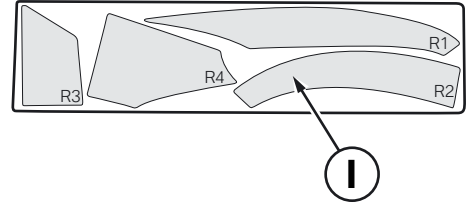
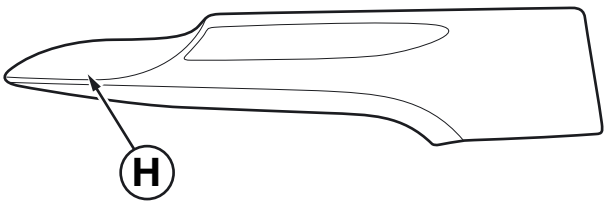
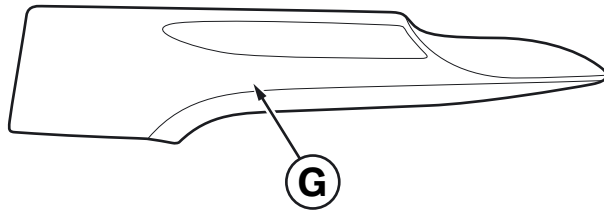

092 0201 V

Legend

- G** Front apron attachment, right
- H** Front apron attachment, left
- I** Adhesive punched blank, right (4-piece)
- J** Adhesive punched blank, left (4-piece)
- K** Betalink K2 (not included in parts kit)

3. Installing front apron attachments E90 and E91

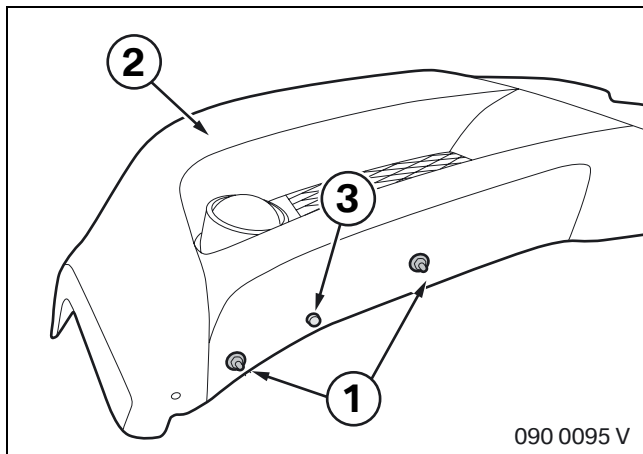

Undo screws (1) on front apron (2).
Remove expanding rivet (3).

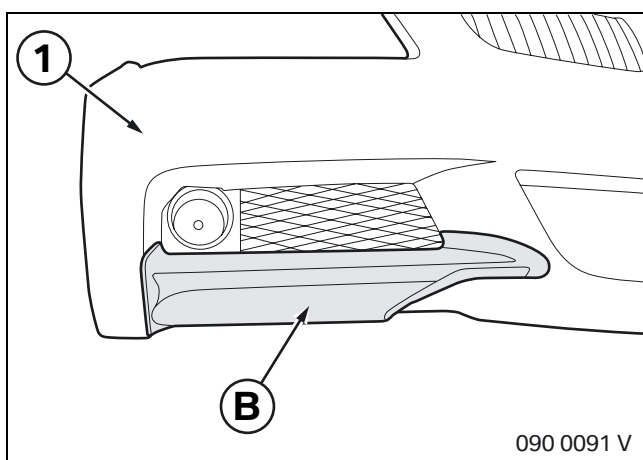

Place front apron attachment **B** on front apron (1).
 It must be possible to completely remove the marks. ◀
Mark outline of the attachment on the front apron (1).

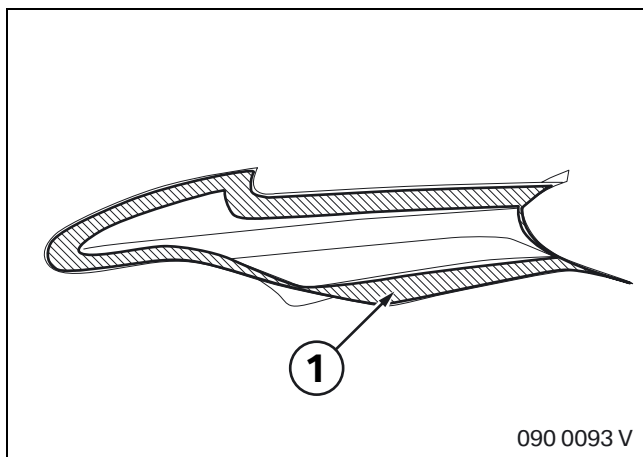

Roughen hatched area (1) on inside of front apron attachments with abrasive paper from the Betalink package.
Thoroughly clean area with supplied Betalink cleaner.

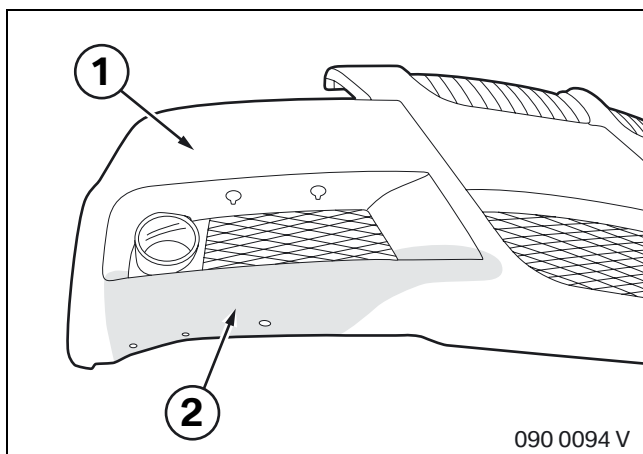

 Make sure that the Betalink cleaner does not come in contact with the fog lights, grille and trim. ◀
Clean front apron (1) in illustrated area (2) with Betalink cleaner.

3. Installing front apron attachments for E90 and E91

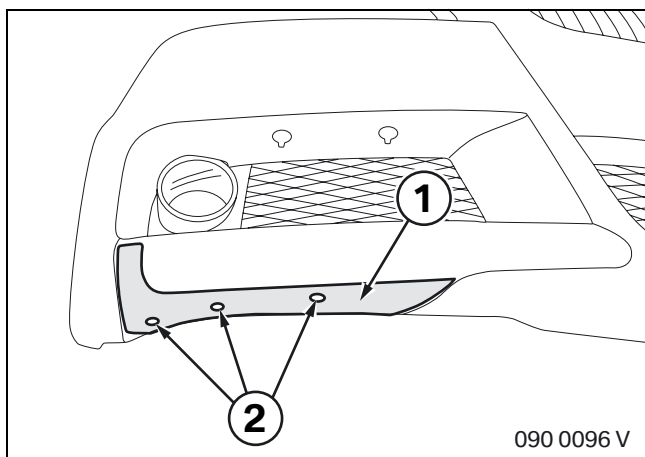

Align adhesive strip **1** with holes (2) and adhere in position.

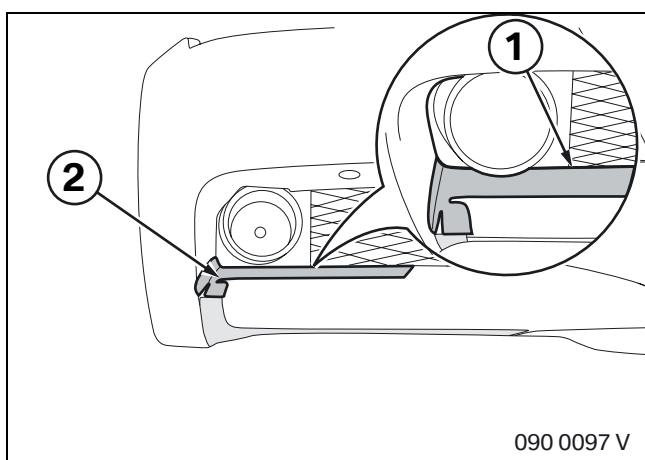

Align adhesive strip **2** at edge (1) with the grille and adhere in position.

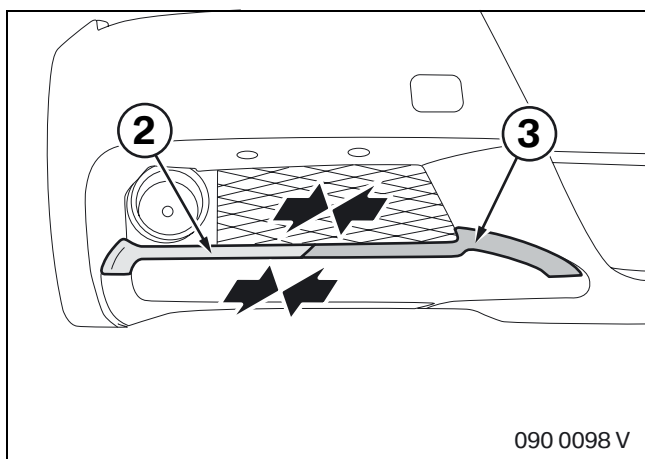

Place adhesive strip **3** exactly against the edge of adhesive strip **2** and adhere in position.

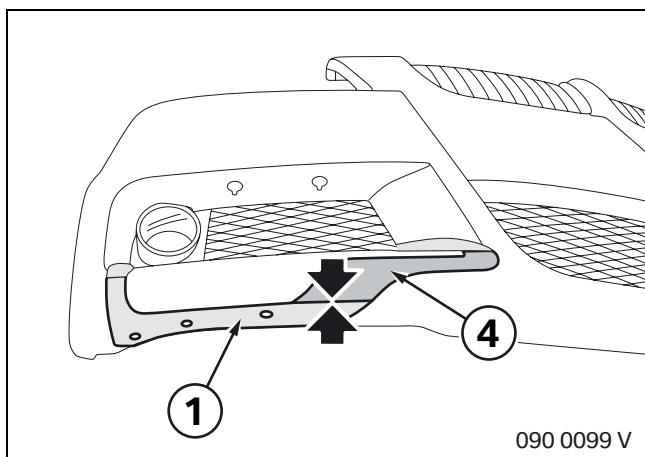

Place adhesive strip **4** exactly against the edge of adhesive strip **1** and adhere in position.

▣ If necessary use the blade contained in the Betalink adhesive package to smooth out any bubbles in the adhesive strips. ◀

Remove protective film from all adhesive strips.

3. Installing front apron attachments for E90 and E91

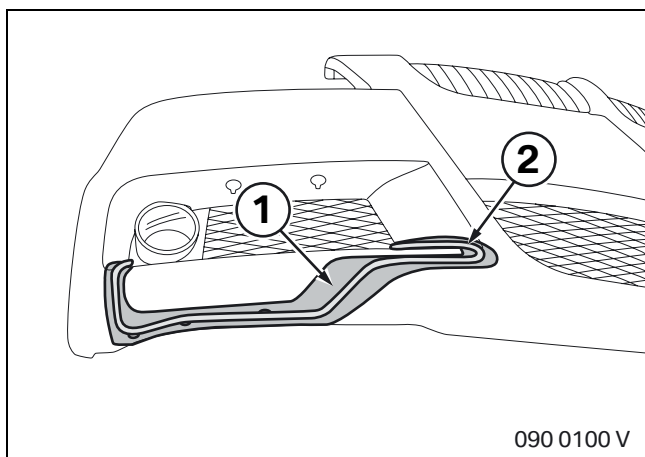

Clean the adhesive strips (1) with Betalink cleaner.
Apply a 4 mm diameter bead of Betalink adhesive (2) onto the adhesive strips (1).

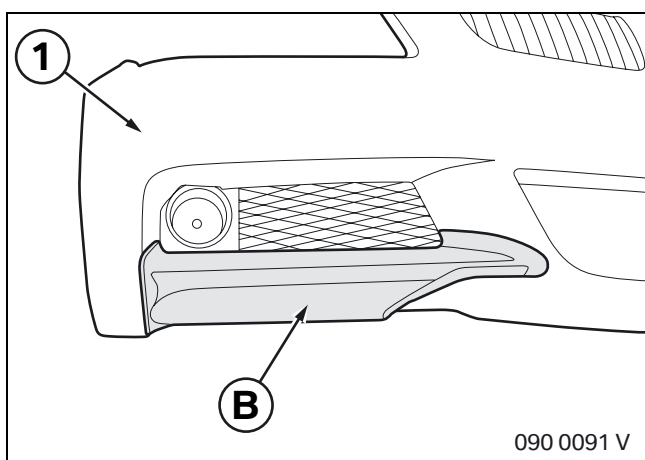

Slightly spread apart the front apron attachment **B** and carefully slide onto the front apron (1).

 Remove excess Betalink adhesive with Betalink cleaner. ◀

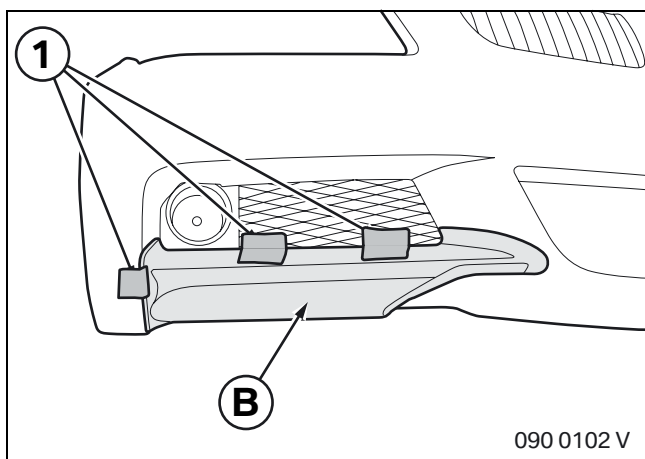

Check the fit of the front apron attachment **B** at all edges and correct if necessary.

Secure front apron attachment **B** with adhesive tape (1).

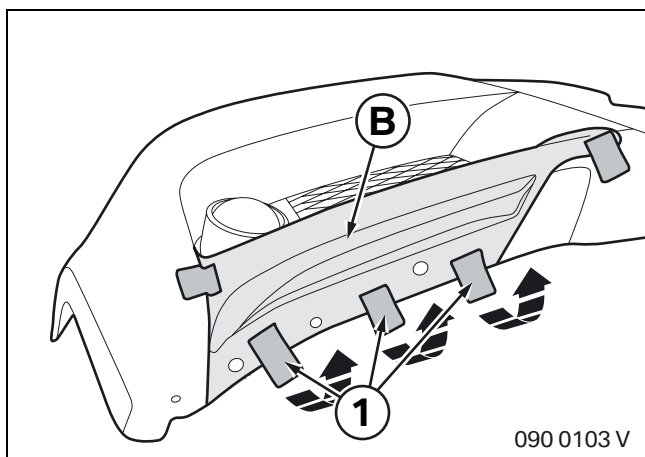

Wrap adhesive tape (1) around lower area of front apron attachment **B**.

3. Installing front apron attachments for E90 and E91

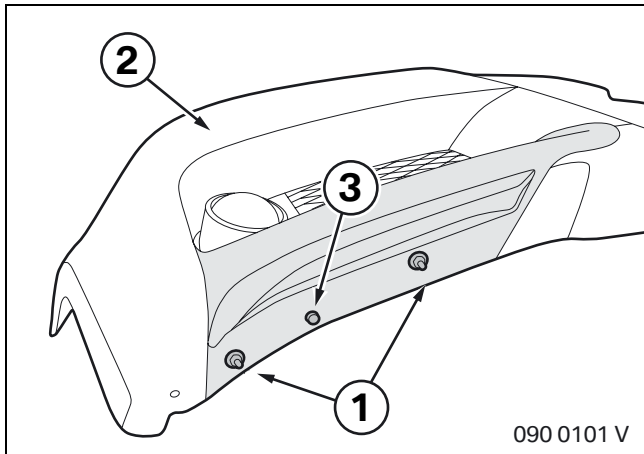

Install screws (1) on front apron (2).
Fit expanding rivet (3).

4. Installing front apron attachments for E92

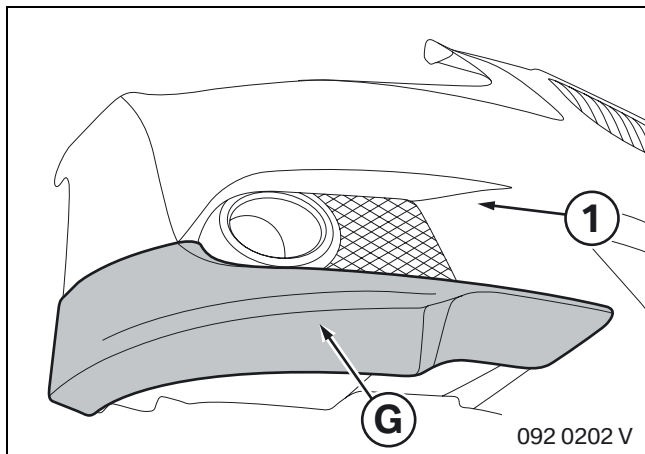

Place front apron attachment **G** on front apron (1).

▣ It must be possible to completely remove the marks. ◀

Mark outline of the attachment on the front apron (1).

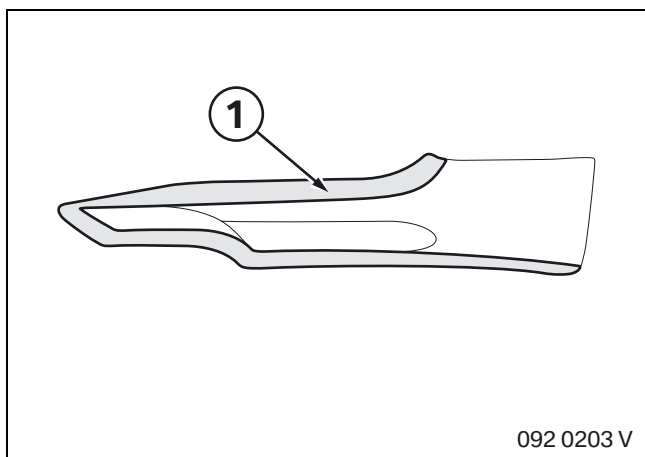

Roughen marked area (1) on inside of front apron attachments with abrasive paper from the Betalink package.

Thoroughly clean area with supplied Betalink cleaner.

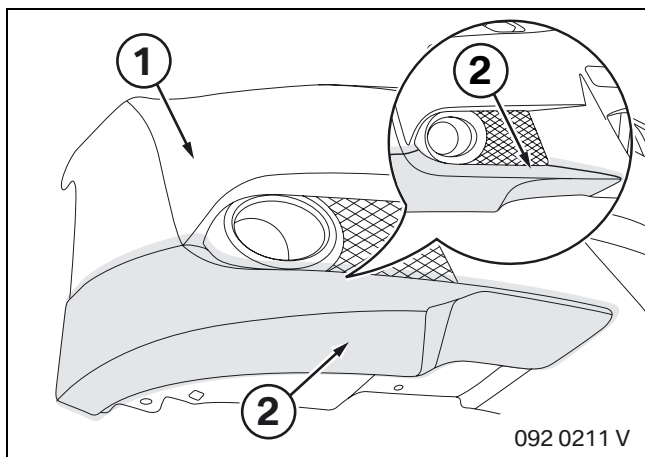

▣ Make sure that the Betalink cleaner does not come in contact with the fog lights, grille and trim. ◀

Clean front apron (1) in illustrated area (2) with Betalink cleaner.

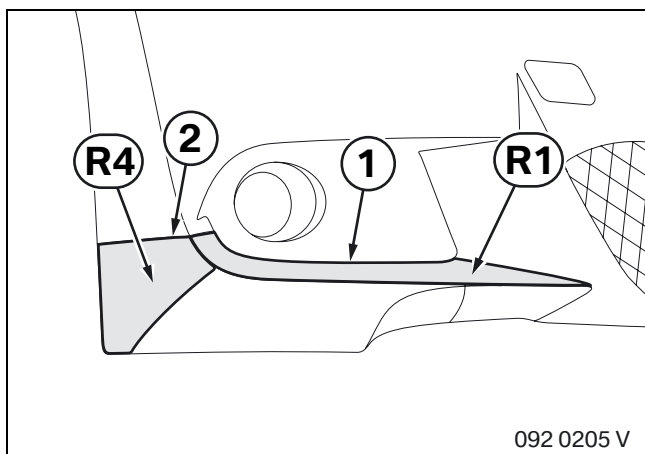

Align adhesive strip **R1** with marking (1) and adhere in position.

Align adhesive strip **R4** at edge (2) with the grille and adhere in position.

4. Installing front apron attachments for E92

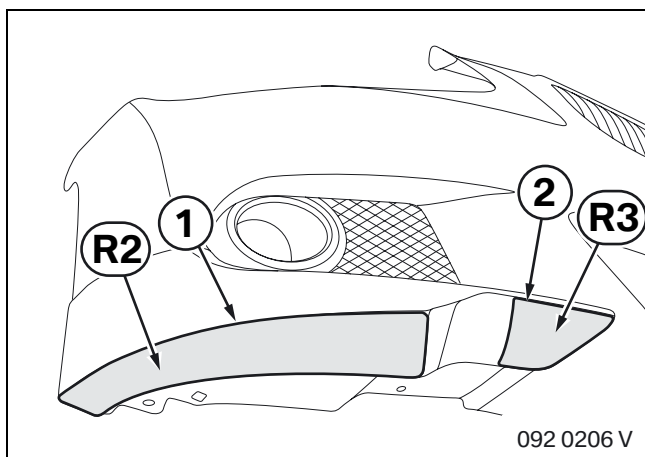

Place adhesive strip **R2** exactly against the edge of adhesive strip (1) and adhere in position.

Place adhesive strip **R3** exactly against the edge of adhesive strip (2) and adhere in position.

▶ If necessary use the blade contained in the Betalink adhesive package to smooth out any bubbles in the adhesive strips. ◀

Remove protective film from all adhesive strips.

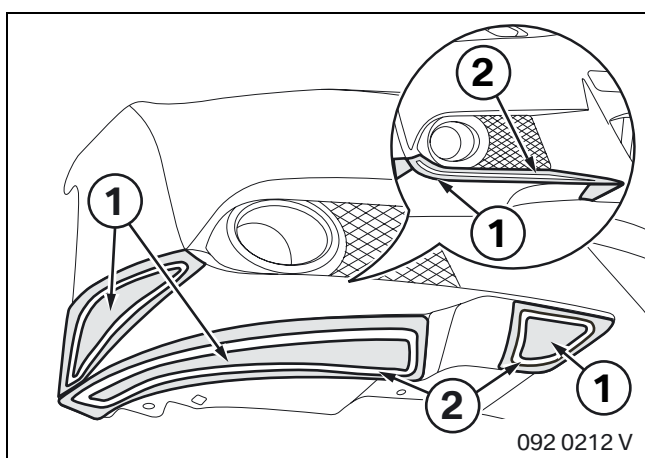

▶ Only use Betalink adhesive K2. ◀

Clean the adhesive strips (1) with Betalink cleaner.

Apply a 4 mm diameter bead of Betalink adhesive (2) onto the adhesive strips (1).

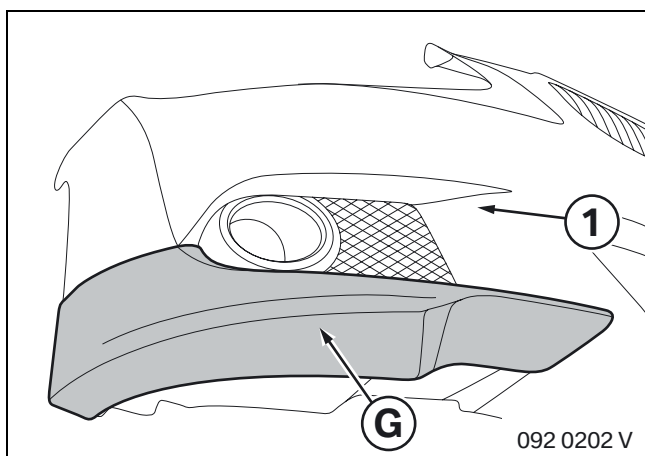

Slightly spread apart the front apron attachment **G** and carefully slide onto the front apron (1).

▶ Remove excess Betalink adhesive with Betalink cleaner. ◀

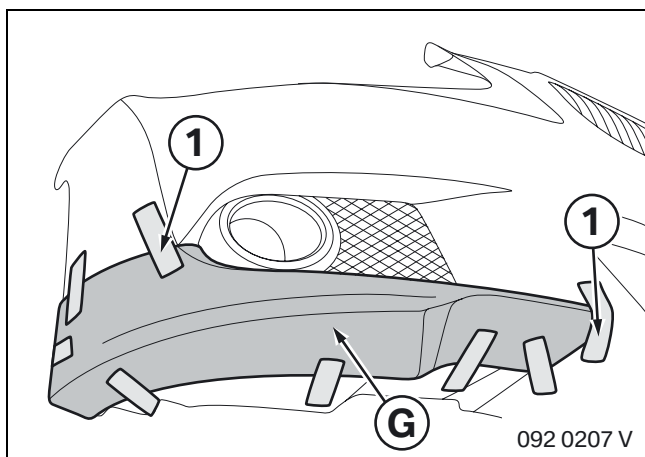

Check the fit of the front apron attachment **G** at all edges and correct if necessary.

Secure front apron attachment **G** with adhesive tape (1).

Wrap adhesive tape (1) around lower area of front apron attachment **G**.

5. Installing diffusor only for E90 and E91

Replace standard diffuser, TIS No. 51 12 ... by diffusor **E**.

6. Removing attachments for E90 and E91

- ▶ It is not possible to remove the attachments without destroying them.
Damaged attachments should be removed and replaced by new parts. ◀

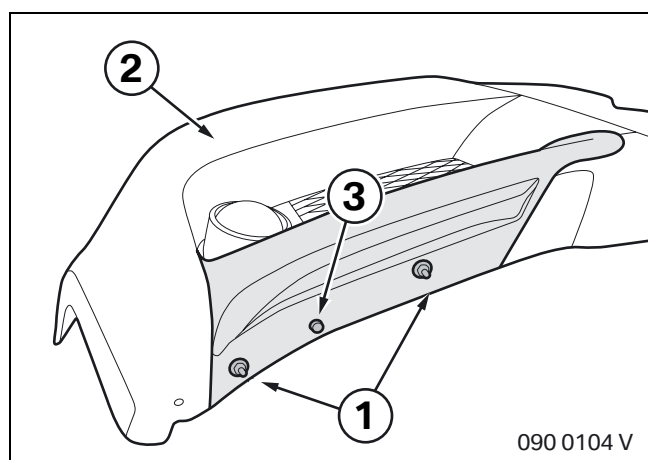

Undo screws (1) on front apron (2). Release underride guard.

Remove expanding rivet (3).

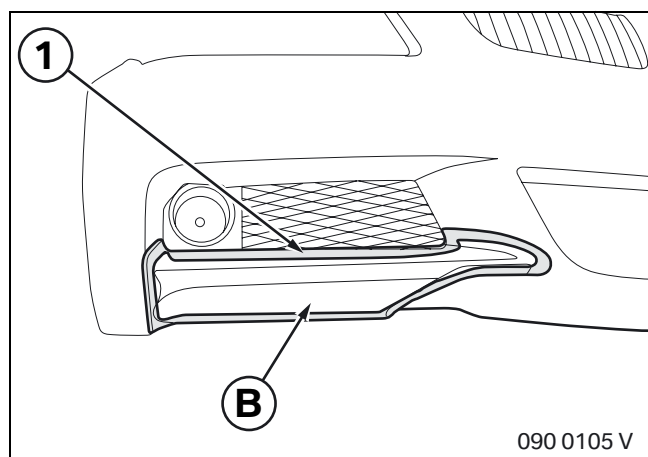

- ▶ The temperature of the hot-air blower should not exceed 60°C.

Make sure that the fog lights, grille and painted areas of the front apron are not damaged. ◀

Heat up front apron attachment **B** and front apron in area (1) as illustrated.

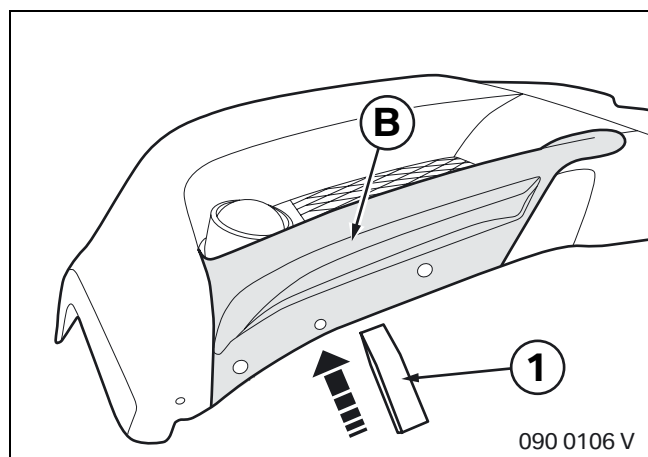

- ▶ Make sure that the front apron is not damaged. ◀

Use screwdriver or wedge (1) to carefully release the front apron attachment **B**.

6. Removing attachments for E90 and E91

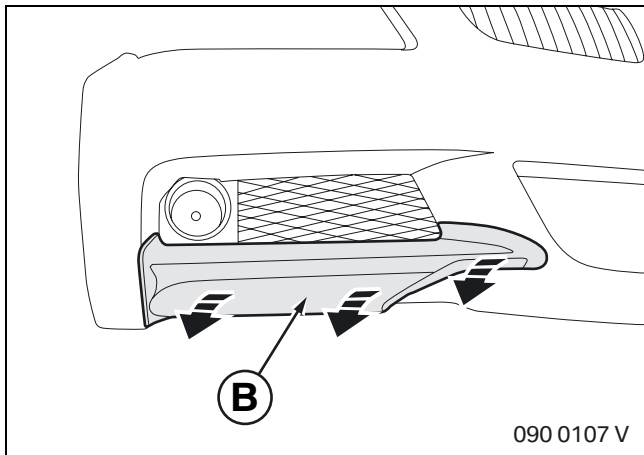

▶ Make sure that the fog lights, grille and painted areas of the front apron are not damaged. ◀

Pull out front apron attachment **B** from below, turn upward and pull or break off.

Use hot-air blower and Betalink cleaner to remove all adhesive residue.

7. Removing attachments for E92

- ▶ It is not possible to remove the attachments without destroying them.
Damaged attachments should be removed and replaced by new parts. ◀

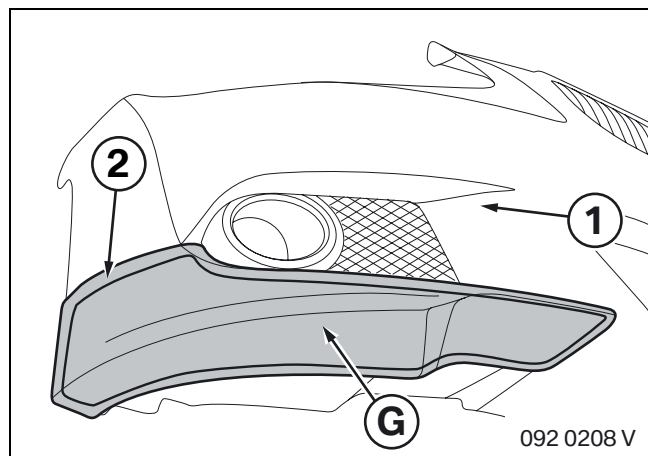

- ▶ The temperature of the hot-air blower should not exceed 60°C.

Make sure that the fog lights, grille and painted areas of the front apron are not damaged. ◀

Heat up front apron attachment **G** and front apron (1) in area (2) as illustrated.

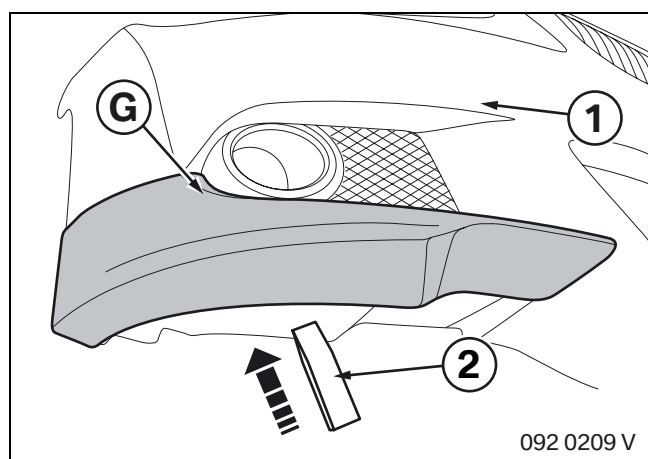

- ▶ Make sure that the front apron (1) is not damaged. ◀

Use screwdriver or wedge (2) to carefully release the front apron attachment **G**.

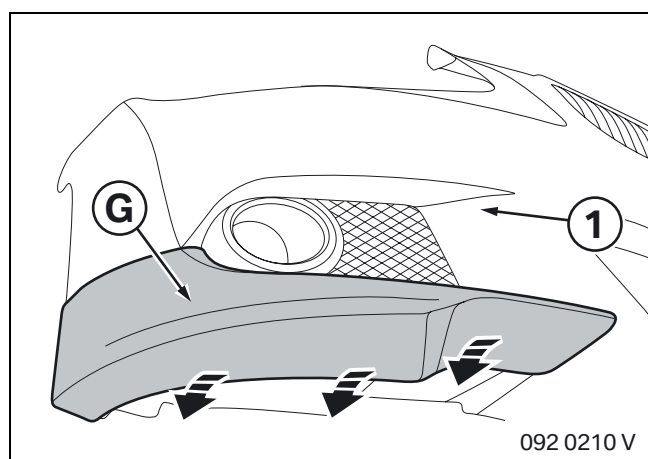

- ▶ Make sure that the fog lights, grille and painted areas of the front apron (1) are not damaged. ◀

Pull out front apron attachment **G** from below, turn upward and pull or break off.

Use hot-air blower and Betalink cleaner to remove all adhesive residue.

8. Concluding work and coding for E90 and E91

 The Betalink adhesive K1 requires at least 6 hours to harden at room temperature. After this period of time, remove the pieces of adhesive tape and screw on underride guard. Completely remove the marks made on the front apron.

The vehicles must not be driven through a car wash for at least 48 hours. ◀

9. Concluding work and coding for E92

 The Betalink adhesive K2 requires at least 4 hours to harden at room temperature. After this period of time, remove the pieces of adhesive tape and screw on underride guard. Completely remove the marks made on the front apron.

The vehicles must not be driven through a car wash for at least 48 hours. ◀