

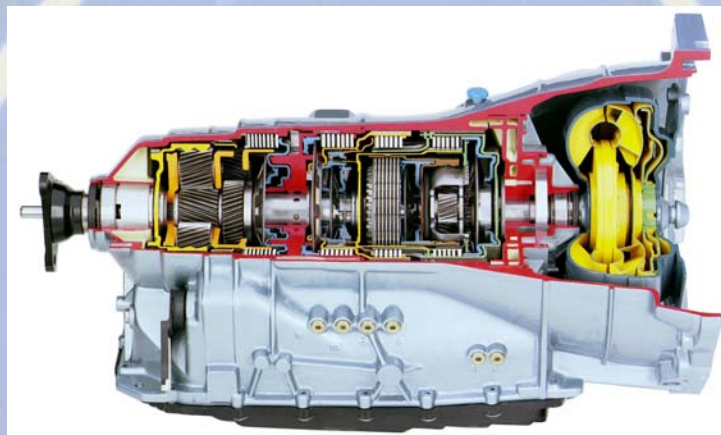

Functional Descriptions Automatic-Transmission



6HP19
6HP26
6HP32



Introduction / note

This brief technical description is intended to supply the necessary technical information on the components, construction and function of the automatic transmission.

Information status: **June 01**

For amendments and additions to the technical data, please refer to the latest Technical After-Sales Service information.

Reproduction, duplication or translation either wholly or in part are not permitted unless the authors' written permission has been obtained.

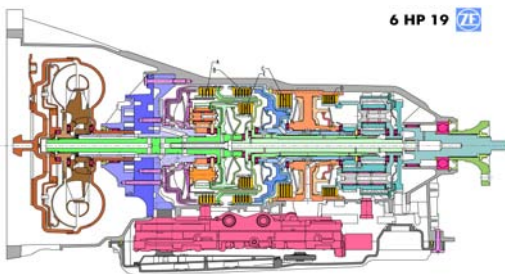

6HP19 automatic transmission



6HP26 automatic transmission



6HP32 automatic transmission

6HPxx Functional Description - Contents

Item	Page
Introduction / note	2
Contents	3
Coloured sectioned diagram - 6HP19	4
Key to coloured sectioned diagram - 6HP19	5
Brief description - general	6
Lepelletier planetary gear set	7
-- single-web planetary gear train	7
-- double planetary gear train	8
Description of individual components	11
-- Hydrodynamic torque converter (operating principle)	11
-- 6HP26 torque converter (sectioned diagram) without / with torsional vibration damper	12
-- Converter lock-up clutch (2 GWK + torsional vibration damper)	14
* Hydraulic flow in converter (lock-up clutch (WK) open)	15
* Hydraulic flow in converter (WK closed)	16
-- Oil pump	17
-- Shift elements	18
* Clutches / brakes / sectioned drawings	18
* Clutch - sectioned drawings	19
* Action of shift elements	20
-- Shift overlap control	21
-- Parking lock	22
* mechanical version	22
* electrical version	23
Transmission control area	25
-- Control elements and overview of shift system - E and M shift	25
-- Description of gears / power flow, 1st to 6th gear + Reverse	33
-- Hydraulic circuit diagram (DIN) (valve geometry, M / E shift)	49
-- Hydraulic and electronic (Mechatronik) control units	51
* General (ESD protection)	52
* Sectioned diagrams of individual components (M and E shift)	59
* Brief description of valves	69
* Description of solenoid valves, pressure regulator	71
* Position of pressure unions	72
* Threaded connections on components	76
* Electronic module (electronic control unit)	78
* Mechatronik block circuit diagrams	81
-- Technical data - 6HP19, 6HP26, 6HP32	85

6HP 19 automatic transmission

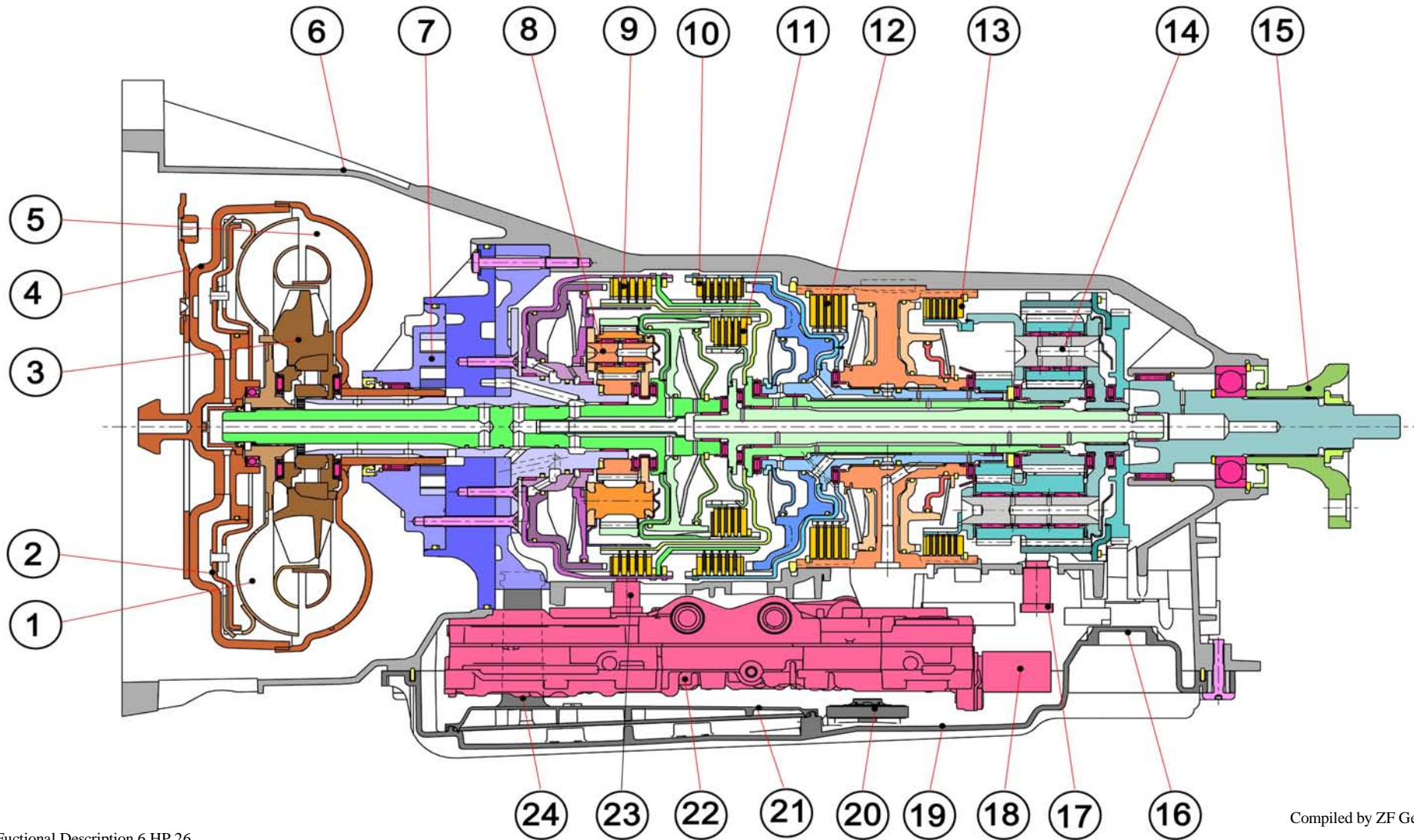

Key to coloured sectioned diagram 6HP19

- | | | | |
|----|---------------------------------|-----|--|
| 1 | Turbine | } | Torque converter |
| 2 | Converter lock-up clutch piston | | |
| 3 | Stator | | |
| 4 | Converter cover | | |
| 5 | Pump | | |
| 6 | Transmission housing | | (With integral converter dome and extension) |
| 7 | Oil pump | | (half-moon pump version) |
| 8 | Front single planetary gear set | | |
| 9 | Clutch | "A" | |
| 10 | Clutch | "B" | |
| 11 | Clutch | "E" | |
| 12 | Brake | "C" | |
| 13 | Brake | "D" | |
| 14 | Rear double planetary gear set | | |
| 15 | Output flange | | |
| 16 | Oil filler plug | | |
| 17 | Output speed sensor | | |
| 18 | Pressure regulating valves | | |
| 19 | Oil pan | | |
| 20 | Magnet | | |
| 21 | Oil mesh strainer | | |
| 22 | Hydraulic control unit | | (Mechatronik) |
| 23 | Turbine speed sensor | | |
| 24 | Suction pipe to oil strainer | | |

Brief description - general

The ZF 6HP26 automatic transmission has been developed for vehicles with an engine torque of up to 600 Newton-metres (Nm).

To match the installed position of the engine, the automatic transmission is also arranged longitudinally. It uses the planetary gear train principle, with hydraulic-electronic control; the hydraulic and electronic control units form a composite element that is installed as a single unit inside the automatic transmission and referred to as "Mechatronik".

A new feature is decoupling of the transmission when the vehicle is at a standstill, that is to say instead of the engine remaining connected to the converter and the vehicle being prevented from moving by applying the brake, the converter is disconnected and only a minimum rotating load remains. This has the effect of further reducing fuel consumption. The electronic transmission control uses a newly developed shift strategy known as "A S I S" (Adaptive Shift Strategy).

For this, please refer to the separate functional description.

The 6HP26 automatic transmission is about 13 % lighter than the previous 5-speed unit, accelerates 5 % faster and uses about 7 % less fuel.

It also contains fewer components:

- o 5-speed transmission app. 660 parts
- o 6-speed transmission app. 470 parts

The 6-speed automatic transmission is 5 centimetres shorter than the 5-speed transmission.

Engine power reaches the transmission via a hydrodynamic torque converter with integral converter lock-up clutch.

The input torque limits are:

6HP19	max. torque:	420 Nm
6HP26	max. torque:	600 Nm
6HP32	max. torque:	750 Nm

The 6 forward gears and 1 reverse gear are obtained from a single-web planetary gear set followed by a double planetary gear set.

Using these Lepelletier-type gear sets, it was possible to obtain 6 forward speeds.

The single-web planetary gear set consists of:

- 1 sunwheel
- 4 planetary gears meshing with it
- 1 planetary gear carrier
- 1 ring gear or annulus

The following double planetary gear set consists of:

- 2 sunwheels of different sizes
- 3 short planetary gears meshing with them
- 3 long planetary gears meshing with them
- 1 planetary gear carrier
- 1 ring gear or annulus

Single-web planetary gear set

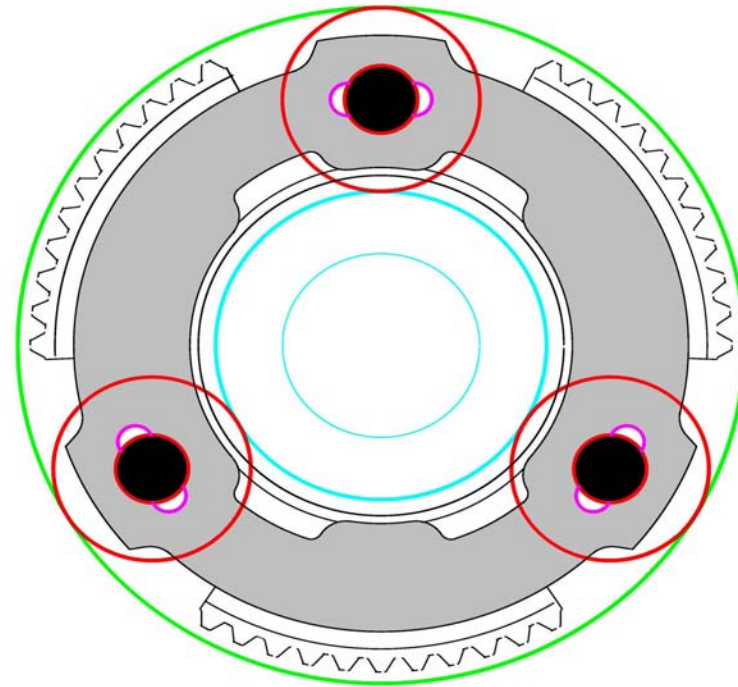
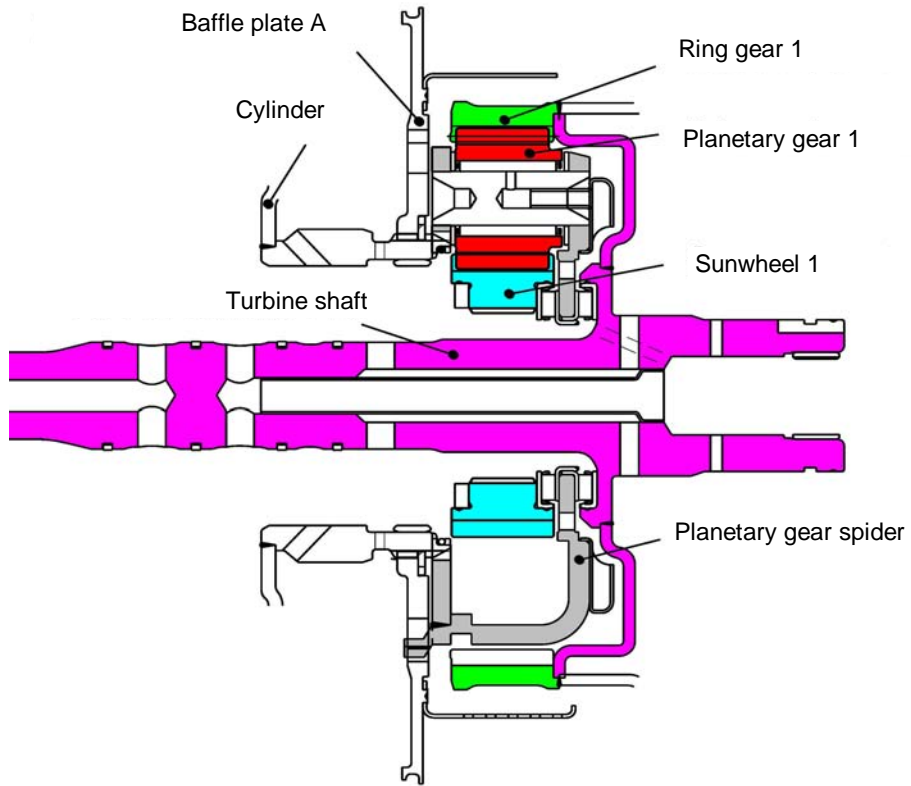

Rear double planetary gear set

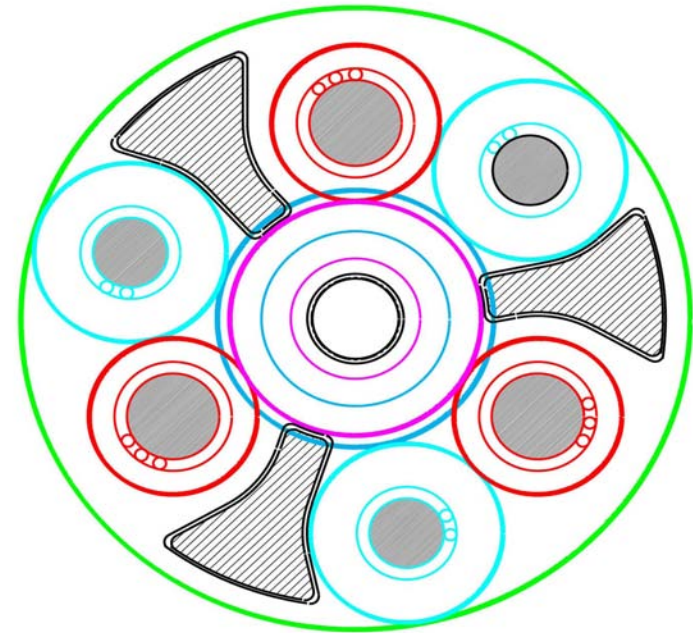
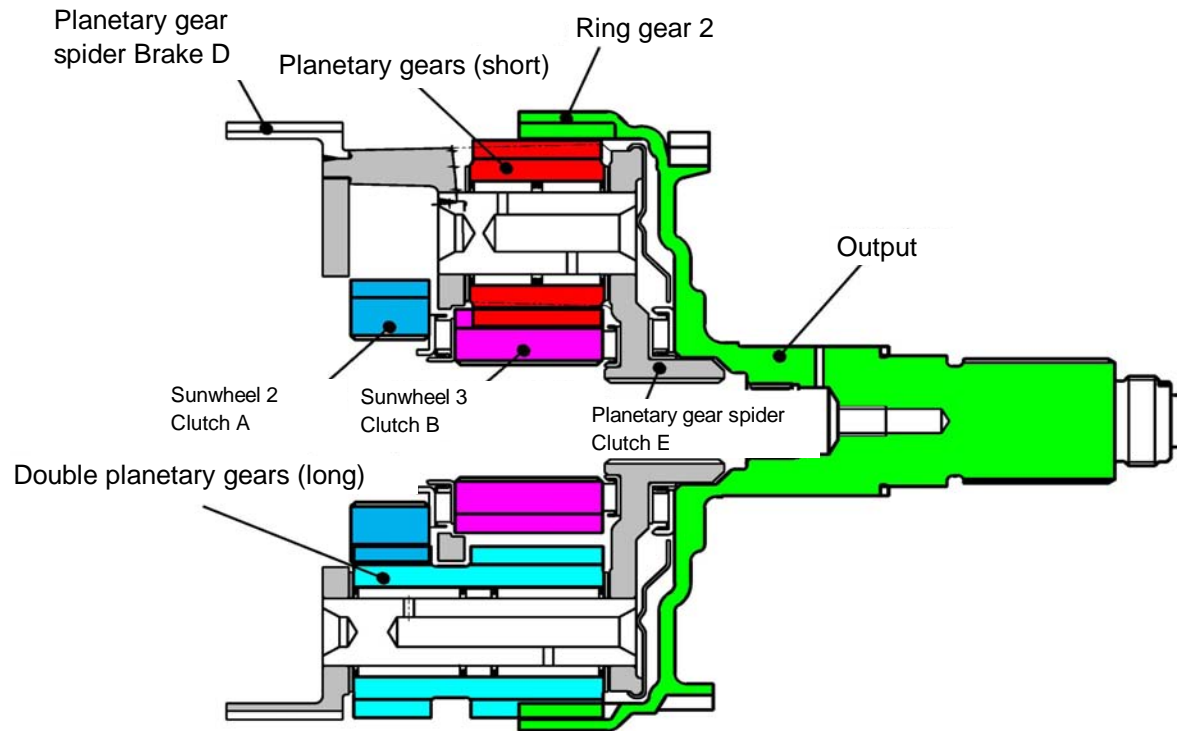

Single-web planetary gear set

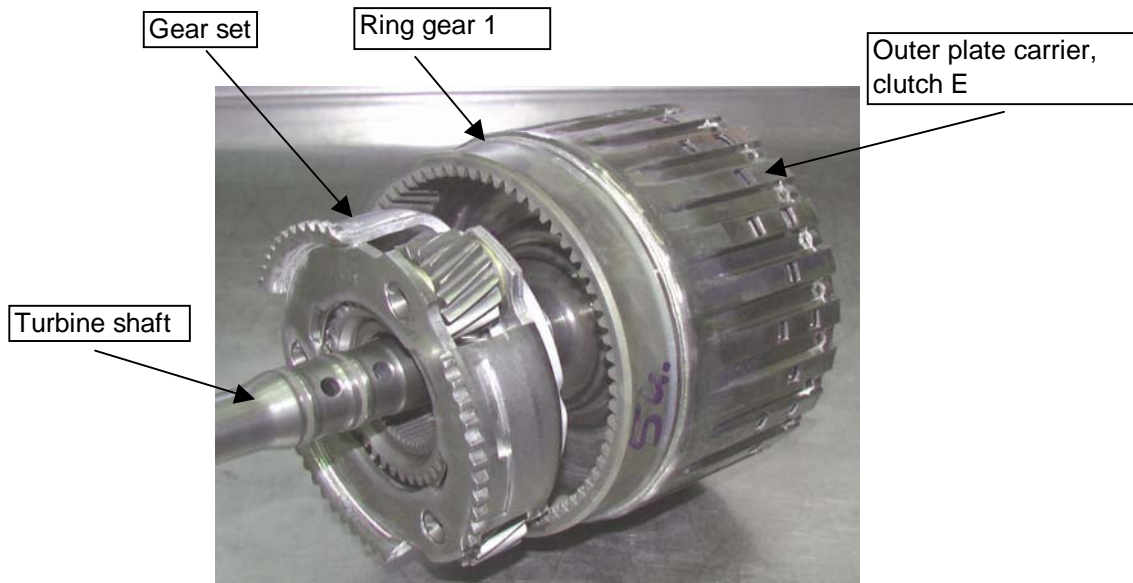

Rear double-web planetary gear set

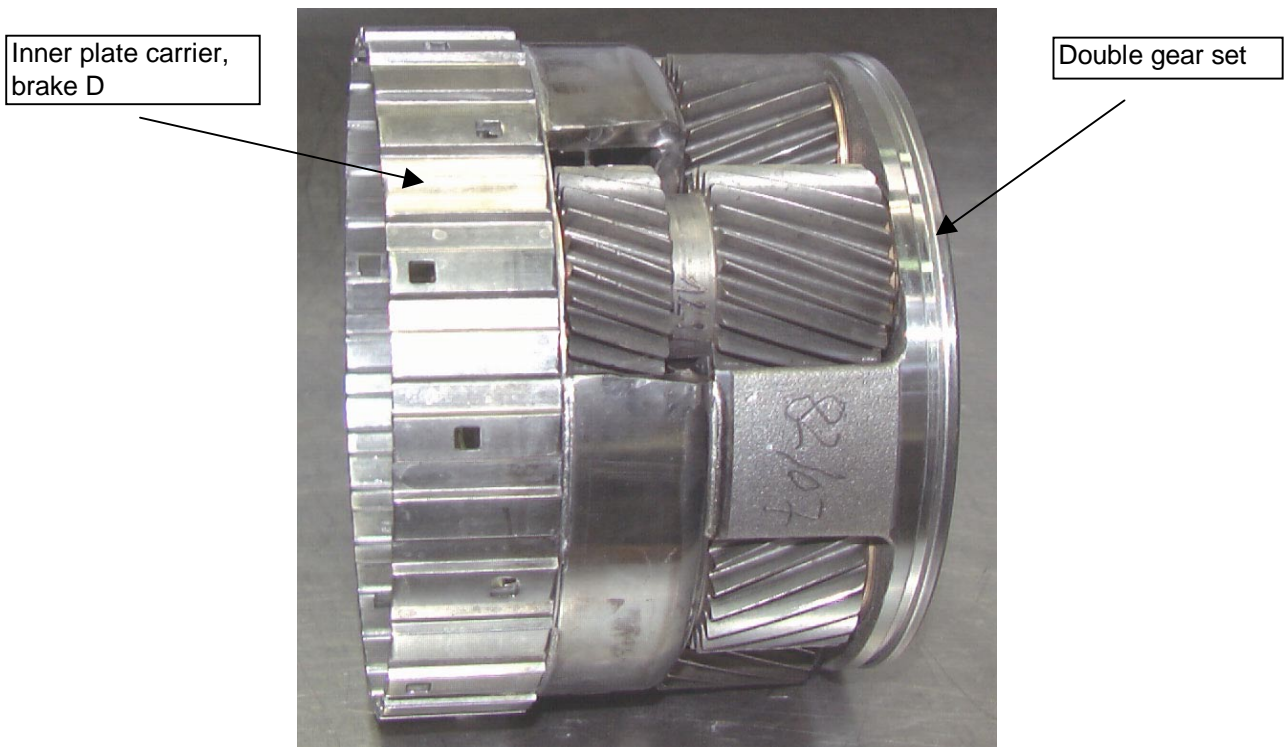

Gear ratios

The ratios for the various gears are obtained by diverting the incoming torque through various elements of the planetary gear train and braking other elements.

Output is always via the ring gear of the second, downstream planetary gear set.

See also description of power flow.

The mechanical gear ratios are:

Gear:	1st	2nd	3rd	4th	5th	6th	Rev.
Ratio:	4.171	2.340	1.521	1.143	0.867	0.691	3.403

Schematic diagram of 6HP26 / 6HP32 transmission

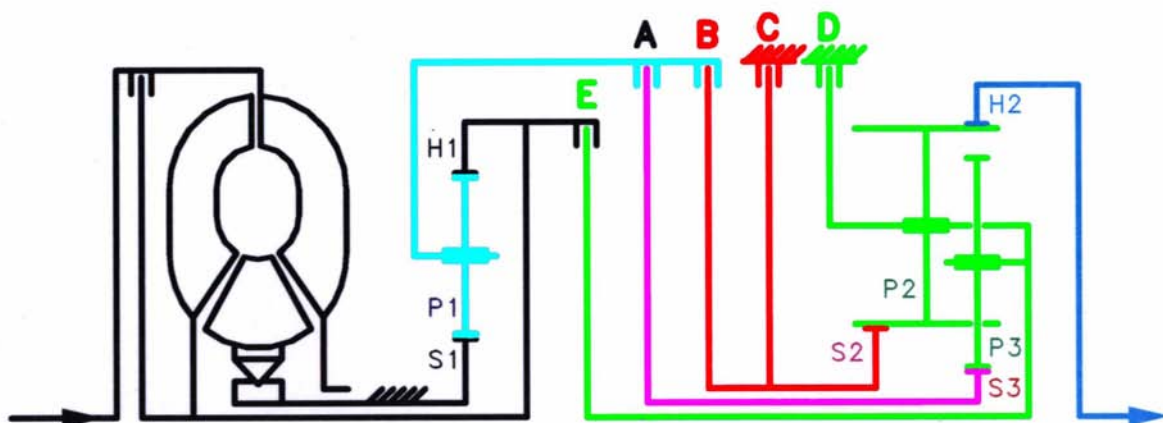

Description of individual components

The hydrodynamic torque converter

Converter operating principle

The torque converter consists of the impeller, the turbine wheel, the reaction element (stator) and the oil content needed to transmit the torque.

The impeller, which is driven by the engine, imparts a circular flow to the oil in the converter. This oil strikes the turbine wheel, which causes the flow to change its direction.

The oil flows out of the turbine wheel close to the hub and strikes the stator, where its direction is changed again to a direction suitable for re-entering the impeller.

The change in direction at the stator generates a torque reaction that increases the torque reaching the turbine.

The ratio between turbine and impeller torque is referred to as torque multiplication or conversion.

The greater the difference in speeds of rotation at the impeller and turbine, the greater the increase in torque; The maximum increase is obtained when the turbine wheel is stationary. As turbine wheel speed increases, the amount of torque multiplication gradually drops.

When the turbine wheel is rotating at about 85 % of the impeller speed, torque conversion reverts to 1, that is to say torque at the turbine wheel is no higher than at the impeller.

The stator, which is prevented from rotating backwards by a freewheel and the shaft in the transmission housing, runs freely in the oil flow and overruns the freewheel. From this point on, the converter acts only as a fluid coupling. During the torque conversion process, the stator ceases to rotate and bears against the housing via the freewheel.

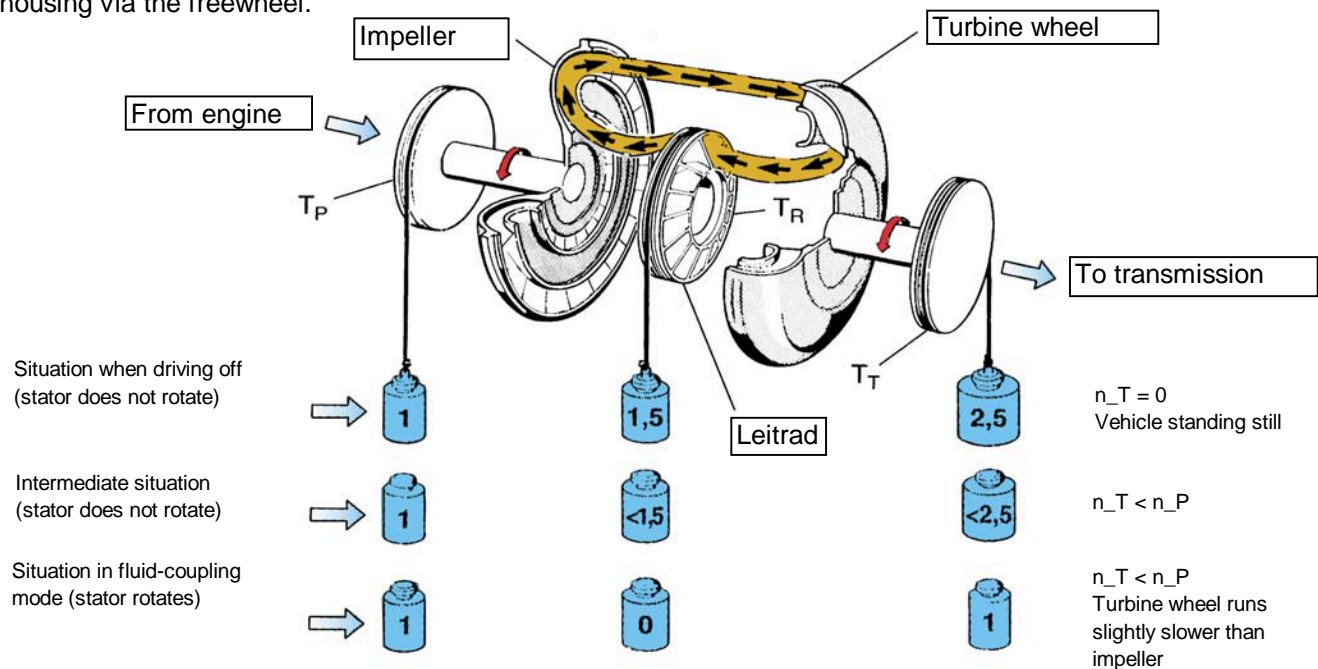

6HP26 - torque converter without torsional vibration damper

torque converter
W260 S - 2GWK

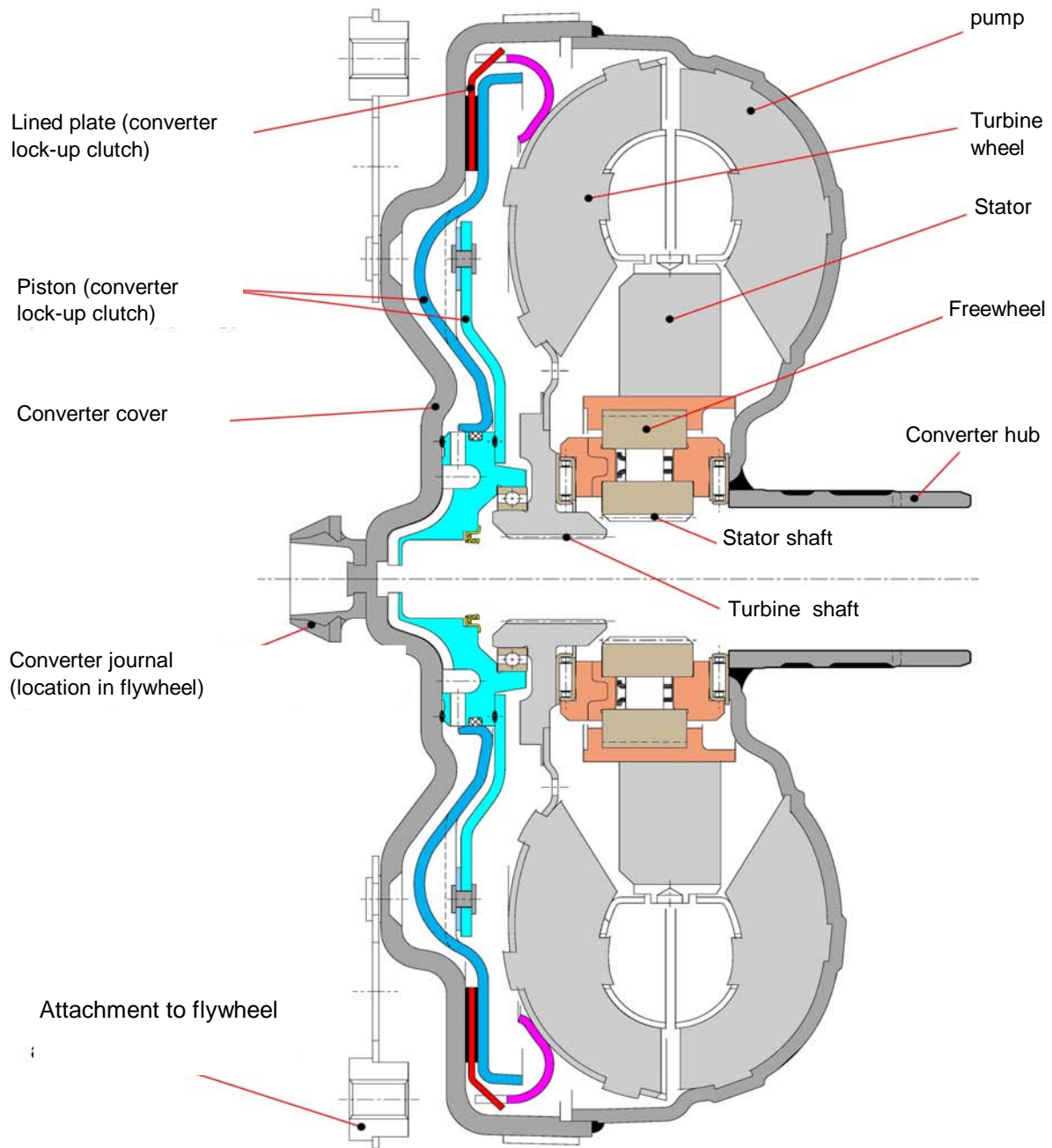

6HP26 torque converter with torsional vibration damper

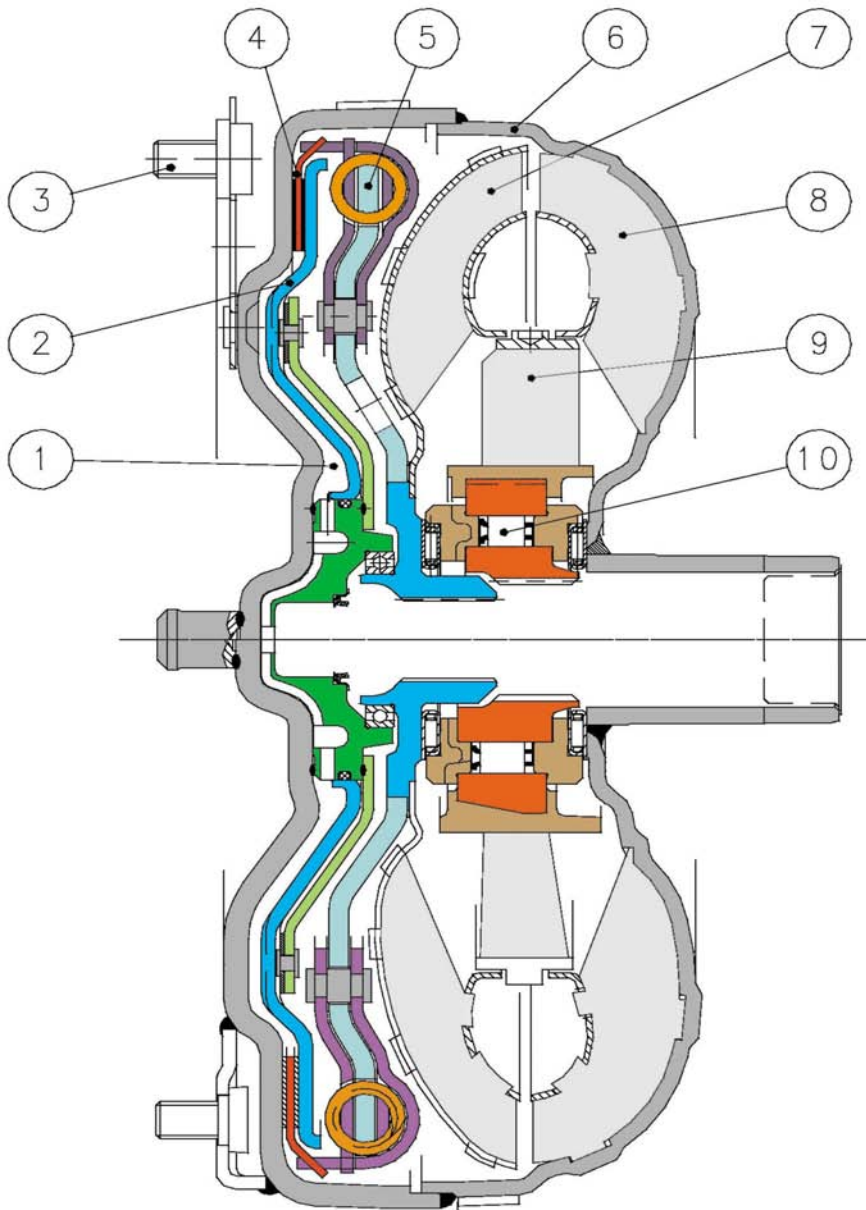

Upper half: W 260 S - 2 GWK / TD
 Lower half: W 280 S - 2 GWK / TD

- | | | | |
|---|-------------------------------|----|------------------|
| 1 | Space behind lock-up clutch | 6 | Converter cover |
| 2 | Lock-up clutch piston | 7 | Turbine |
| 3 | n_mot | 8 | Impeller |
| 4 | Lined plate of lock-up clutch | 9 | Stator |
| 5 | Torsional vibratiou damper | 10 | Stator freewheel |

Converter lock-up clutch

The converter lock-up clutch (WK) is a device that eliminates slip in the torque converter and therefore helps to keep fuel consumption to a minimum.

The WK is engaged and released by the control system. During the actuating phase, a slight difference is selected between the impeller and turbine wheels. This transmits vibration caused by engine rotation to the transmission, after it has been additionally suppressed by a torsional vibration damper.

This procedure ensures optimum shift quality and improves the noise pattern.

Pressure at the WK piston is determined by an electronic pressure control valve (EDS 6).

See also the oil flow diagram.

In accordance with the vehicle manufacturer's wishes, the lock-up clutch can be controlled and engaged in any gear from 1 to 6. The standstill decoupling facility is new. Instead of the engine continuing to drive the converter when the vehicle comes to a standstill (so that the foot has to be kept on the brake), the converter is disconnected from the driveline so that only a slight residual load remains. This further reduces fuel consumption. Decoupling is by actuating clutch A in the transmission, and is dependent on load and output speed.

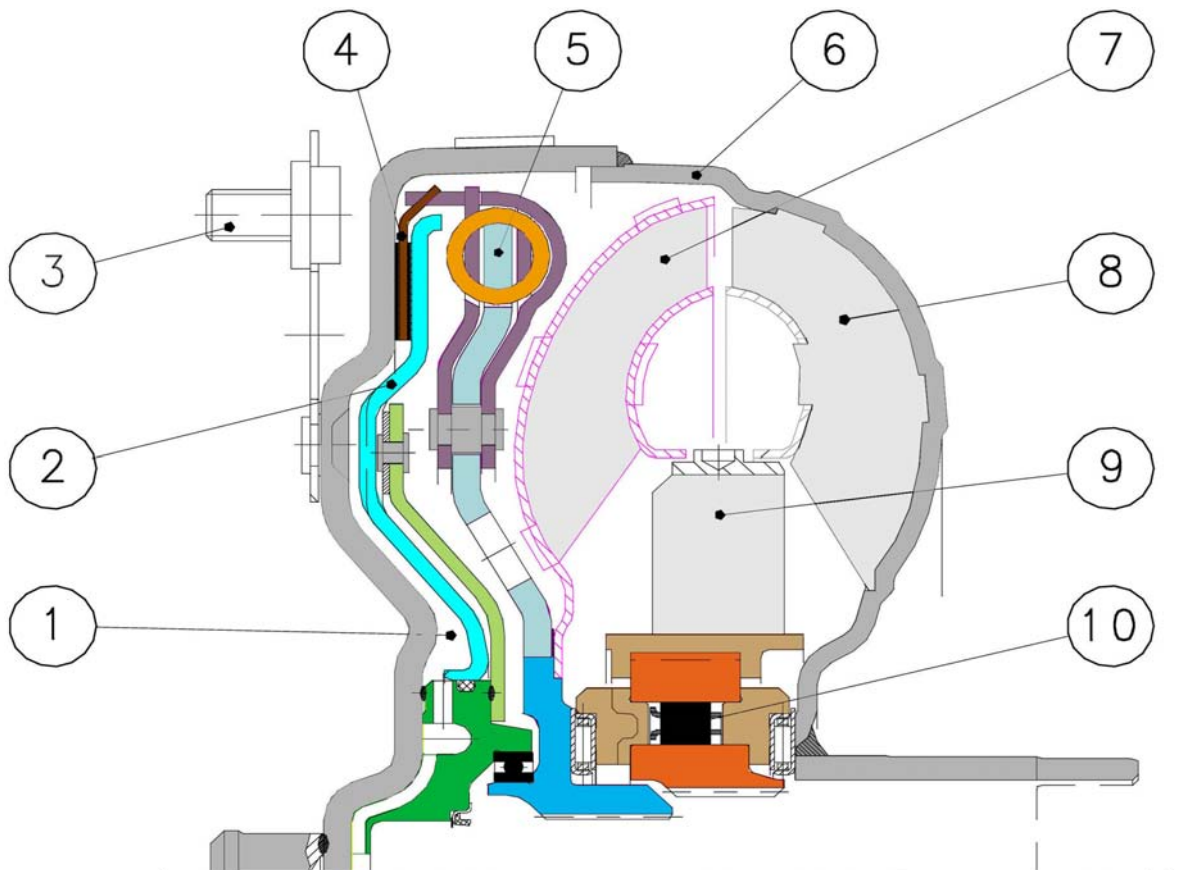

- | | | | |
|---|-------------------------------|----|------------------|
| 1 | Space behind lock-up clutch | 6 | Converter cover |
| 2 | Lock-up clutch piston | 7 | Turbine |
| 3 | n_mot | 8 | Impeller |
| 4 | Lined plate of lock-up clutch | 9 | Stator |
| 5 | Torsional vibration damper | 10 | Stator freewheel |

Hydraulic and mechanical flow in the converter

WK_auf **n_Mot > n_Turbine**

When released (conversion mode), oil pressures behind the lock-up clutch piston (1) and in the turbine area (2) are equalised. The direction of flow is through the turbine shaft and the area behind the piston into the turbine area.

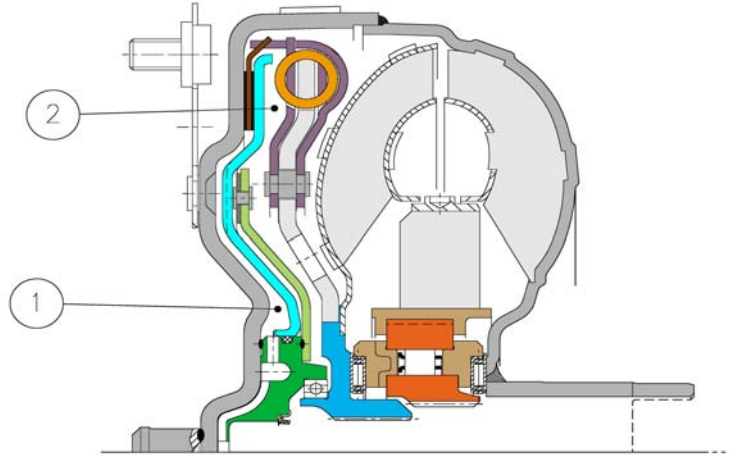

Oil flow, WK_released

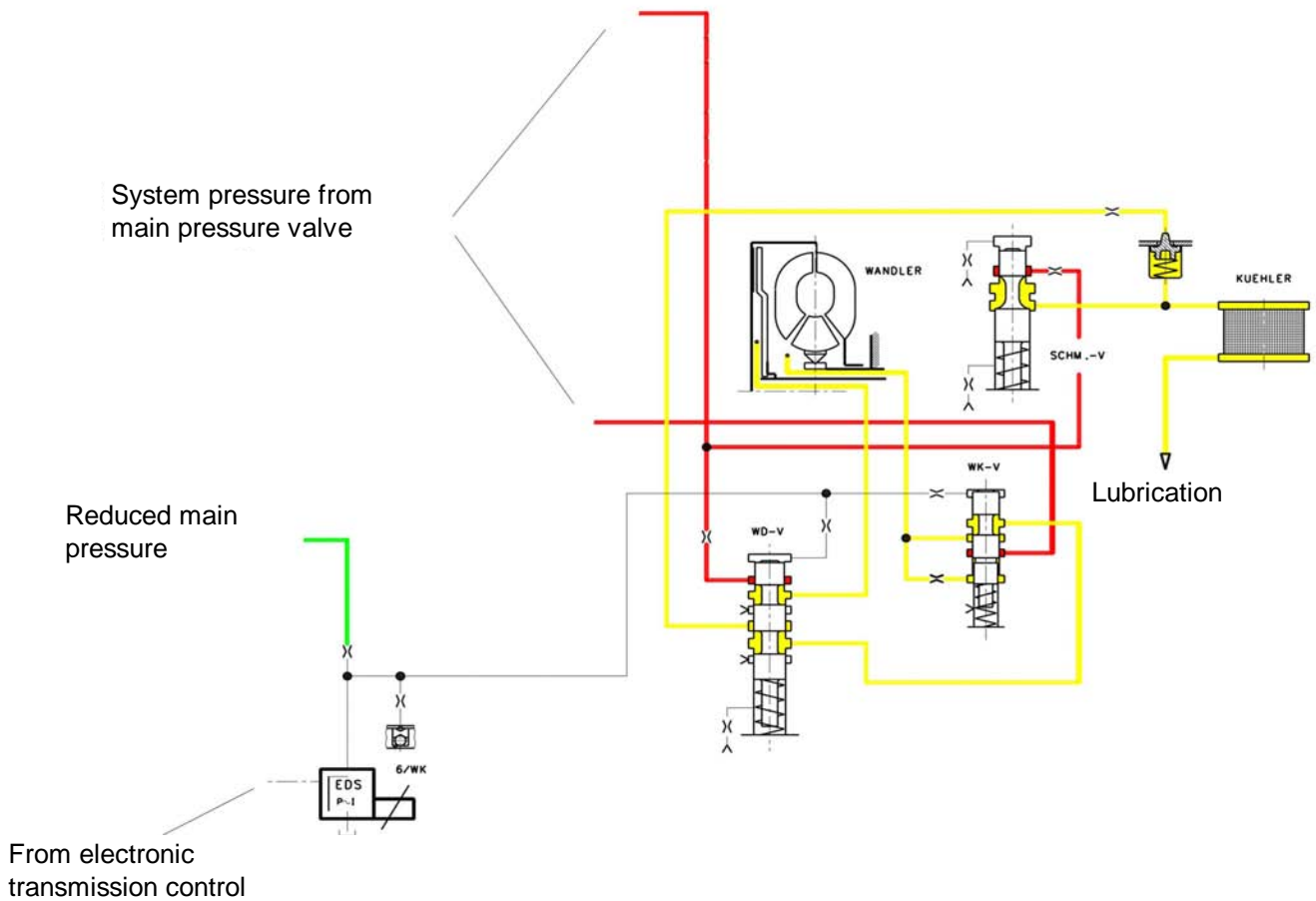

Hydraulic and mechanical flow in converter

WK_zu **n_Mot = n_Turbine**

To engage the lock-up clutch (4) the direction of oil flow is changed (reversed) by a valve in the hydraulic control unit. At the same time the space behind the lock-up clutch piston (1) is vented.

Oil pressure extends from the turbine area (3) to the lock-up clutch piston and presses it against cover (5) (outer shell of converter). This locks the turbine wheel (6) by way of the lined disc between the piston and the cover and enables the drive to pass either without slip or with limited slip to the planetary gear train in normal operating conditions.

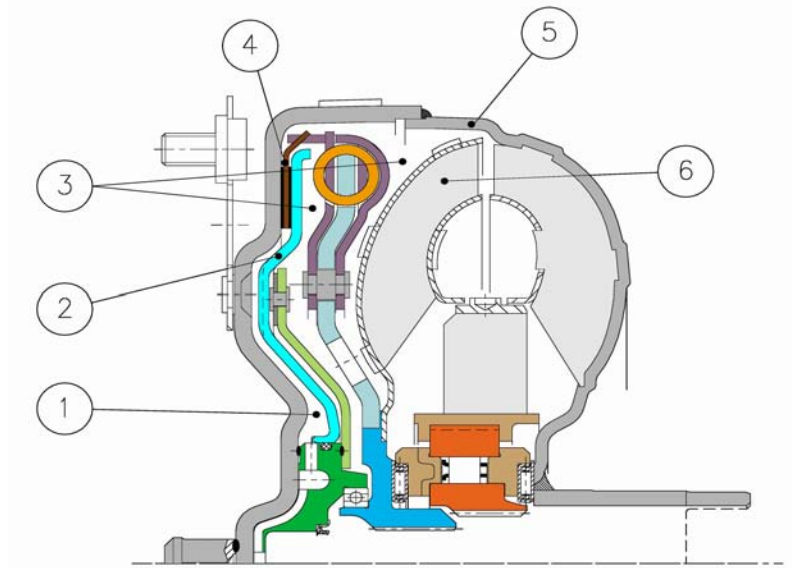

Oil flow WK_engaged

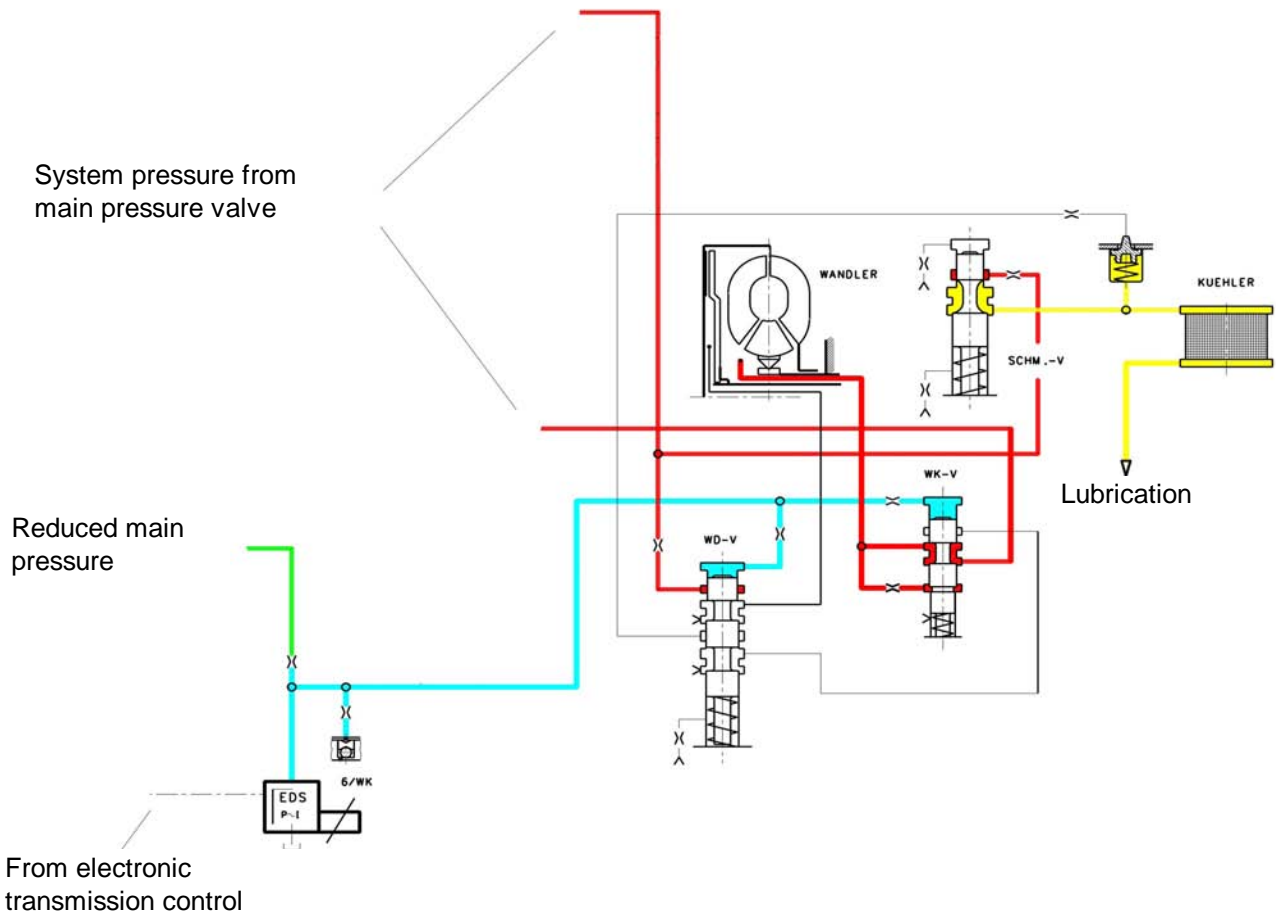

Oil pump (half-moon pump)

The oil pump is of "half-moon" pattern and delivers app. 16 sq. cm of oil per revolution. It is located between the torque converter and the transmission housing.

The converter is supported in the pump by a needle roller bearing. The pump is driven directly from the engine via the converter shell and supplies oil to the transmission and the hydraulic control unit.

The pump draws in oil through a filter and delivers it at high pressure to the main pressure valve in the hydraulic control unit. This valve adjusts the pressure and returns excess oil to the oil pan.

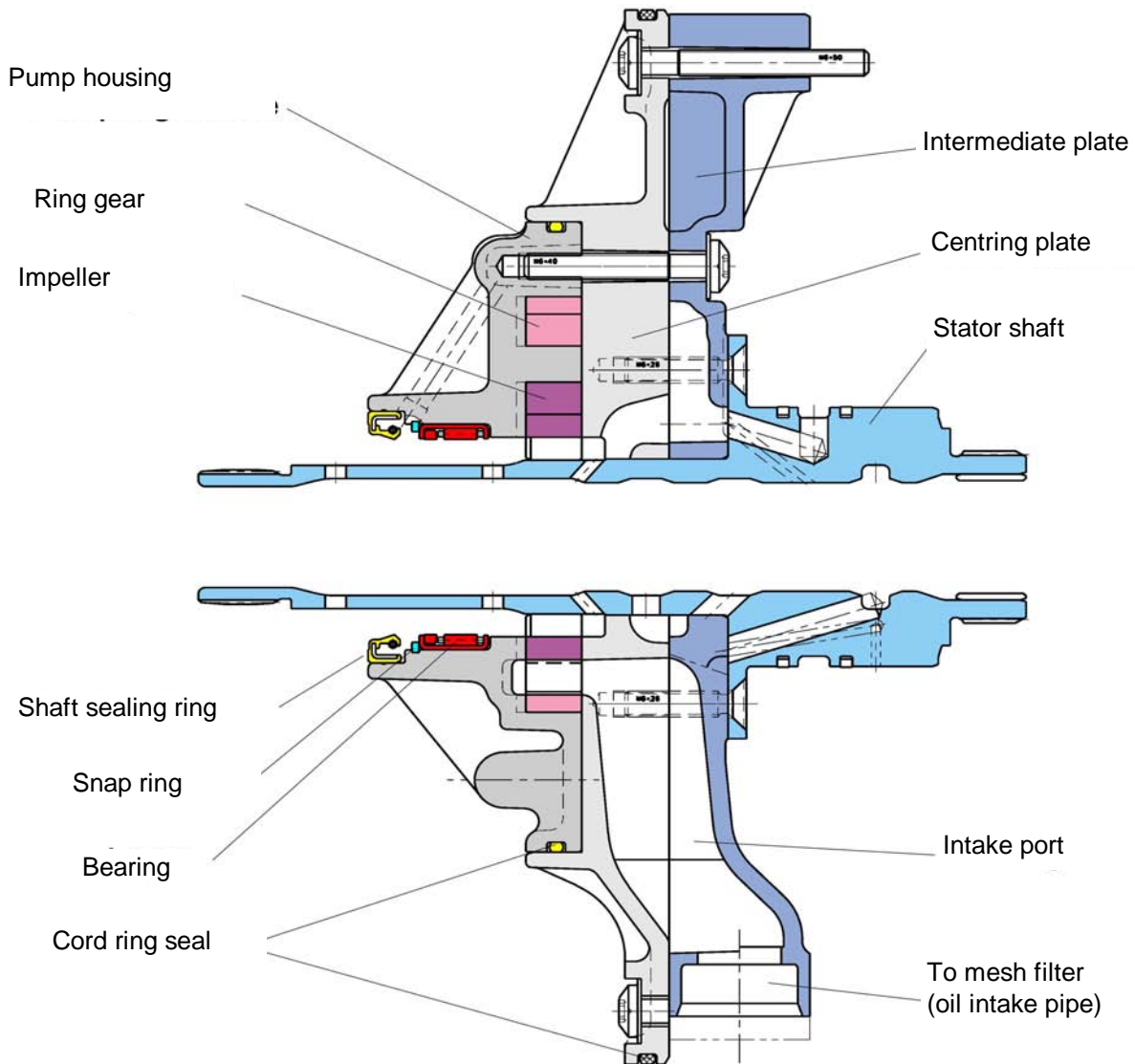

Shift elements

The other shift elements in addition to the converter lock-up clutch (WK) are:

- three rotating multi-plate clutches A, B and E
- two fixed multi-disc brakes C and D

All gear shifts from 1st to 6th or from 6th to 1st are power-on overlapping shifts, that is to say during the shift one of the clutches must continue to transmit the drive at lower main pressure until the other clutch is able to accept the input torque.

The shift elements, clutches or brakes are engaged hydraulically. The oil pressure is built up between the cylinder and the piston, thus pressing the clutch plates together.

When the oil pressure drops, the cup spring pressing against the piston moves it back to its original position.

The purpose of these shift elements is to perform in-load shifts with no interruption to traction.

Multi-plate clutches A, B and E supply power from the engine to the planetary gear train; multi-disc brakes C and D bear against the transmission housing in order to achieve a torque reaction effect.

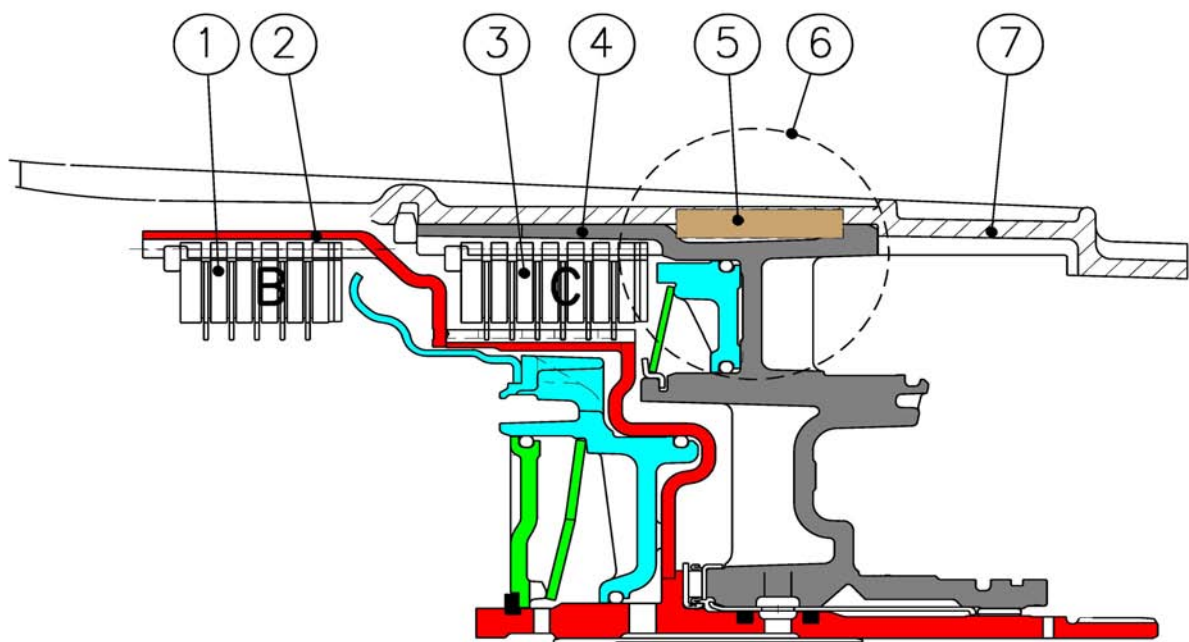

- | | |
|--|--|
| 1 Multi-plate clutch B | 5 Shaft key |
| 2 Clutch cylinder B, outer plate carrier | 6 Brake cylinder C, outer plate carrier (bears against transmission housing) |
| 3 Multi-disc brake C | 7 Transmission housing |
| 4 Brake cylinder C, outer plate carrier | |

Example of multi-plate clutch (clutch E)

Clutch E is equalised in terms of dynamic pressure, that is to say its piston is exposed to the oil flow on both sides, in order to prevent pressure build up in the clutch as the speed increases. This equalisation process is achieved by baffle plate (1) and pressure-free oil supply via lubricating passage (2), through which the space between piston and baffle plate is filled with oil.

The advantages of this dynamic pressure equalisation are:

- reliable clutch engagement and release in all speed ranges
- improved shift refinement

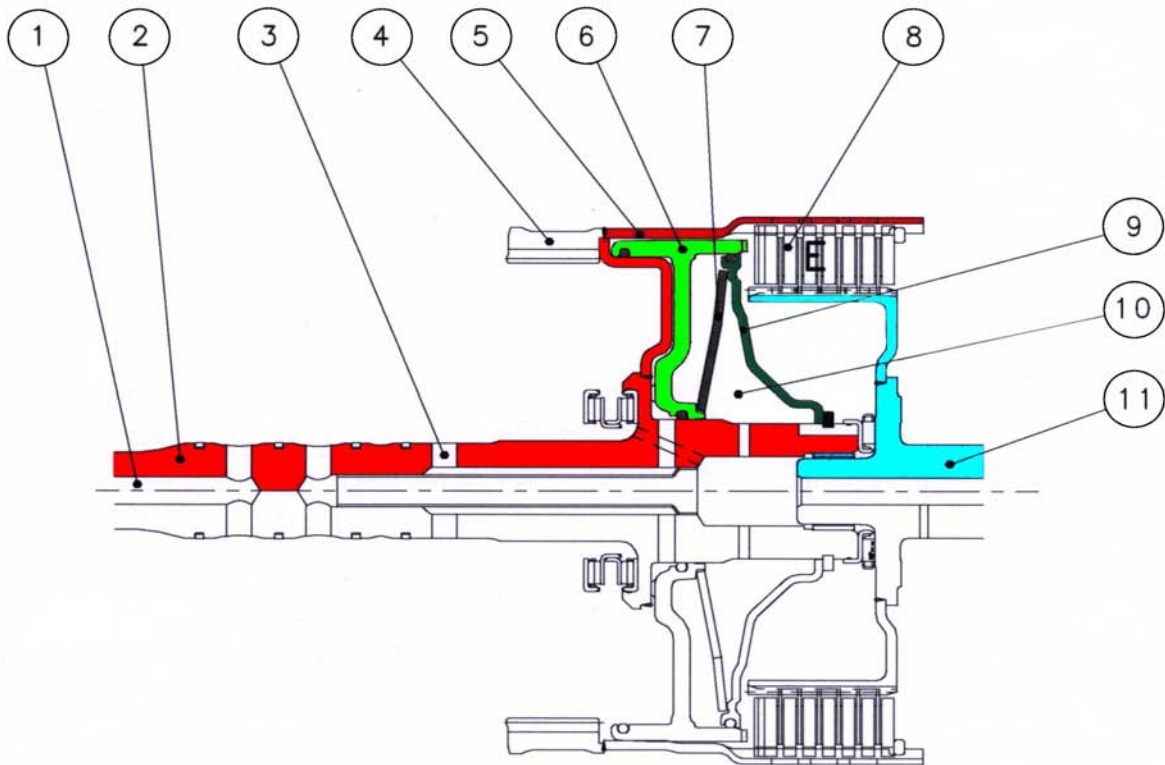

- | | |
|--|---|
| <p>1 Lubricating oil passage</p> <p>2 Turbine shaft</p> <p>3 Main pressure supply to clutch E</p> <p>4 Ring gear, planetary gear set 1</p> <p>5 Cylinder E (outer plate carrier)</p> <p>6 Piston E</p> | <p>7 Cup spring</p> <p>8 Clutch plate cluster</p> <p>9 Baffle plate</p> <p>10 Space for dynamic pressure equalisation</p> <p>11 Inner plate carrier E</p> <p>12 Space between piston and cylinder</p> |
|--|---|

Action of shift elements

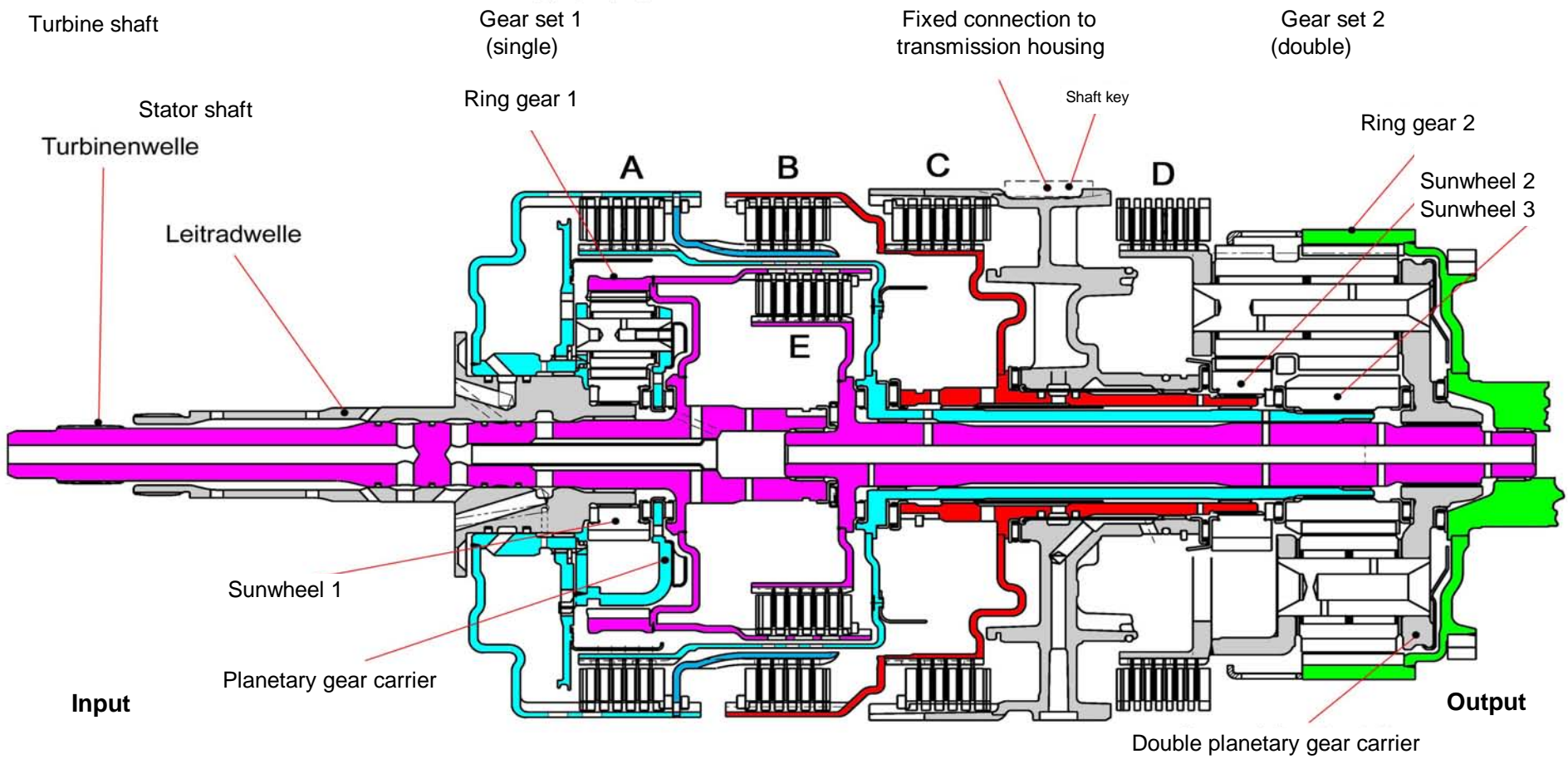

Shift overlap control

When overlap gear shifts take place, freewheels are not used but are replaced by suitable actuation of the relevant clutches (electronic-hydraulically). This enables both weight and space to be saved. The electronic-hydraulic shift action is obtained by means of various valves in the hydraulic control unit, actuated by pressure regulators. They engage or disengage the relevant clutches or brakes at the correct moments. The electronic control unit is combined with the hydraulic control unit and installed as a single unit in the transmission (Mechatronik).

Schematic diagram of shift overlap control

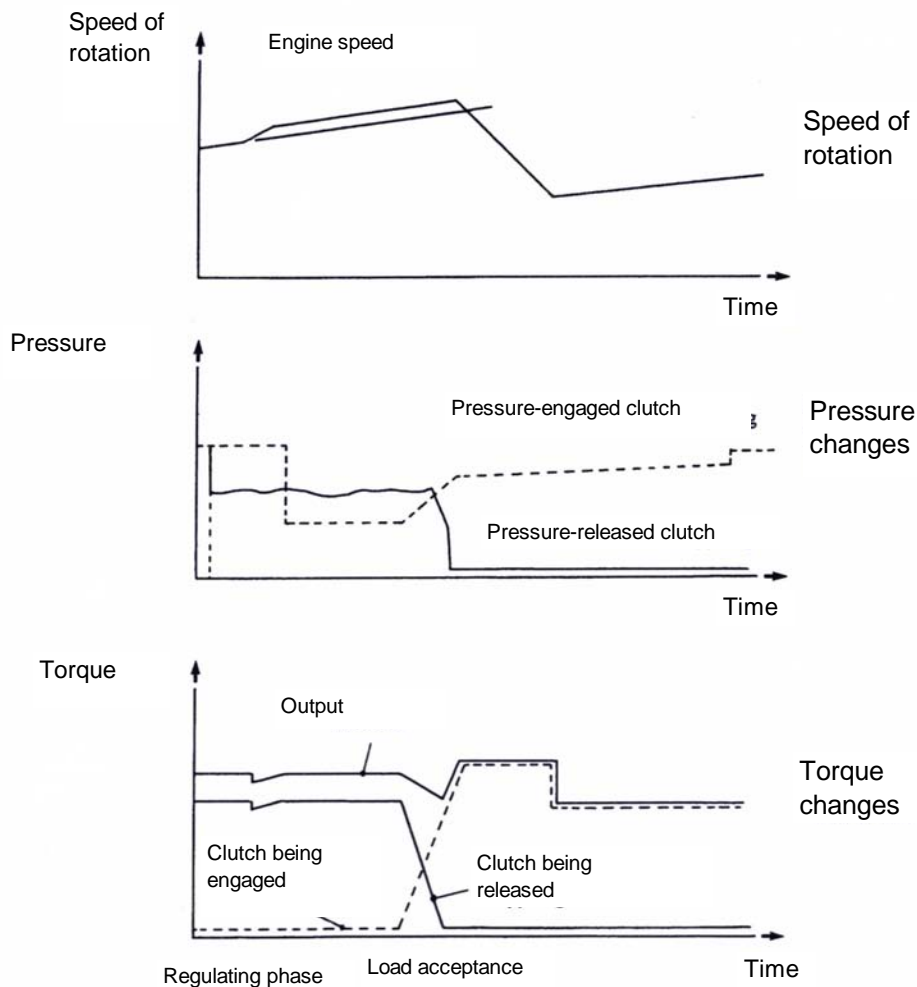

Parking lock

General:

The parking lock is a device that prevents the vehicle from rolling away out of control. It is engaged when the vehicle is standing still, either purely mechanically or electrically depending on the transmission version.

The mechanical version uses a wire cable from the selector lever unit in the vehicle to the transmission.

The electrical version is engaged by a steering-wheel pushbutton (on the SZL = steering-wheel switching centre) with a cable leading to the transmission.

The parking lock mechanism inside the transmission is as in previous versions.

The parking lock acts by inserting a pawl into the teeth of the parking lock gearwheel on the transmission output shaft; this prevents the rear wheels from turning by way of the propeller shaft and rear-axle final drive.

1.) Mechanical version:

On the purely mechanical version, the parking lock is engaged at the vehicle's selector lever, which is connected by a wire cable to the detent disc in the transmission.

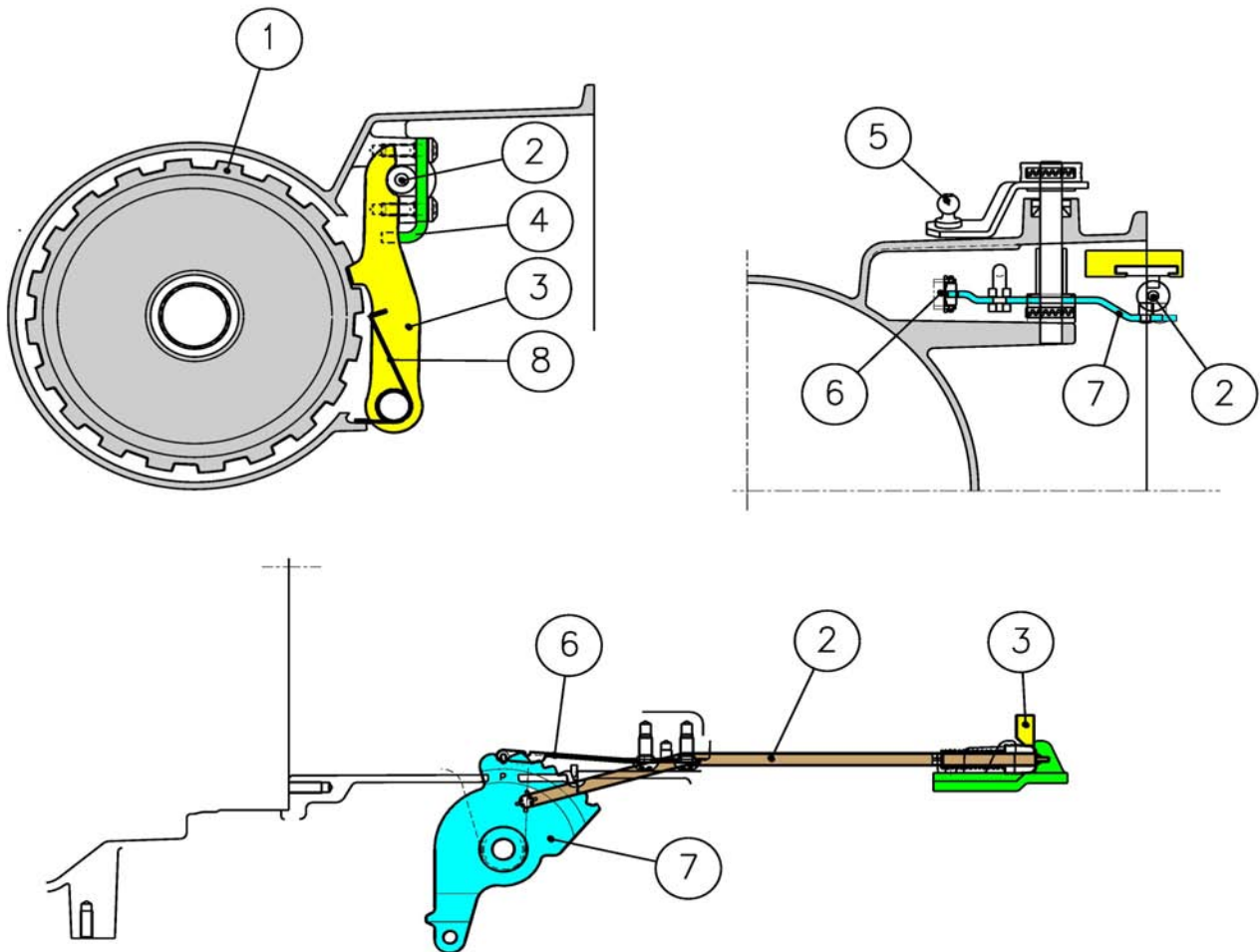

- 1 Parking lock gearwheel
- 2 Connecting rod
- 3 Parking lock pawl
- 4 Guide plate

- 5 Selector lever (gear shift lever)
- 6 Detent spring
- 7 Detent disc
- 8 Torsion spring

2.) Electrical version:

On the electrical version, the parking lock is engaged by a mechanical spring system in the transmission and secured electrically. All drive positions are also selected electrically. The detent disc in the transmission is omitted, and replaced by a parking disc and lock cylinder with solenoid valve (MV3).

The parking lock is actuated by way of the position switch (hall-effect sensor) on the e-module.

Function:

When the park position is deselected, MV2 resets the parking lock valve in the hydraulic control unit. The main pressure that is present there reaches the parking lock cylinder and pushes the piston back to release the lock.

MV3 is energised and locks the piston additionally by means of the ball catches.

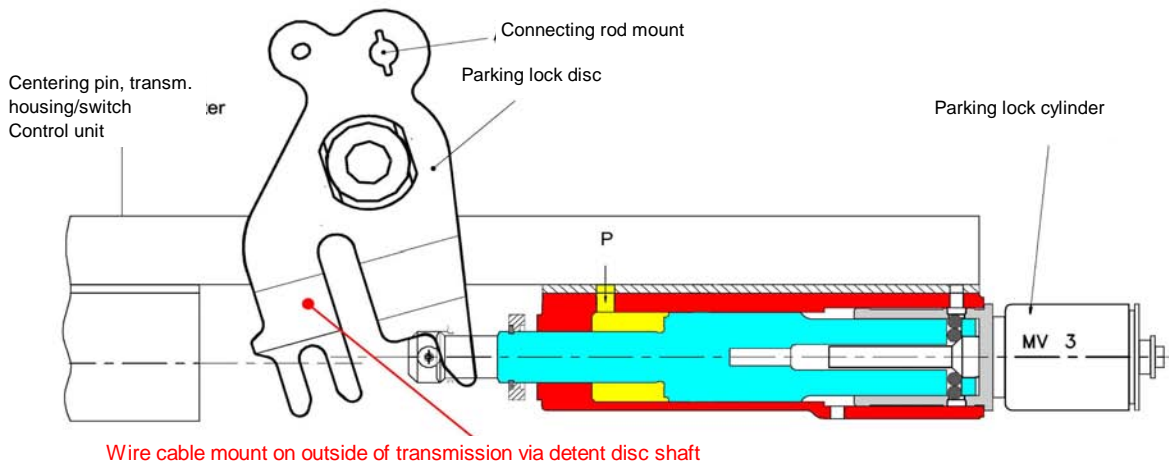

When the park position is selected, MV3 is de-energised. The mechanical piston lock at the ball catches is released and the piston is able to move.

In this situation, MV2 is also de-energised. The parking lock valve returns to its rest position and vents the parking lock cylinder. The pre-tensioned torsion spring at the parking lock disc pulls the piston in the "park" direction and engages the parking lock.

An additional wire cable at the parking lock disc can be used to release the parking lock manually in certain situations (for instance an electrical failure in the emergency program).

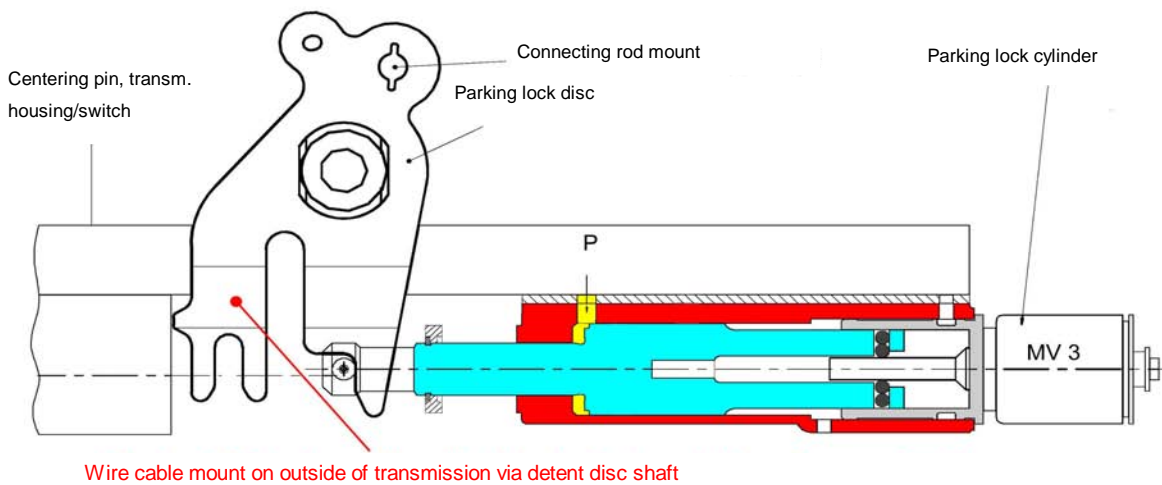

Parking lock operating elements

The wire cable or linkage to the selector gate inside the vehicle is supplied by the vehicle manufacturer.

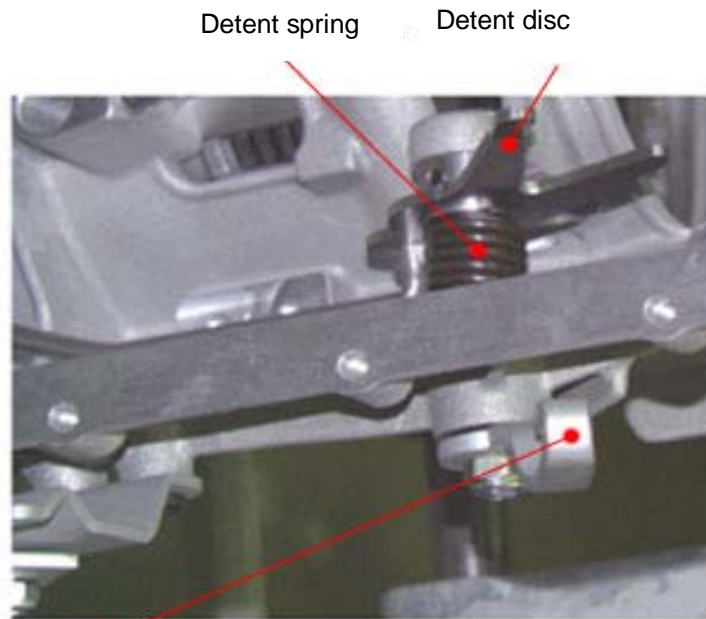

Selector lever:
Connecting wire cable for emergency release with E shift
Connecting wire cable to shift gate with M shift.

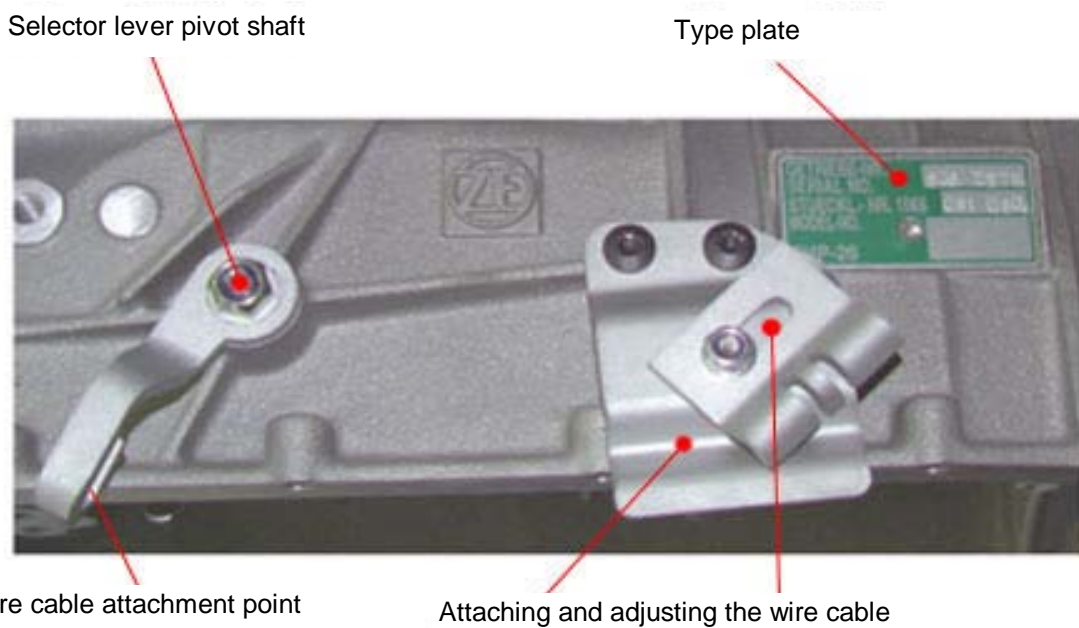

Transmission control area - BMW

Controls and gear shift display

There are various forms of control available for the 6-speed automatic transmissions. They are as specified by individual customers and either electrically or mechanically operated. The selector lever can be either on the centre console or on the steering column.

1. Mechanical shift (BMW wiring)

- * Automatic transmission with Mechatronik
- * Digital Motor / Diesel Electronics (DME / DDE)
- * Car Access System (CAS) - a development of the electronic immobiliser (EWS)
- * With Steptronic, selector lever on centre console

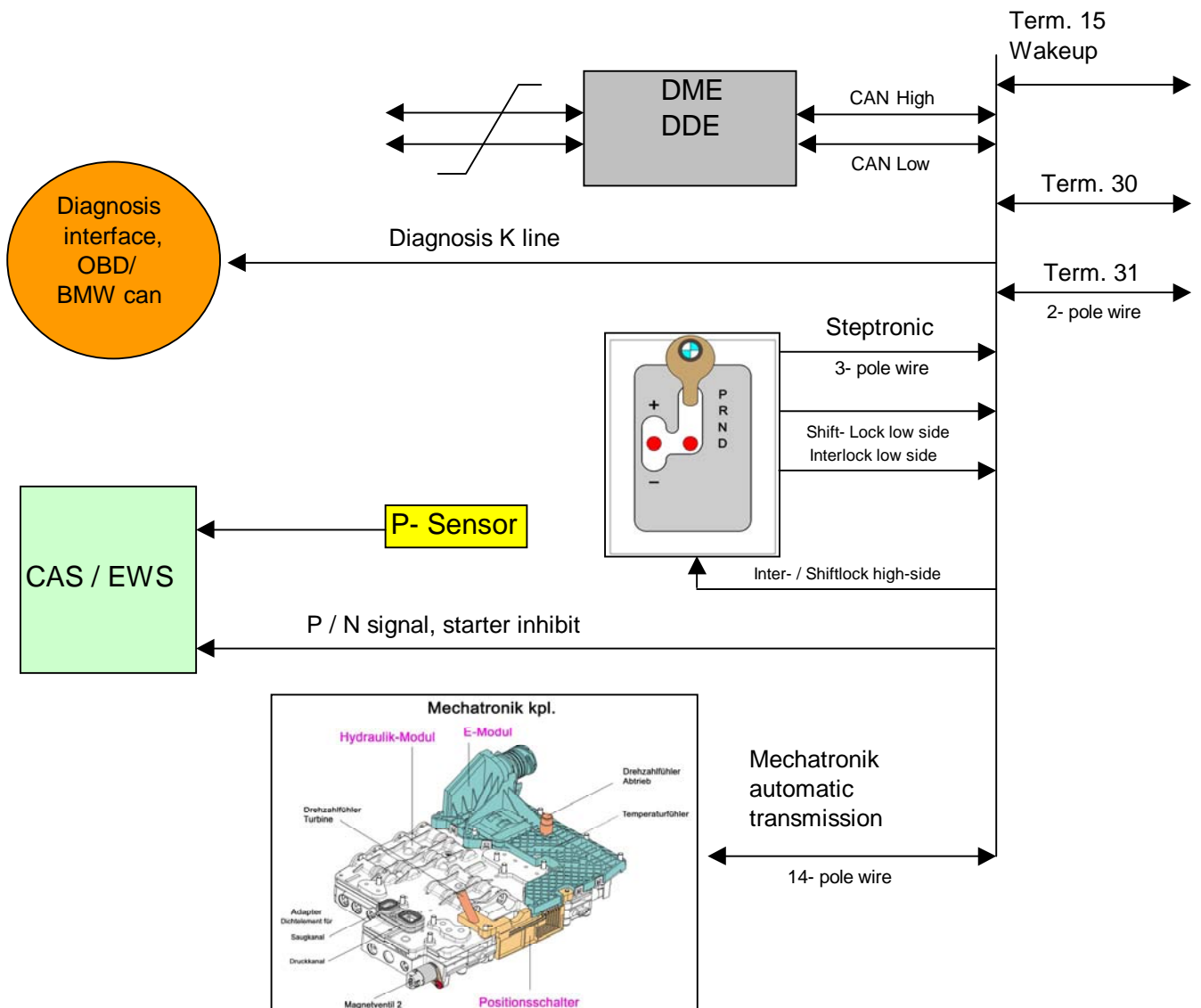

Selector lever positions (location on centre console)

The selector can be used to obtain the following gears mechanically.

Position / function

P = Park. Select only when vehicle is standing still.

Correct procedure:

First apply the handbrake, then select position P.

R = Reverse. Select only with the vehicle at a standstill and the engine idling.

N = Neutral. With the car standing still, apply the handbrake as well to prevent it from creeping forward. During the journey, only select neutral in an emergency situation in order to avoid a skid.

D = Drive. Automatic gear selection for forward travel in regular driving conditions. Shifts are automatic between 1 - 6 / 6 - 1. To select specific gears, see "Tip" mode (M program).

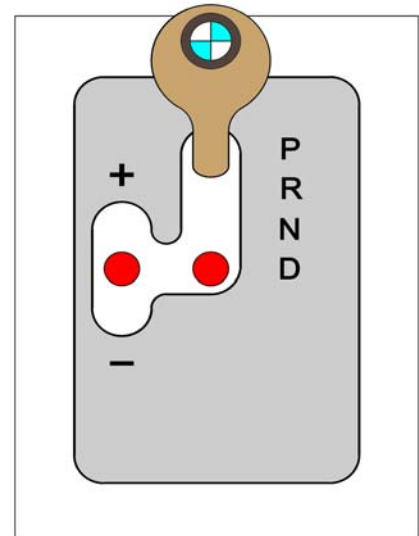

Program selection:

The various programs are selected according to the position of the lever in the gate.

Three basic programs are available:

- | | | |
|----------------------------|---|--|
| Blue, position (D) | = | XE program (Adaptive Transmission Control AGS) |
| Yellow, position (S) | = | S program (Adaptive Transmission Control AGS) |
| Yellow, acc. to (+) or (-) | = | Tip mode (manual selection) |

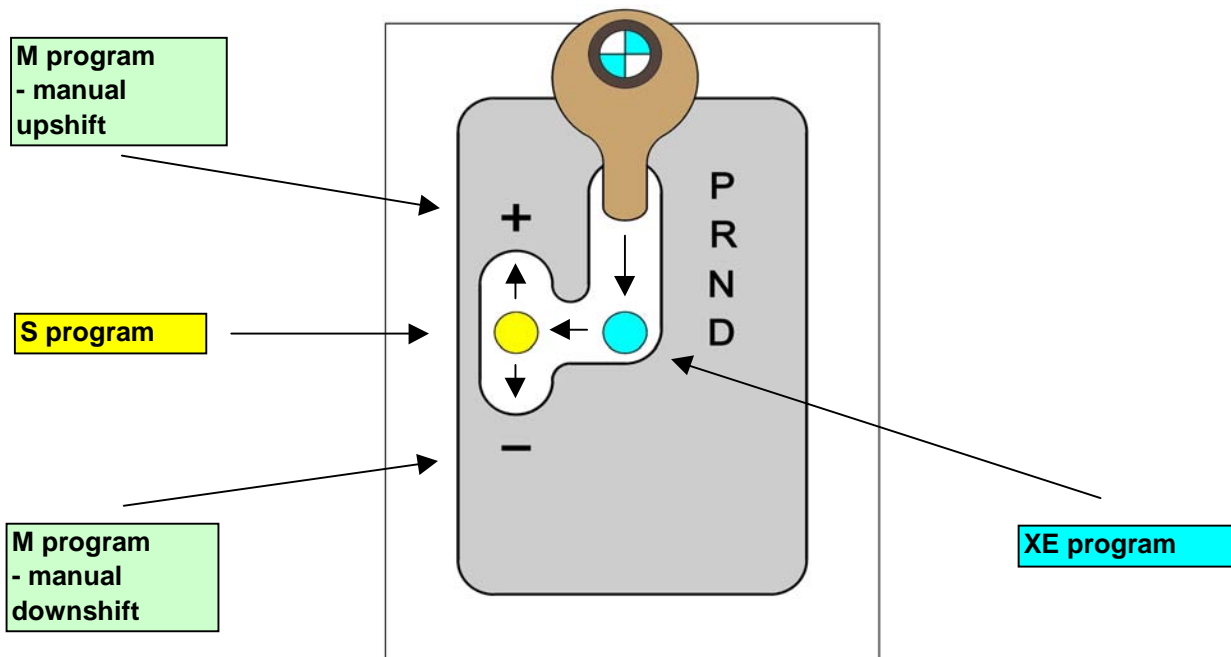

XE program (AGS)

Standard drive program in position D

The adaptive transmission control includes various driving programs, for example:

- Towing a trailer
- Hillclimb and descent
- Freeway (constant speeds)
- City driving
- Twisting roads etc.

These are selected automatically according to resistance to movement, load and accelerator pedal movement speed; depending on the driving situation, various shift characteristics are made available.

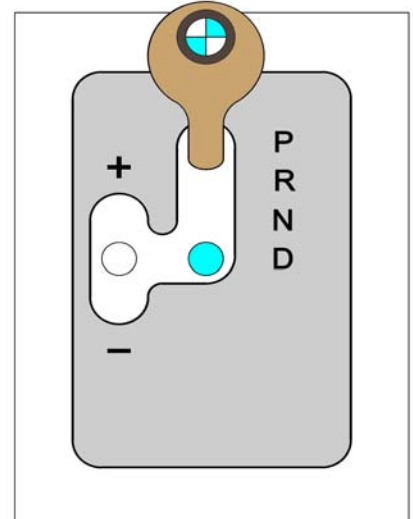

S program (Sport program)

The S program is a performance-oriented program, in which the shift characteristics are moved up to higher engine speeds. The program is selected by moving the selector lever across to the left gate plane **but without moving it to (+) or (-)**.

Gears 1 - 6 and 6 - 1 are selected automatically.

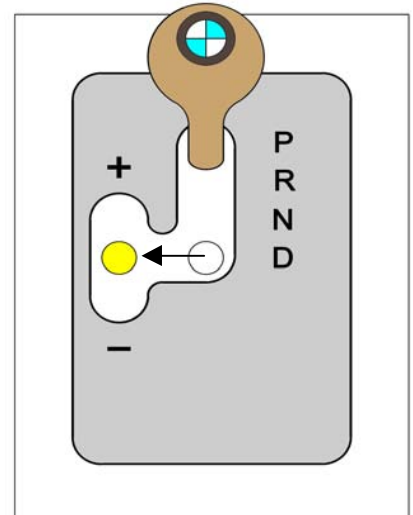

M program (Tip mode) - manual selection

The M program is a manual selection program activated when the lever is moved to the left gate plane and then to either (+) or (-).

The car can be driven off in gears 1 - 3.

4th gear can be selected manually from app. 10 km/h,
5th gear can be selected manually from app. 35 km/h and
6th gear can be selected manually from app. 45 km/h.

Each movement to (+) causes a one-gear up-shift.
Each movement to (-) causes a one-gear downshift.

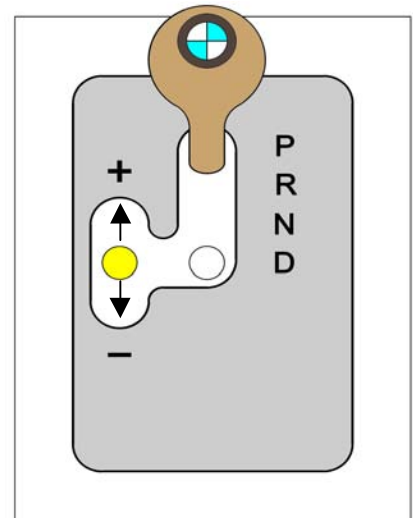

Controls and shift details

2. Electric shift (BMW overview)

The system overview below describes the principal components of the electric shift.

- * Transmission with EGS (Mechatronik)
- * Selector lever on steering column with SZL (switching centre)
- * Instrument cluster
- * Emergency mechanical release



The driver's gear shift requirement is obtained as an electrical signal from the selector lever or the buttons on the multi-functional steering wheel, and transmitted by SZL via the CAN and a redundant serial line to the transmission control unit (EGS). In the transmission the commands are implemented after taking various peripheral conditions into account. The selected gear is displayed on the instrument cluster. The parking lock is controlled electrically and activated when the ignition key is removed.

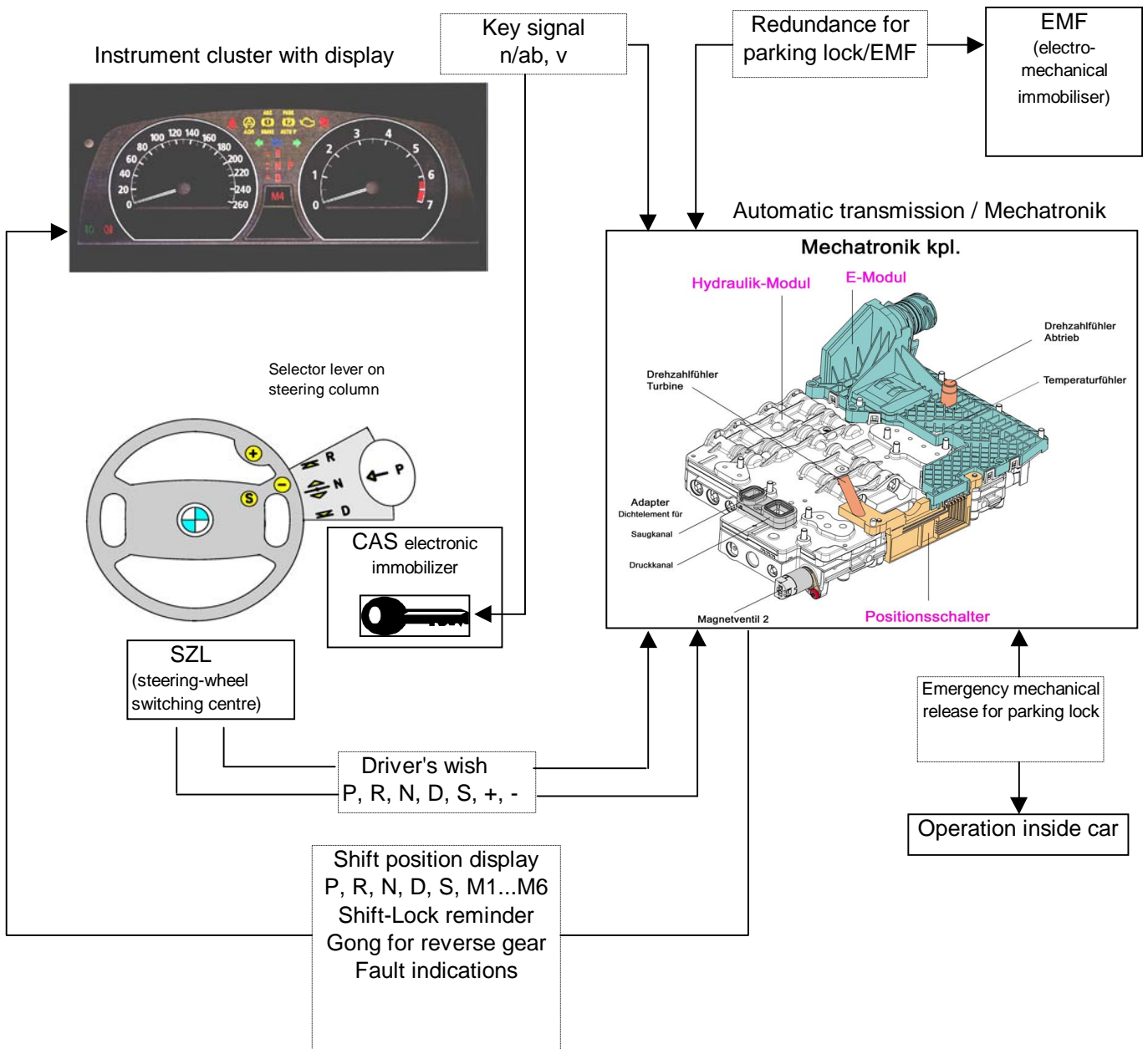

Controls and shift details

3. Electric shift (BMW wiring)

- * Transmission with EGS (Mechatronik)
- * Selector lever on steering column with SZL (steering column switching centre)
- * Car Access System CAS (development of EWS electronic immobiliser)

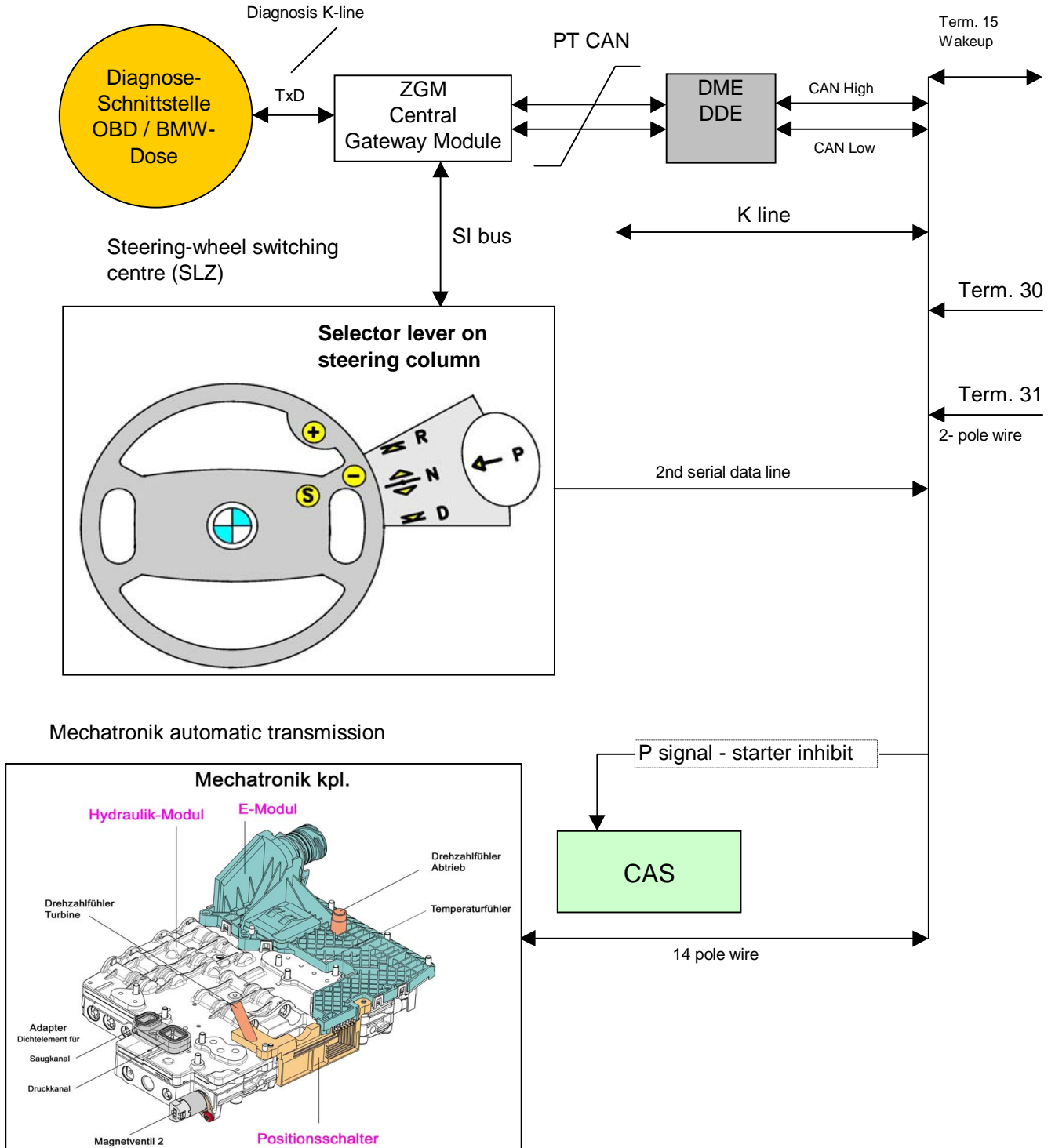

Symbols displayed in regular driving (not emergency run mode)

1. Position "P"- Park

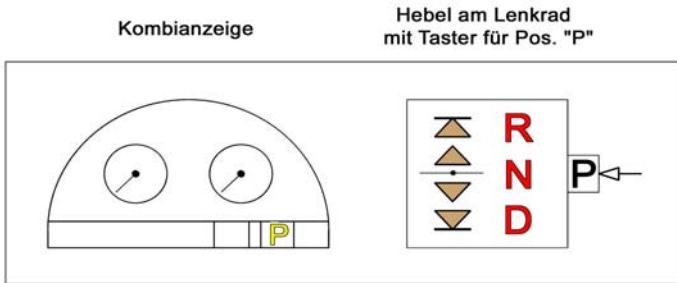

Position P is not part of the actual gear shift gate and is therefore shown on the instrument panel display as a telltale lamp when it is selected.

2. Position "R"- Reverse

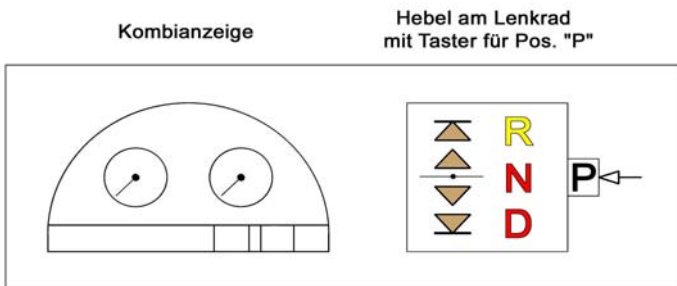

Steering wheel lever moved to R. The R position display is highlighted when reverse gear is engaged. The position display is visible when the ignition is on and if the transmission is not in the P position.

3. Position "N"- Neutral

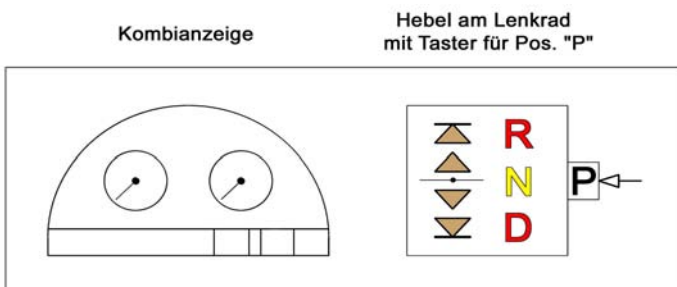

Steering wheel lever moved to N. The N position display is highlighted when neutral is selected. The position display is visible when the ignition is on and if the transmission is not in the P position.

4. Position "D"- Drive (normal forward travel)

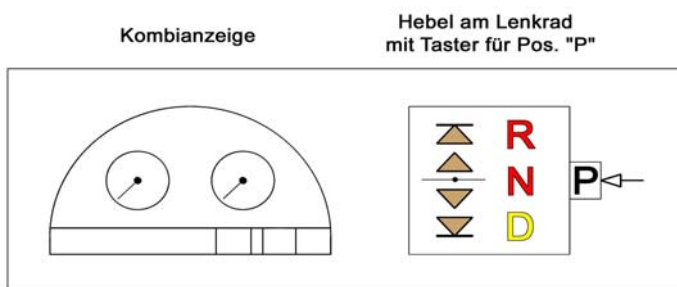

Steering wheel lever moved to D. The D position display is highlighted when neutral is selected. The position display is visible when the ignition is on and if the transmission is not in the P position.

Program selection

5. Position "D", S program (sport)

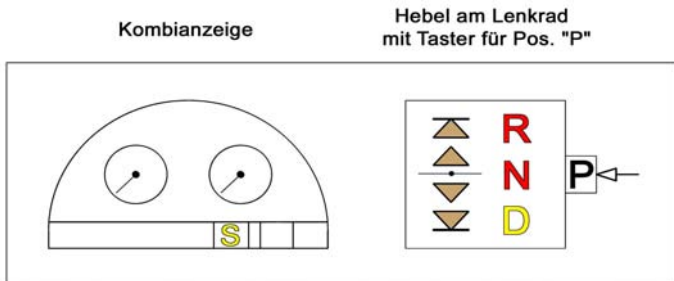

Steering wheel lever moved to D.
 The D position display is highlighted when neutral is selected.
 The position display is visible when the ignition is on and if the transmission is not in the P position.

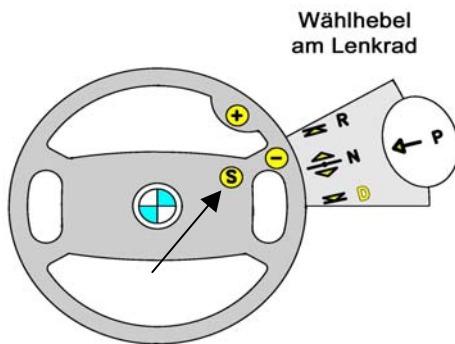

Press the S pushbutton on the multi-functional steering wheel.
 The sport program is indicated by an S telltale lamp on the instrument panel.

6. Position "D"- manual selection program (Steptronic mode M1...M6)

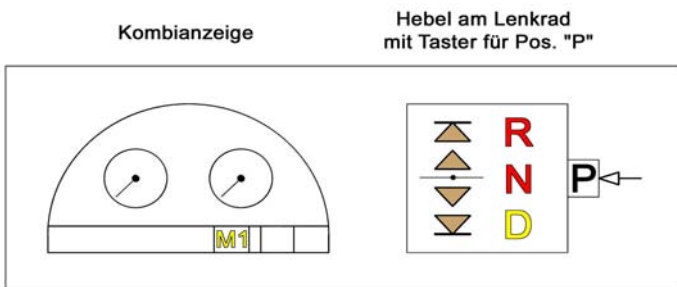

Steering wheel lever moved to D.
 The D position display is highlighted when neutral is selected.
 The position display is visible when the ignition is on and if the transmission is not in the P position.

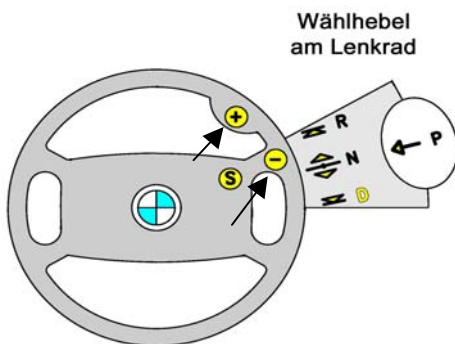

Press the (+) or (-) button on the multi-functional steering wheel.
 (+) = upshifts, (-) = downshifts

The sport program is shown by the M1....M6 telltale lamps on the instrument panel.

Symbols displayed in emergency run mode

Mechanical-shift transmission - emergency run with power available forwards and CAN communication

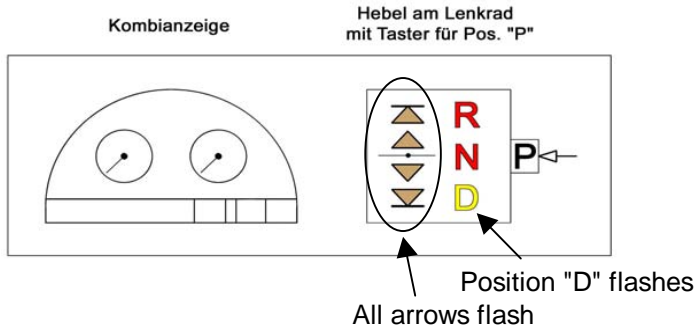

The EGS controls the instrument panel display. All arrows flash. The R, N and D position lights remain on. Position light D flashes alternately with the other position lights.

Mechanical-shift transmission - emergency run in position P with CAN communication

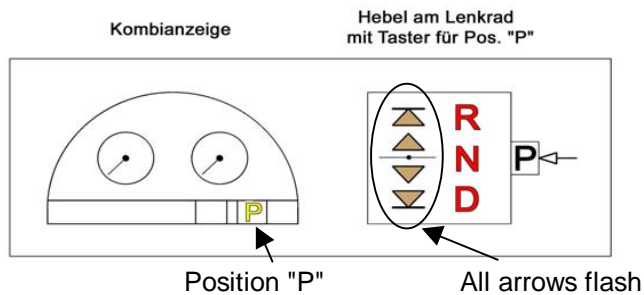

The EGS controls the instrument panel display. All arrows flash. Position lights R, N and D remain on. Position "P" is highlighted.

Mechanical or electronic transmission - emergency run without CAN communication

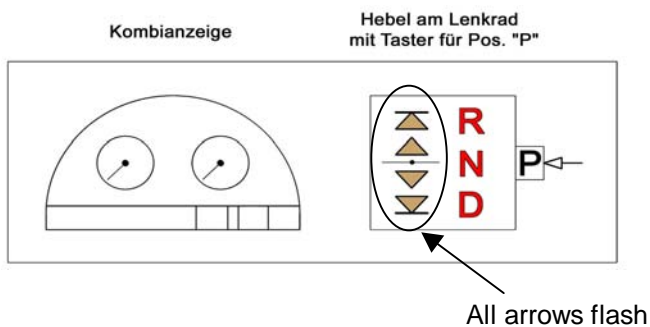

If the EGS fails completely or there is a CAN bus fault, the instrument panel itself controls the display. All arrows flash. Position lights R, N and D remain on. The position display is switched off.

When the ignition is switched on and the engine started, the gate pattern and transmission position "P" or "N" will be displayed. All arrows are shown. In transmission positions D or R only the arrow for the permissible shift direction is shown instead of position "N".

Description of gears / power flow

Power flow in 1st gear

Shift elements: Clutch A
 Brake D

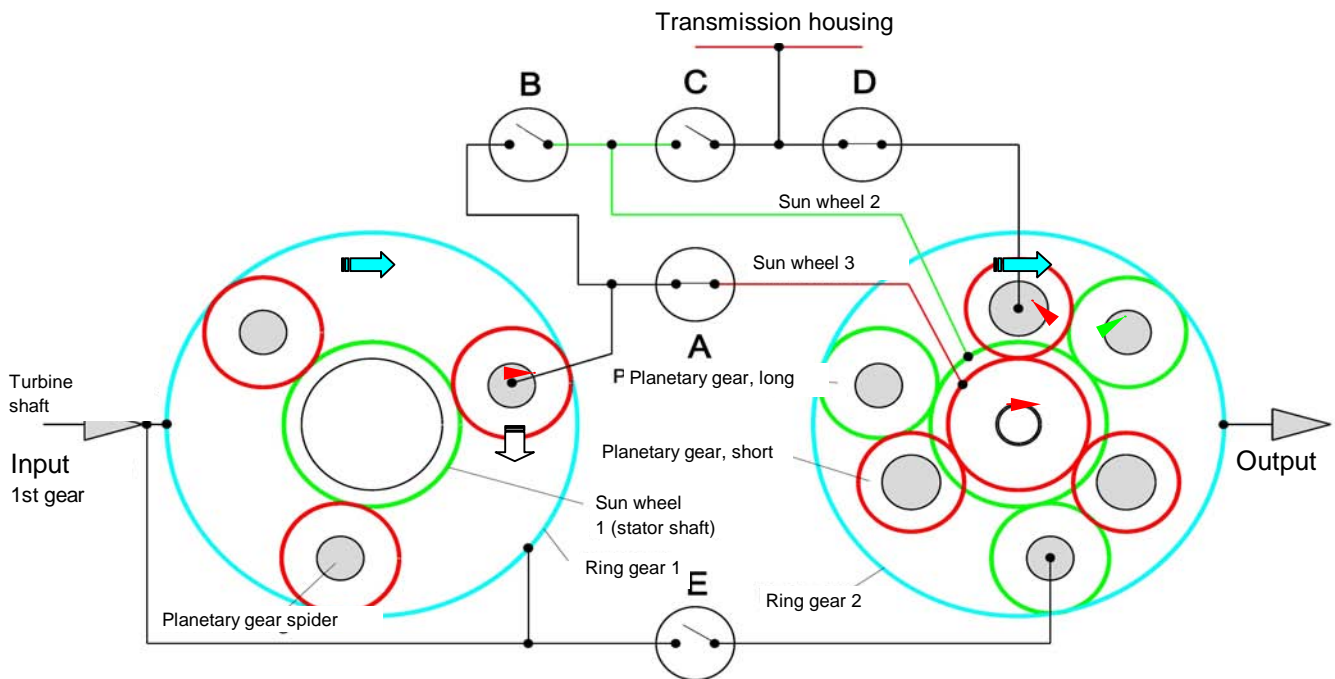
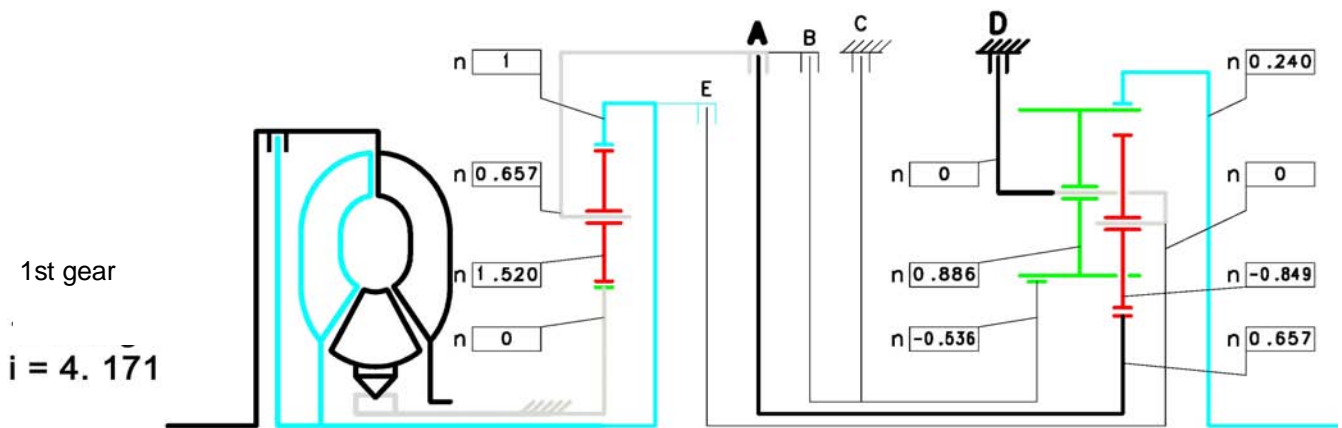

Description of 1st gear power flow

The turbine shaft drives the ring gear of the front, single planetary gear set and the outer plate carrier of clutch "E".

Ring gear 1 drives the planetary gears that roll round fixed sunwheel 1. This drives planetary gear spider 1 and also the outer plate carrier "A" and the inner plate carrier of clutch "B".

When clutch "A" is engaged, sun wheel 3 in the double planetary gear set is driven; this meshes with the short planetary gears. The double planetary gear set bears against the transmission housing by way of brake "D". This enables ring gear 2 (output shaft) to be driven in the same direction as the engine via the long planetary gears.

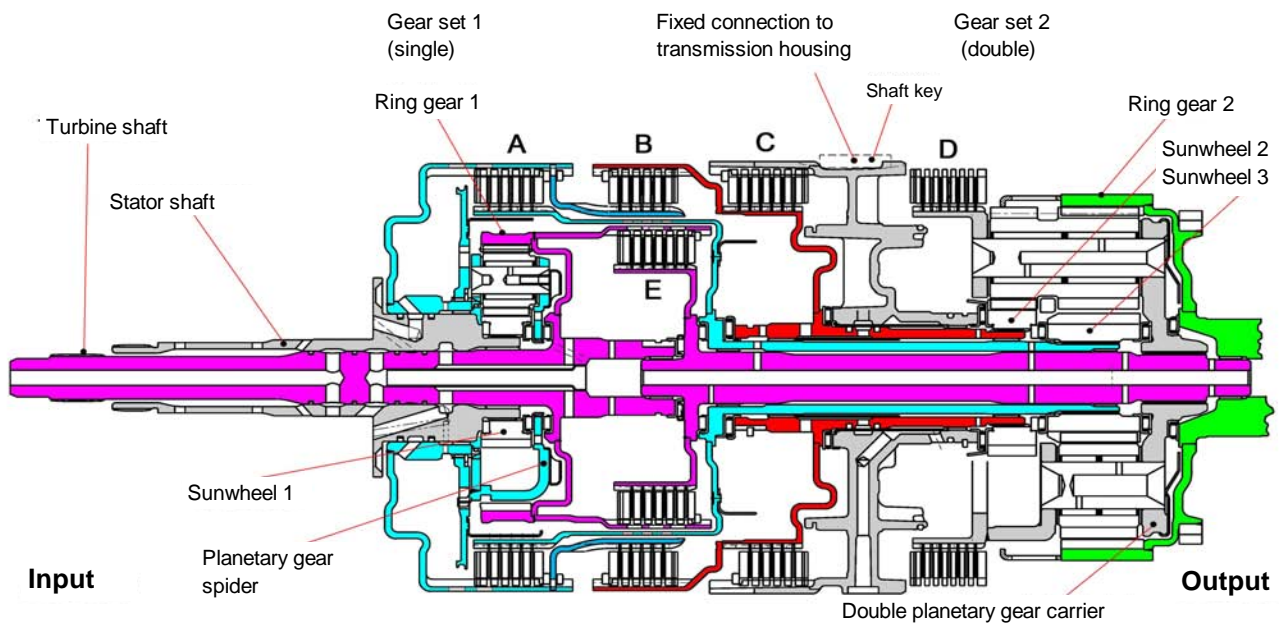

Power flow in 2nd gear

Shift elements:

Clutch
Brake

A
C

2nd gear
 $i = 2.340$

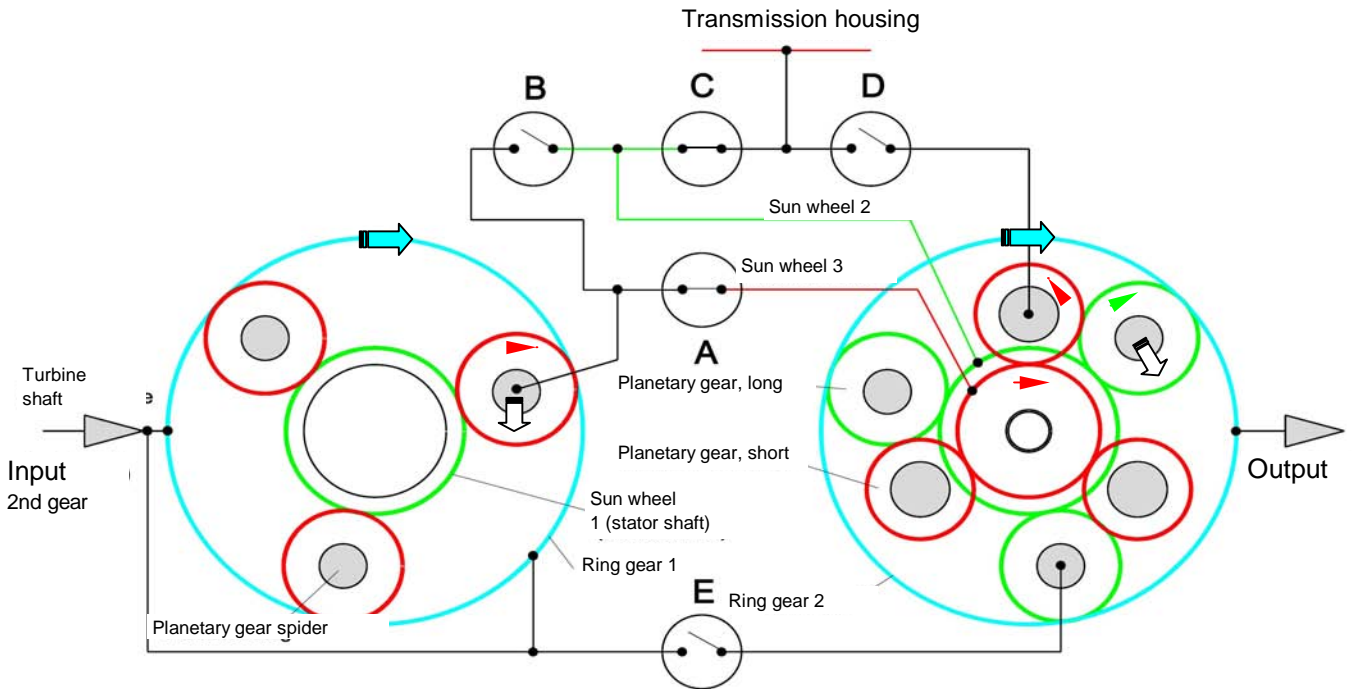
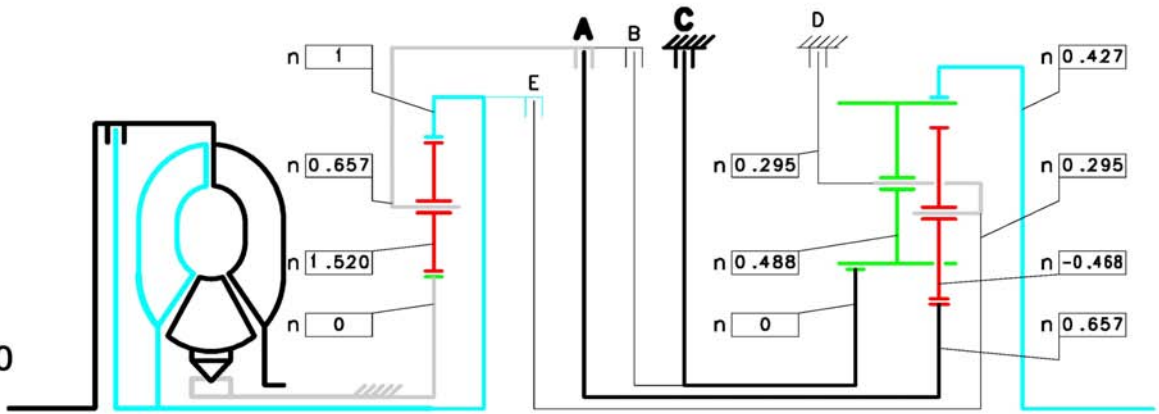

Description of 2nd gear power flow

The turbine shaft drives the ring gear of the front, single planetary gear set and the outer plate carrier of clutch "E".

Ring gear 1 drives the planetary gears that roll round fixed sunwheel 1. This drives planetary gear spider 1 and also outer plate carrier "A" and the inner plate carrier of clutch "B".

When clutch "A" is engaged, sunwheel 3 in the double planetary gear set is driven; this meshes with the short planetary gears.

Sunwheel 2 is locked to the transmission housing by brake "C". The long planetary gears, which are meshed with the short planetary gears, roll round the fixed sunwheel 2 and drive the double planetary gear spider and ring gear 2 in the direction of engine rotation.

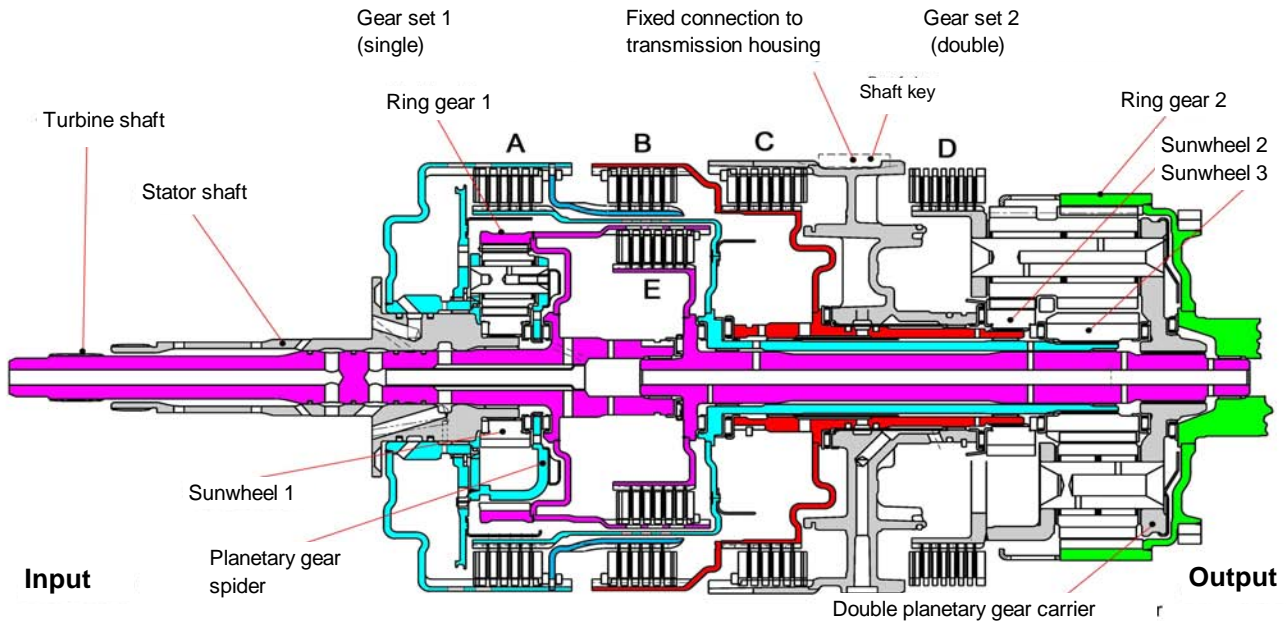

Power flow in 3rd gear

Shift elements:

Clutch
Clutch

A
B

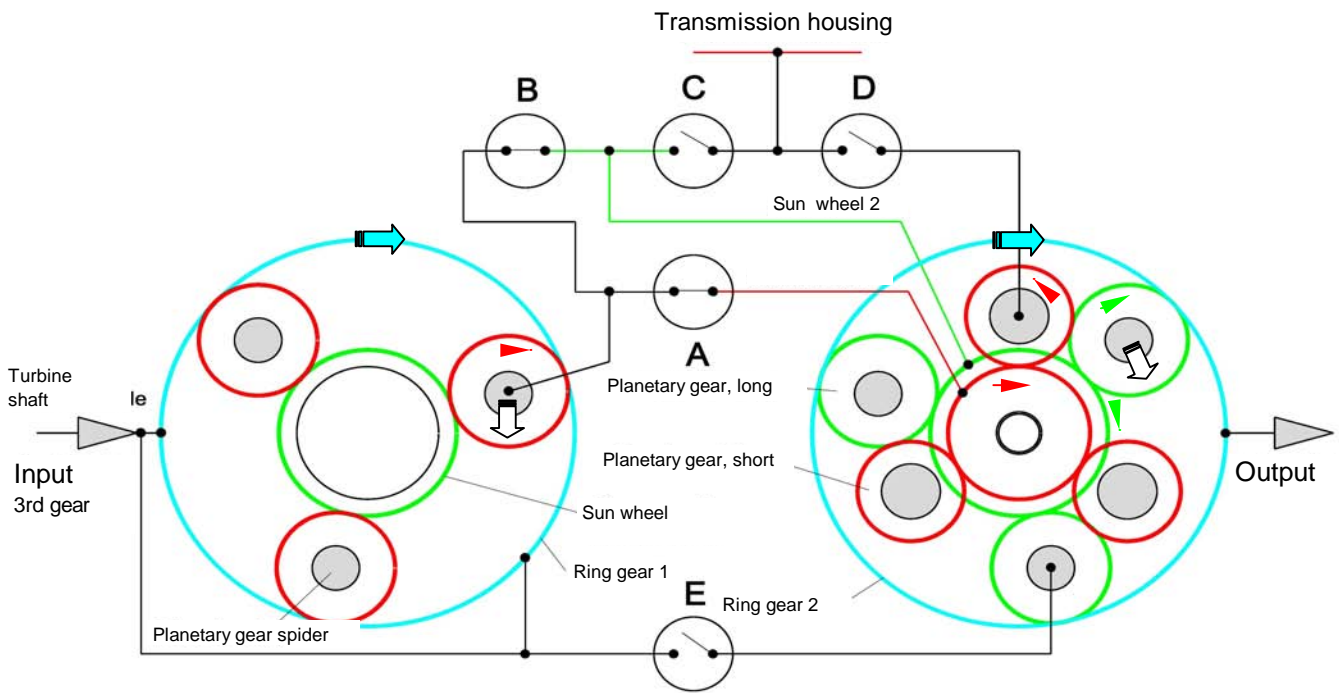
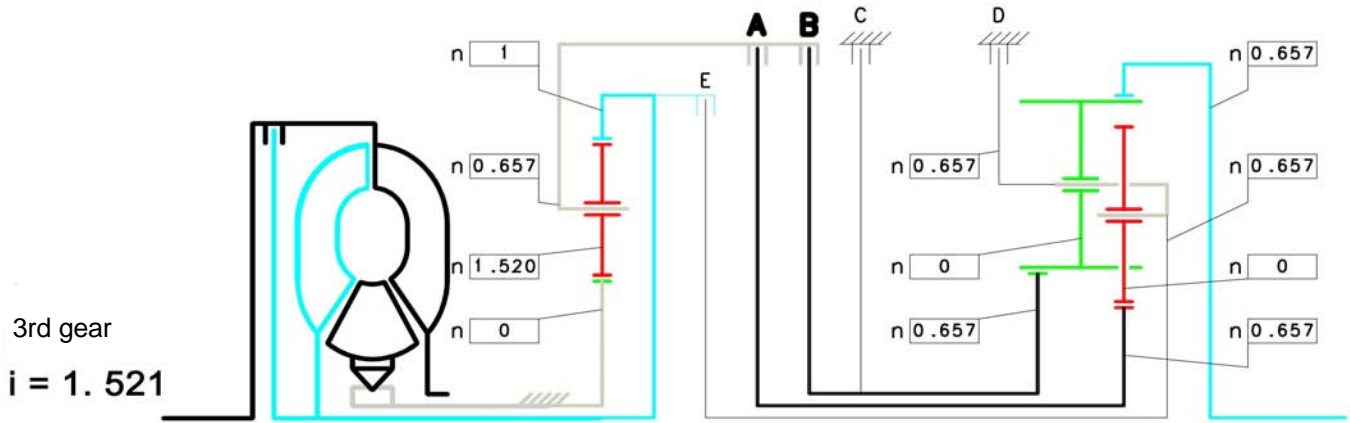

Description of 3rd gear power flow

The turbine shaft drives the ring gear of the front, single planetary gear set and the outer plate carrier of clutch "E".

Ring gear 1 drives the planetary gears, which roll round fixed sunwheel 1. This drives planetary gear spider 1 and at the same time outer plate carrier "A" and the inner plate carrier of clutch "B".

With clutch "A" engaged, sunwheel 3 in the double planetary gear set is driven; this meshes with the short planetary gears.

Sunwheel 2 is driven via engaged clutch "B".

The long planetary gears, which are in engagement with the short ones, can not roll round fixed sunwheel 2 and drive the blocked double planetary gear carrier in the direction of engine rotation.

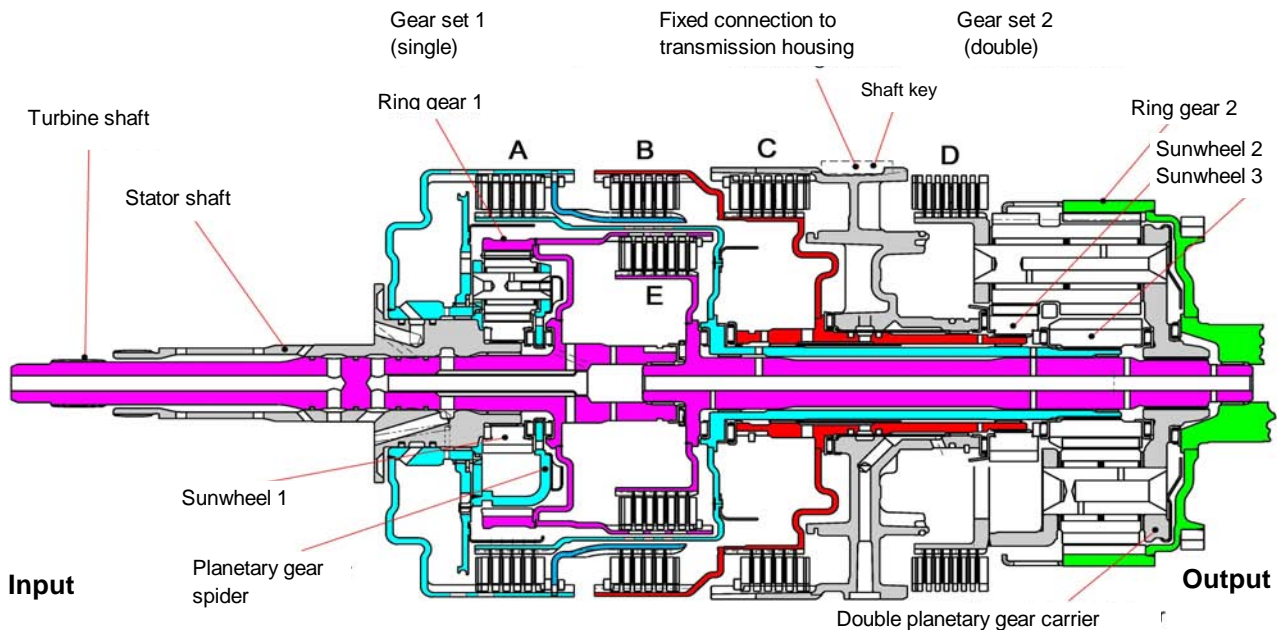

Power flow in 4th gear

Shift elements:

Clutch
Clutch

A
E

4th gear
 $i = 1.143$

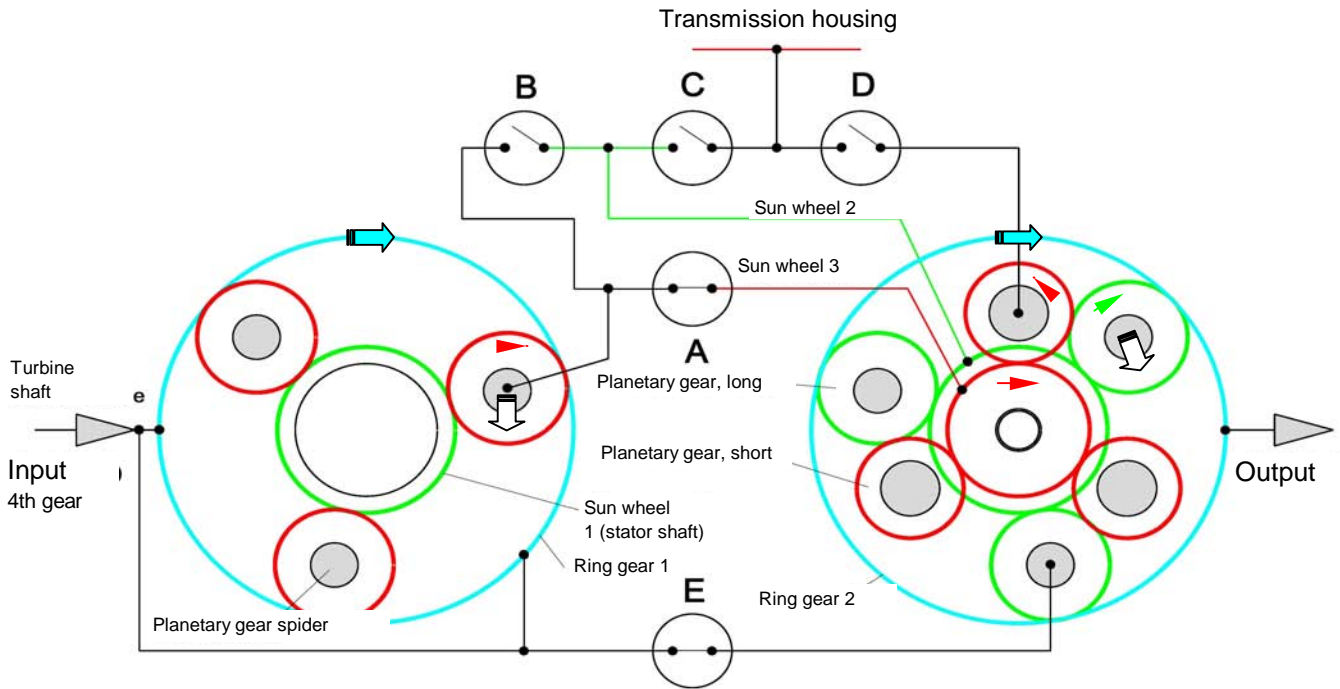
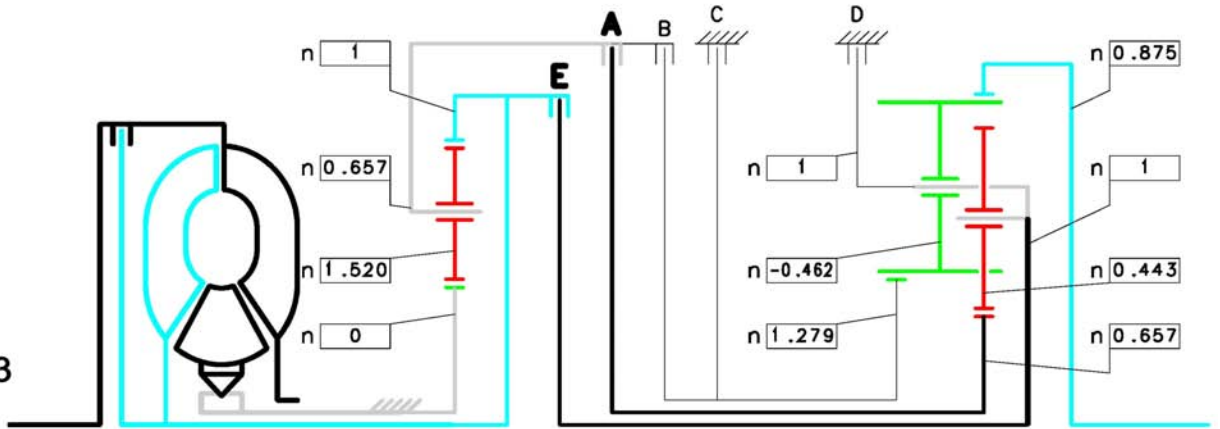

Description of 4th gear power flow

The turbine shaft drives the ring gear of the front, single planetary gear set and the outer plate carrier of clutch "E".

Ring gear 1 drives the planetary gears, which roll round fixed sunwheel 1. This drives planetary gear spider 1 and at the same time outer plate carrier "A" and the inner plate carrier of clutch "B".

With clutch "A" engaged, sunwheel 3 in the double planetary gear set is driven; this is in mesh with the short planetary gears.

The double planetary gear spider is driven via engaged clutch "E". The long planetary gears, which are in mesh with the short ones, drive (together with the double planetary gear spider) ring gear 2 in the direction of engine rotation.

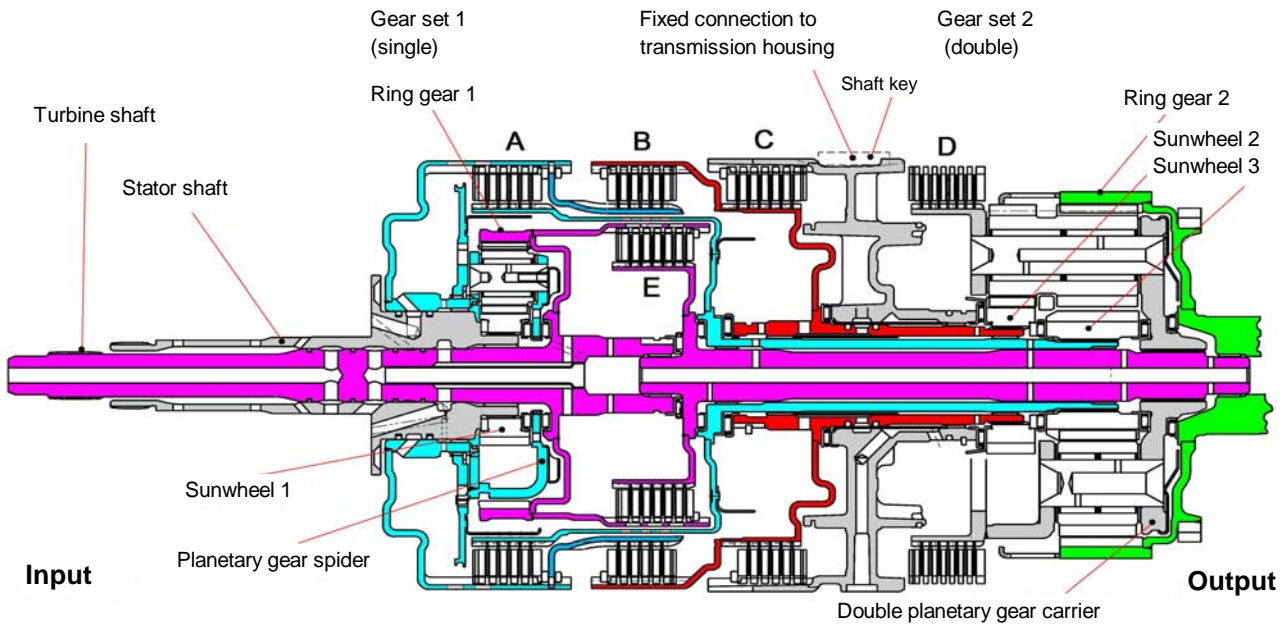

Power flow in 5th gear

Shift elements:

Clutch
Clutch

B
E

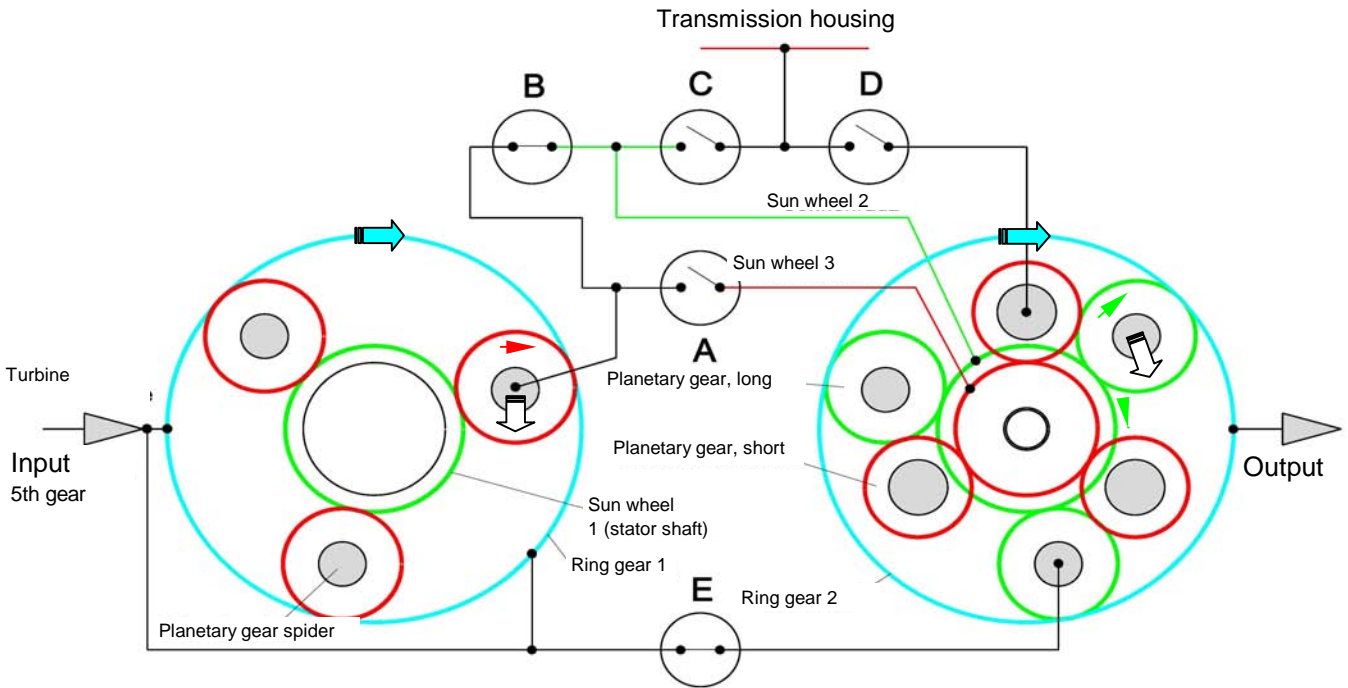
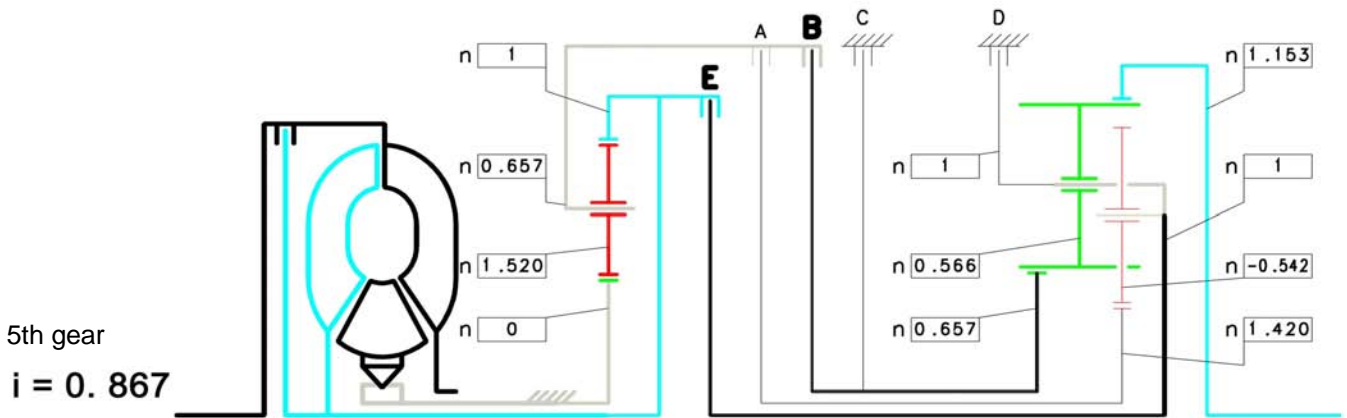

Description of 5th gear power flow

The turbine shaft drives the ring gear of the front, single planetary gear set and the outer plate carrier of clutch "E".

Ring gear 1 drives the planetary gears, which roll around fixed sunwheel 1. This drives planetary gear spider 1 and at the same time outer plate carrier "A" and the inner plate carrier of clutch "B".

With clutch "A" engaged, sunwheel 3 in the double planetary gear set is driven; this is in mesh with the short planetary gears.

The double planetary gear spider is driven via the engaged clutch "E" and sunwheel 2 via engaged clutch "B".

The long planetary gears, which are in mesh with the short ones, drive (jointly with the double planetary gear spider) ring gear in the direction of engine rotation.

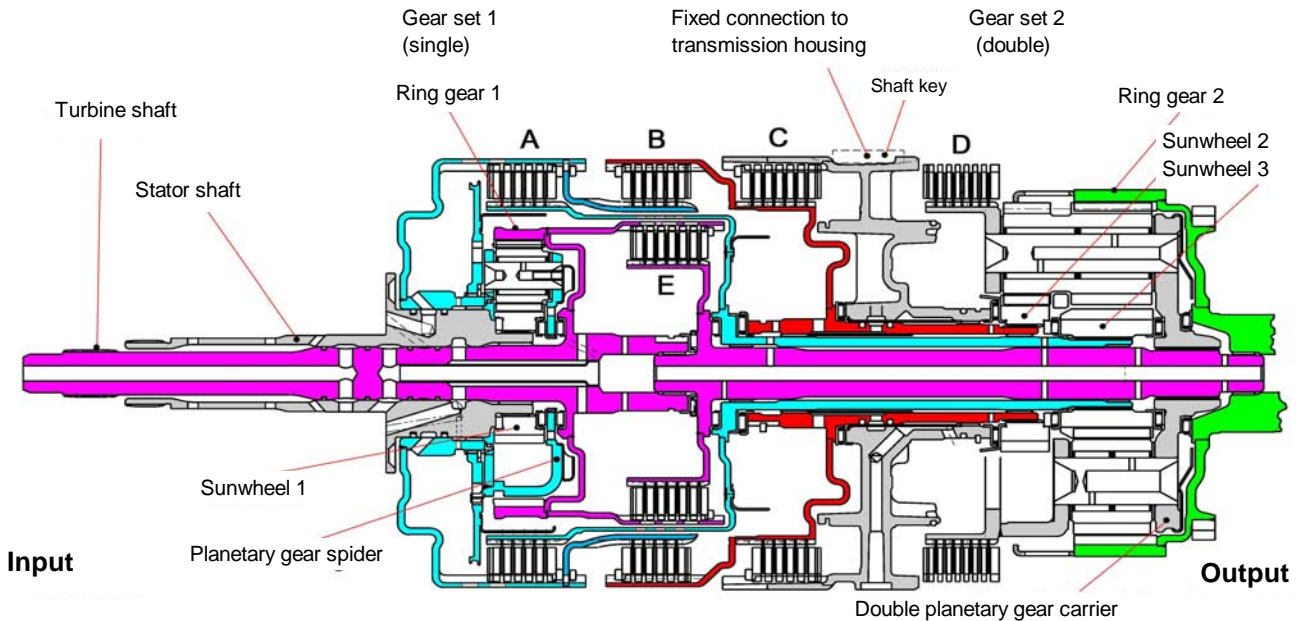

Power flow in 6th gear

Shift elements:

Brake
Clutch

C
E

6th gear
 $i = 0.691$

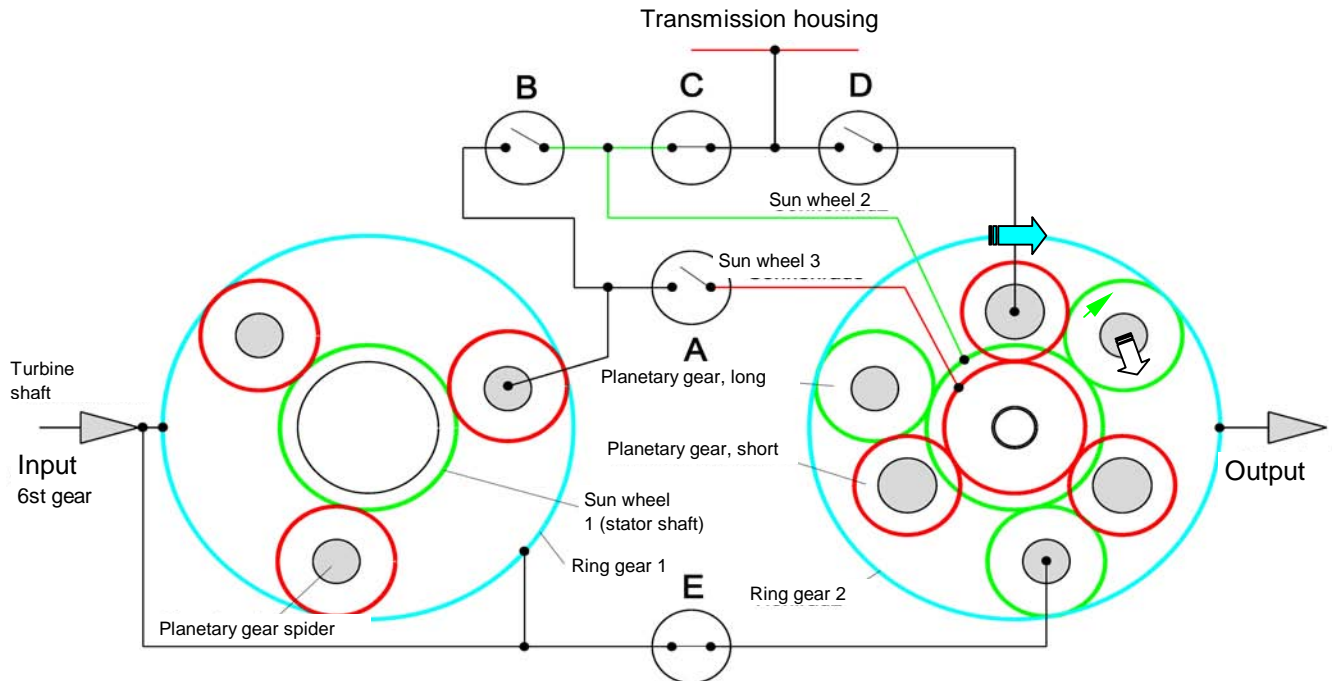
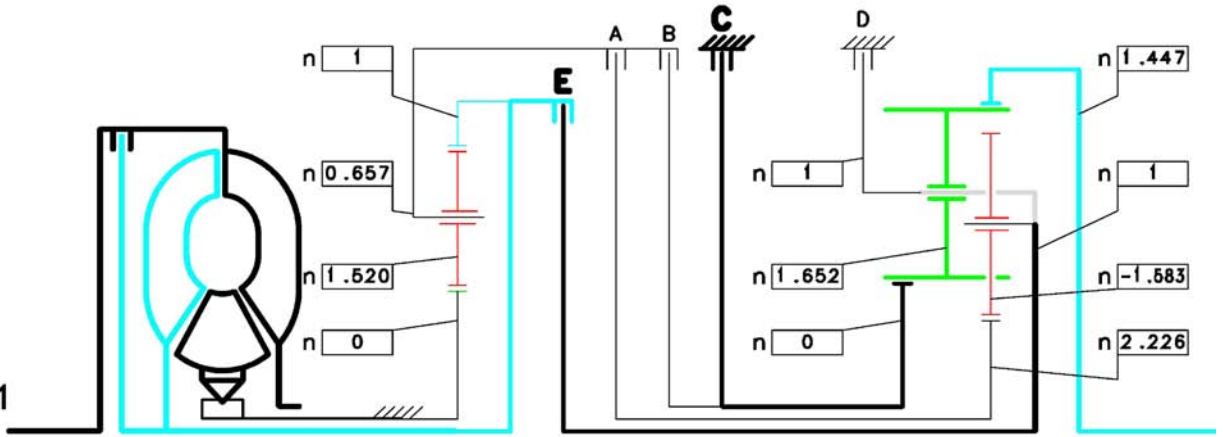

Description of 6th gear power flow

The turbine shaft drives ring gear 1 and the outer plate carrier of clutch "E".

Clutches "A" and "B" are released, so that the front planetary gear set has no effect.

Sunwheel 2 is locked to the transmission housing via brake "C", which is applied.

The double planetary gear spider is driven via engaged clutch "E", so that the long planetary gears roll round fixed sunwheel 2 and ring gear 2 is driven in the direction of engine rotation.

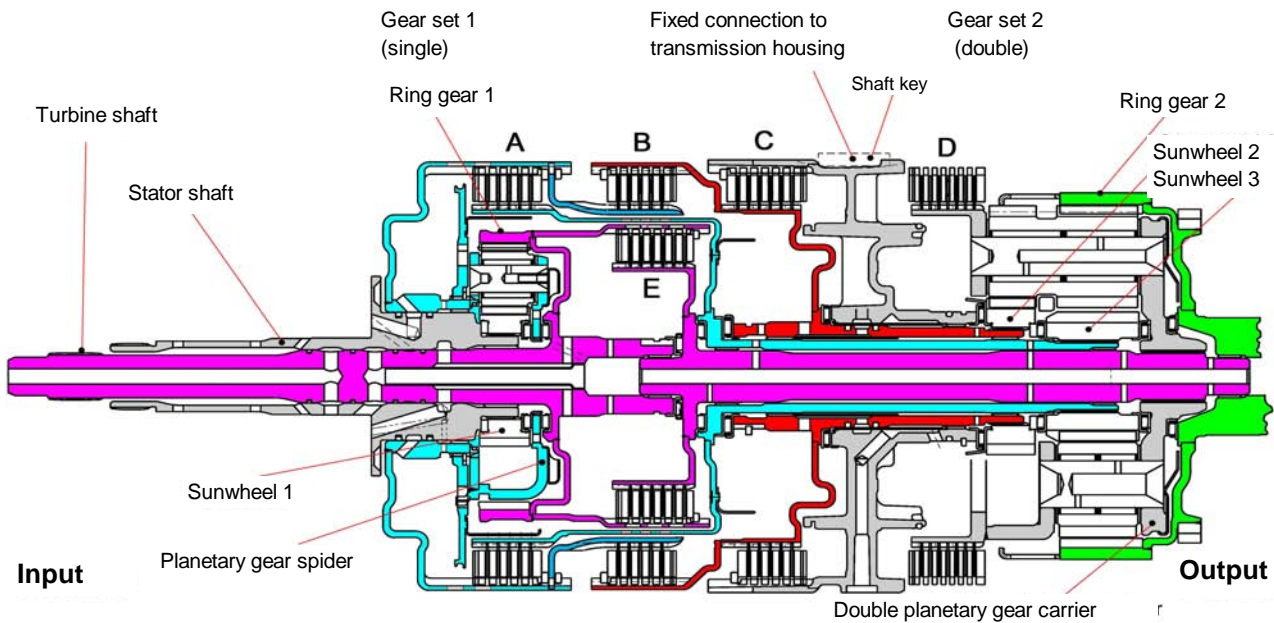

Power flow in Reverse

Shift elements:

Clutch
Brake

B
D

Reverse gear
 $i = - 3.403$

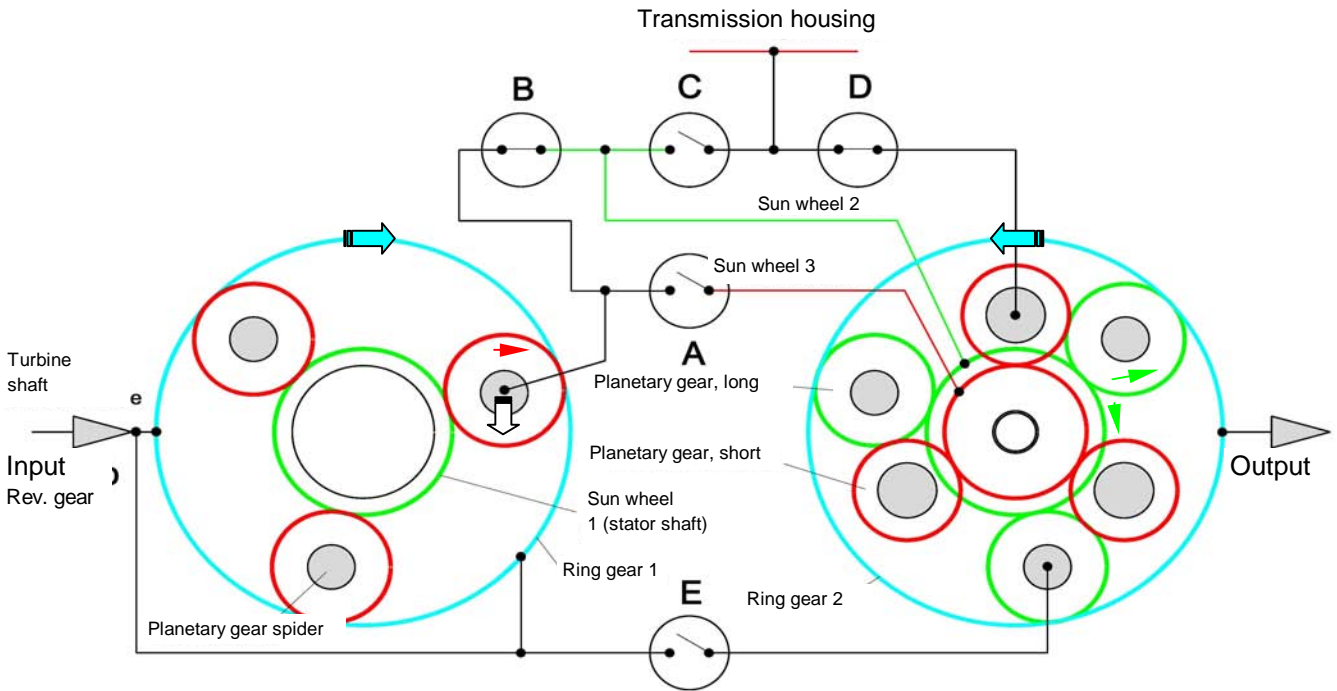
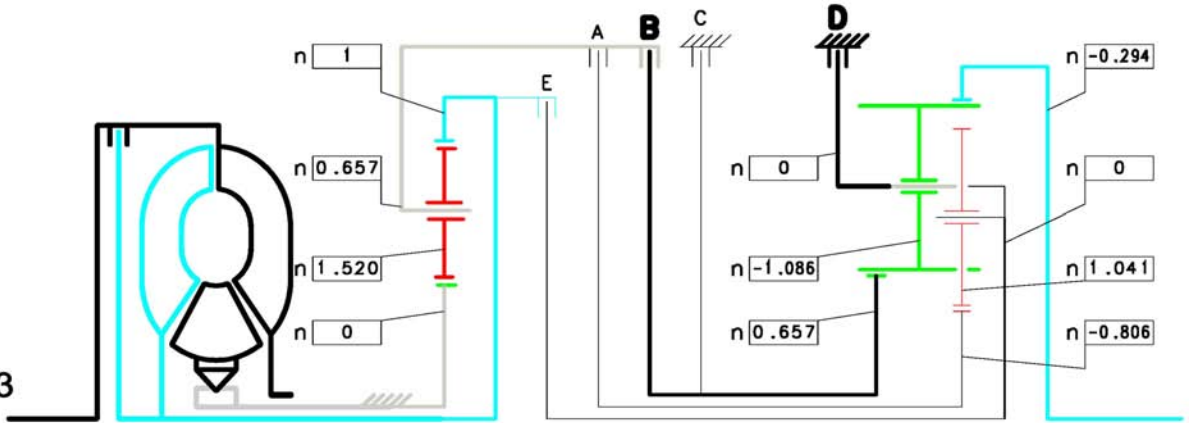

Description of Reverse gear power flow

The turbine shaft drives the ring gear of the single front planetary gear set and the outer plate carrier of clutch "E".

Ring gear 1 drives the planetary gears, which roll round fixed sunwheel 1. This drives planetary gear spider 1 and also outer plate carrier "A" and the inner plate carrier of clutch "B".

When clutch "B" is engaged, sunwheel 2 in the double planetary gear set is driven; it is in mesh with the long planetary gears.

The double planetary gear spider is locked to the transmission housing by brake "D". As a result, ring gear 2 (output shaft) can be driven in the opposite direction to engine rotation by way of the long planetary gears.

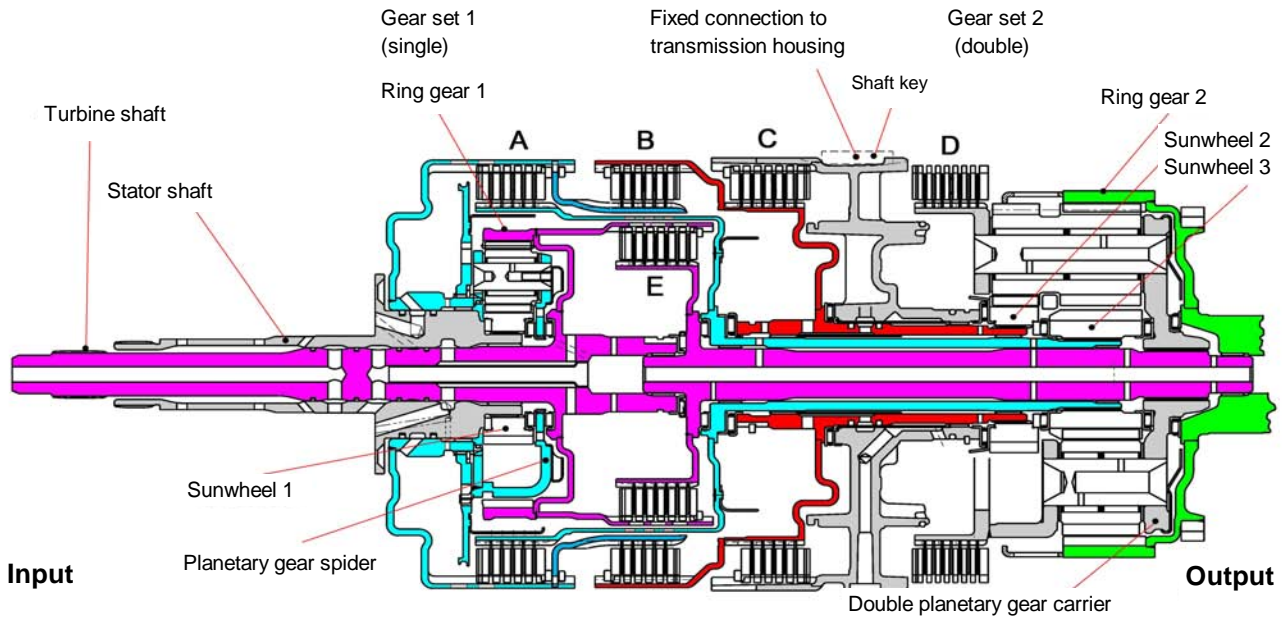

6HP26 E20 E- Schaltung

Pos / Gear	Solenoid / Regulator Valve Logic									Clutch-Logic					
	MV			P- EDS						Clutch				Brake	
	1	2	3	1	2	3	4	5	6	A	B	E	WK	C	D
P = Parken							X	-X-							●
R = R- Gang	X	X	X		X		X	-X-			●				●
N = Neutral	X	X	X				X	-X-							●
D, 1. Gang	X	X	X	X			X	-X-	-X-	●			●		●
D, 2. Gang	X	X	X	X		X		-X-	-X-	●			●	●	
D, 3. Gang			X	X	X			-X-	-X-	●	●		●		
D, 4. Gang	X		X	X			X	-X-	-X-	●		●	●		
D, 5. Gang	X		X		X		X	-X-	-X-		●	●	●		
D, 6. Gang	X		X			X	X	-X-	-X-			●	●	●	
	Schaltventil 1	Parksperrren- Ventil	Parksperrren- Zylinder	Kupplung A	Kupplung B	Bremse C	Bremse D / Kupplung E	System- Druck	Regelung zur Ganglogik (situationsbedingt)	Planetensteg 1. Radsatz	Sonnenrad 1 (Doppelradsatz)	Steg Doppelradsatz	situationsbedingte Regelung der Wandlerüberbr.- Kupplung	Sonnenrad Nr. 1 (Doppelradsatz)	Planetensteg (Doppelradsatz)

6HP26 E20 M- Schaltung

Pos / Gear	Solenoid / Regulator Valve Logic									Clutch-Logic					
	MV			P- EDS						Clutch				Brake	
	1			1	2	3	4	5	6	A	B	E	WK	C	D
P = Parken							X	-X-							●
R = R- Gang					X		X	-X-			●				●
N = Neutral							X	-X-							●
D, 1. Gang				X			X	-X-	-X-	●			●		●
D, 2. Gang				X		X		-X-	-X-	●			●	●	
D, 3. Gang				X	X			-X-	-X-	●	●		●		
D, 4. Gang	X			X			X	-X-	-X-	●		●	●		
D, 5. Gang	X				X		X	-X-	-X-		●	●	●		
D, 6. Gang	X					X	X	-X-	-X-			●	●	●	
	Schaltventil 1			Kupplung A	Kupplung B	Bremse C	Bremse D / Kupplung E	System- Druck	Regelung zur Ganglogik (situationsbedingt)	Planetensteg 1. Radsatz	Sonnenrad 1 (Doppelradsatz)	Steg Doppelradsatz	situationsbedingte Regelung der Wandlerüberbr.-Kupplung	Sonnenrad Nr. 1 (Doppelradsatz)	Planetensteg (Doppelradsatz)

Hydraulic circuit diagram (E shift)

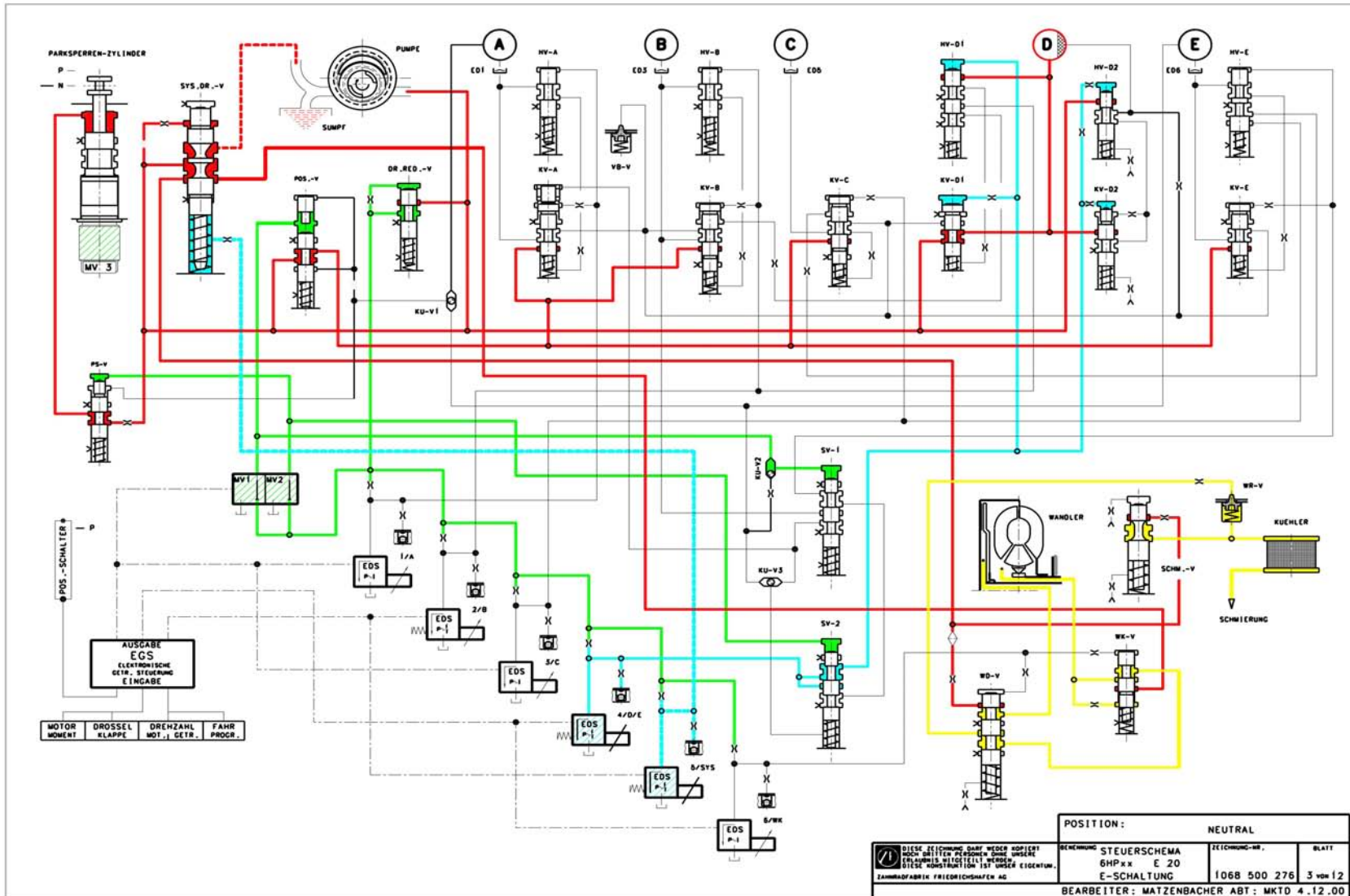

Hydraulic circuit diagram (M shift)

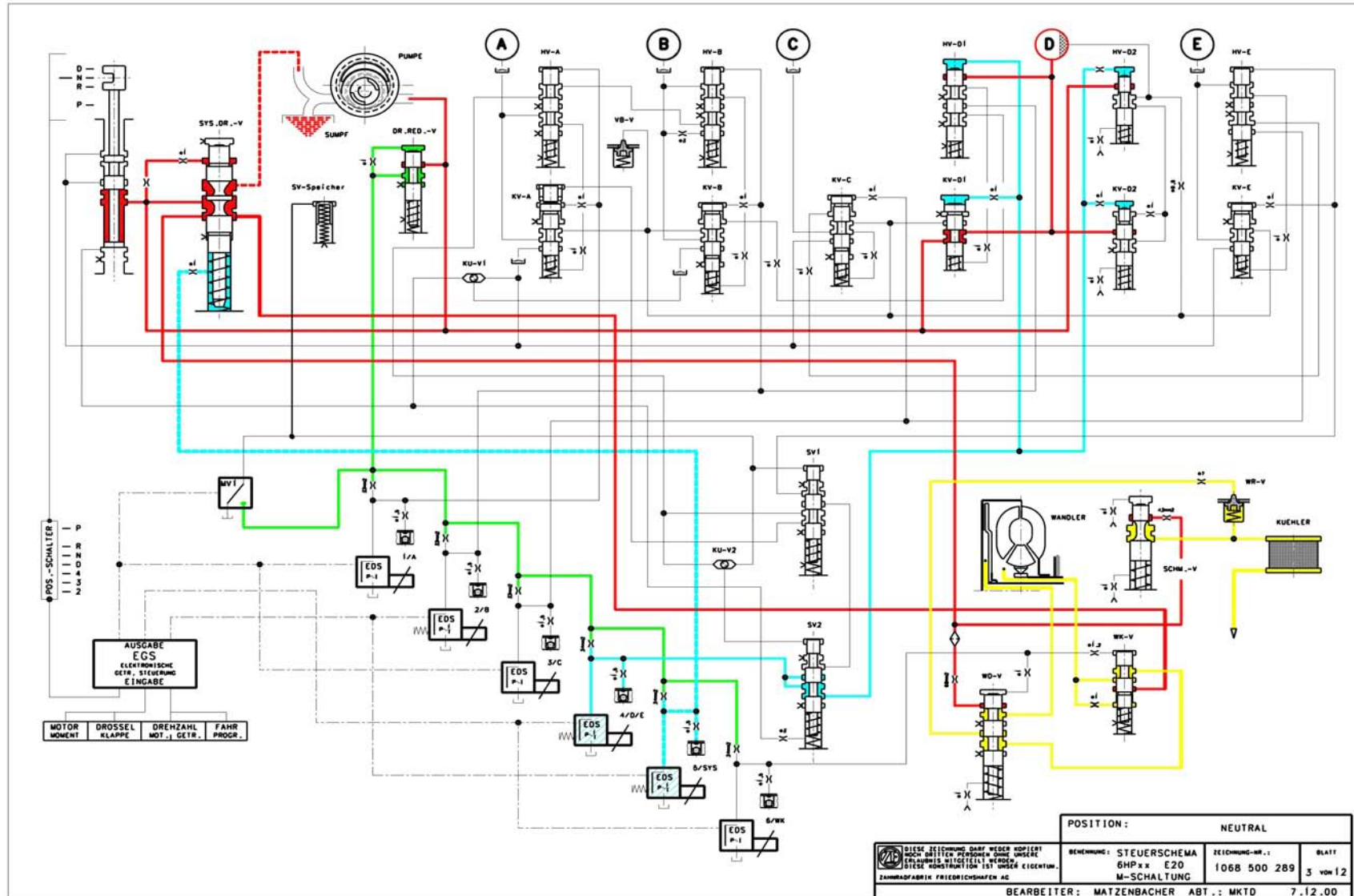

Mechatronik module

Hydraulic and electronic control units

General:

The Mechatronik module is a combination of hydraulic and electronic control units. Both these modules are installed in the transmission, in the oil pan area.

This technical principle has the following advantages:

- minimum tolerances
- better coordination of gear shifts
- increased refinement
- optimised shift quality
- good reliability, since the number of plug connections and interfaces is reduced

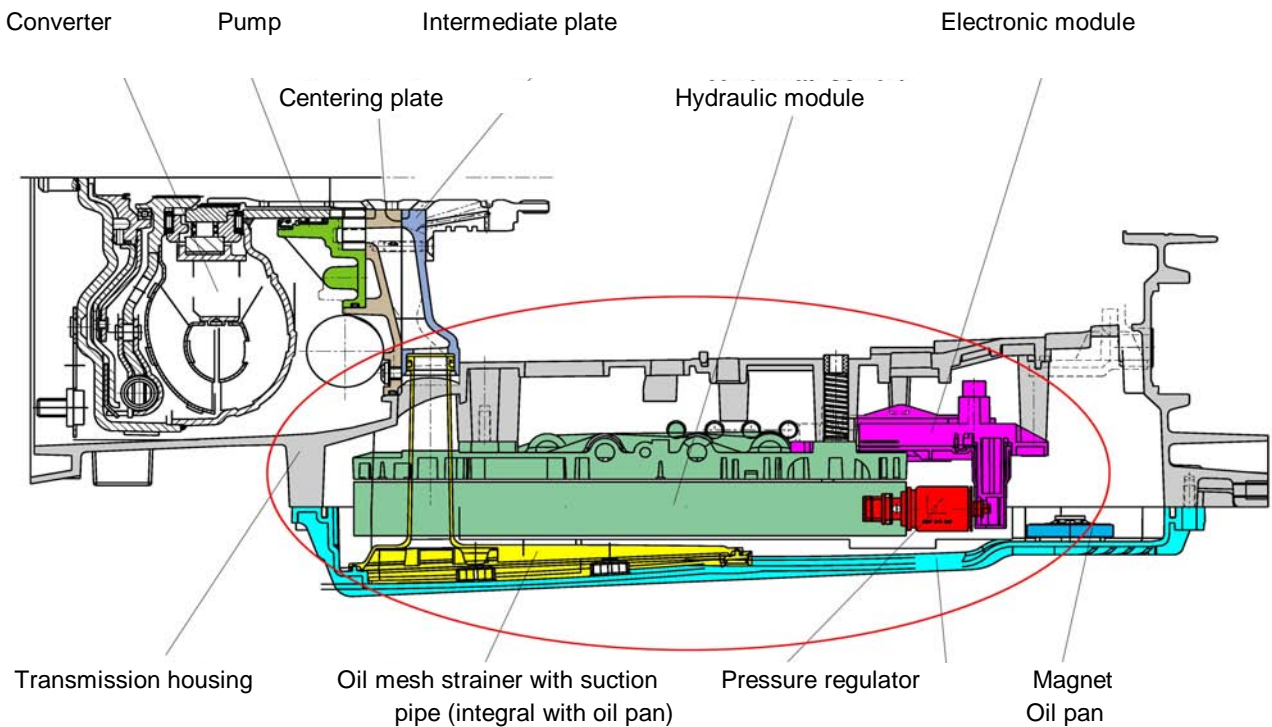

When working on the Mechatronik, for example during a repair, suitable safety precautions must be taken, particularly against ESD.

Please refer to Standard DIN EN 100015 ESD manual issued by the Electronics Committee of the German VDE / VDI Micro-electronics Society (GME).

Here are a few extracts of particular relevance:

The term ESD stands for **E**lectro**s**tatic **D**ischarge.

The human body, if electrically charged but not properly earthed (grounded), moves in an electrostatic 'cloud' and therefore endangers electronic components.

It is therefore essential to wear electrically conductive footwear and a closed protective outer garment.

Everyone must take precautions to avoid damage from electrostatic discharge:

- when incoming goods are received
- in the incoming goods test area
- in production or repair shops and also when visiting the parts store, even for a short time
- in the despatch area
- in the transport or shipping area

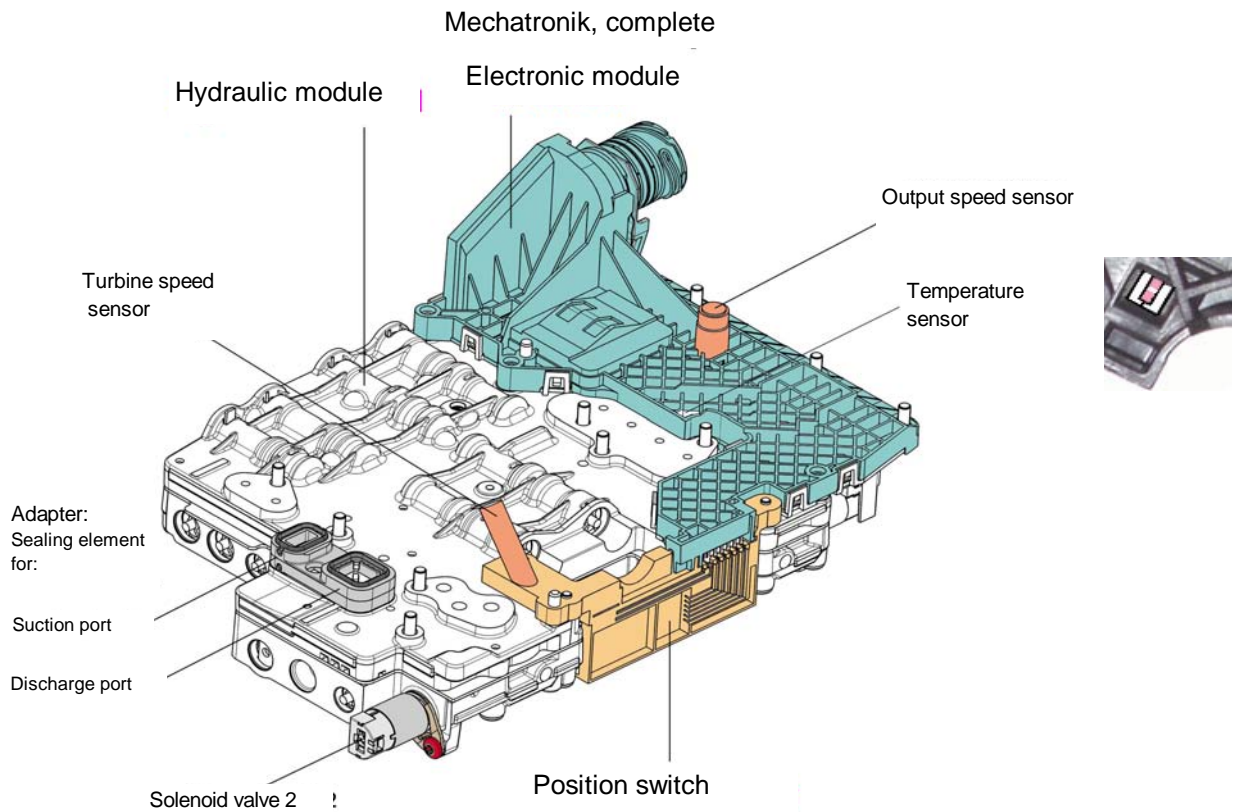

What personal precautions must be taken?

- Always note and comply with the personal protective measures:
 - In zones exposed to the risk of electrostatic discharge, always wear the correct protective coat and electrically conductive shoes
 - When working seated in a risk area, always wear an earthed (grounded) wrist band
 - Do not touch any open equipment or components without sufficient potential equalisation
- In electrostatic discharge risk zones, use only permitted means of transportation and packing materials:
 - transport crates
 - component packs
 - stores and racks
 - transport trolleys and other vehicles
- Only approved working equipment should be used:
 - earthed (grounded) soldering irons
 - earthed (grounded) solder removal tools
 - permitted auxiliary devices and tools
- Keep all insulating synthetic materials away from the work area, in particular:
 - polyethylene bags
 - polystyrene elements
 - Cellophane film
 - PVC bags, film or sleeves

Detailed instructions are given in Siemens production directive F12F1542 and in process description 051 "Manufacturing instructions for the avoidance of electrostatic discharge".

Take great care wherever you see this sign:



It is displayed near components or assemblies that are sensitive to electrostatic discharge.

Electrostatic discharge protective zones

There are various forms of electrostatic discharge protective zone:

Stationary

- Individual work station
- Workbench, desk
- Store, factory building, office
- Individual cupboards or shelves
- Service
- After-sales service

In addition to the protection afforded by electrostatic discharge protection zones, personal safety must also be guaranteed. Comply with industrial accident precautions, particularly DIN VDE 0104.

Equipment in electrostatic discharge protection zones

All areas at which work is done on electronic components and equipment should be protected against electrostatic discharge. Try to incorporate them all into a single large protection zone.

Minimum equipment, for example when a conventional work area is converted:

- Personnel earthed (grounded) with wrist band
- Table top material or mat connected to potential equalisation
- Protective packs to prevent electrostatic discharge
- The following must be electrically conductive:
 - Table top material
 - Working clothing
 - Transportation systems and storage boxes or bins

Optimum equipment, i.e. when setting up new work stations protected against electrostatic discharge:

- Personnel earthed (grounded) with wrist band (1)
- Work tables, benches and shelves connected to potential equalisation (2)
- Protective packs to prevent electrostatic discharge (3)
- Signs identifying an electrostatic discharge protection zone (4)
- Tester for personnel earthing (grounding) by means of wrist band (5)
- Tester for personnel earthing (grounding) through shoes (6)
- The following must be electrically conductive:
 - Table or bench top (7)
 - Working clothing (8)
 - Transportation systems and storage boxes or bins (9)
 - Flooring material (10)
 - Chairs (11)
 - Shoes or foot earthing (grounding) straps (12)
 - Gloves or mittens, as necessary (13)
 - Shelves (14)
 - Tools (15)

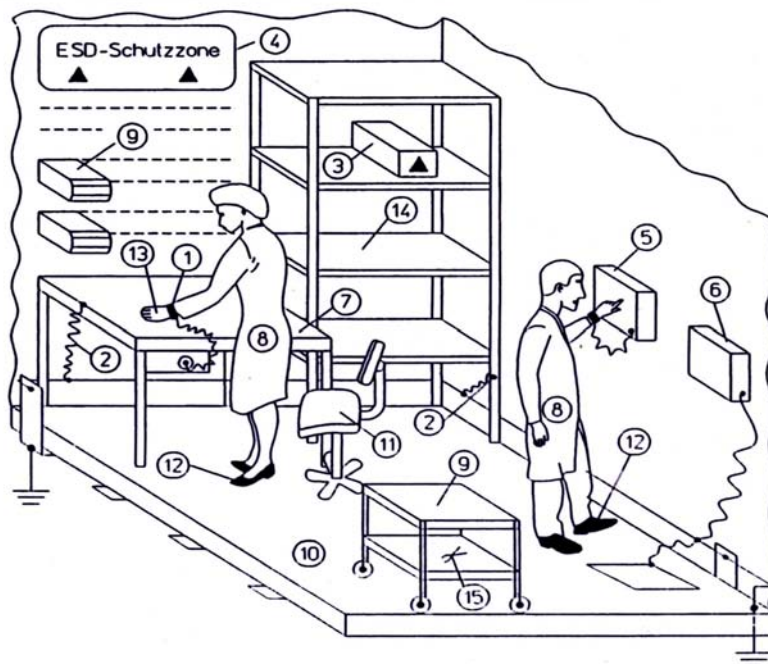

Identification of components and assemblies exposed to electrostatic discharge risk

Assemblies containing components exposed to electrostatic discharge risk must be marked with a warning symbol as a reminder that they need special handling. Self-adhesive labels should not be attached directly to electrostatic discharge risk components, since this could increase the risk of electrostatic discharge occurring. In such cases, the warning must be attached to the packaging material.

Identification mark

ELECTROSTATIC DISCHARGE RISK



Identification of protection zones

Electrostatic discharge protection zones must be indicated by suitable signs (see illustration). The sign must be attached where it is easily visible. Its minimum size must be 300 mm x 150 mm. The background colour is yellow, with black artwork.

Identification sign

Translation:
 WARNING:
 ELECTROSTATIC DISCHARGE RISK ZONE
 NOTE HANDLING INSTRUCTIONS FOR COMPONENTS EXPOSED TO ELECTROSTATIC DISCHARGE RISK



ESD earthing (grounding) equipment

All ESD earthing (grounding) devices installed in electrostatic discharge protection zones must be marked to identify them, using suitable symbols that call for suitable protective measures to be taken. The markings must make the intended purpose clear, but any additional information that is provided must not distract attention from the basic warning.

Specimen signs for earthing (grounding) points

Translation:

EARTHING (GROUNDING) CONTACT POINT



Packs and transportation containers

Packs and containers used for components subject to electrostatic discharge risk must carry a suitable warning notice.

In addition, transportation packs that, for instance, leave a production zone, must contain a warning slip calling for the necessary special handling procedures.

Warning slip to accompany items exposed to electrostatic discharge risk

Translation:
WARNING
COMPLY WITH
PRECAUTIONS FOR
HANDLING ELECTRO-
STATIC RISK COM-
PONENTS



Documentation

All documentation needed for the purchasing, specification, design or supply of electrostatic discharge risk components must contain notification for the user of the relevant handling regulations.

Packaging

A distinction is made between three types of packing. Electrostatic discharge protection must be provided by **packaging material in direct contact** with the items and by **loose wrappers** intended in particular for the items to be passed on under uncontrolled conditions outside protection zones. Outer packaging, however, does not have to provide ESD protection nor satisfy additional requirements such as protection against mechanical damage.

- **Packaging material in direct contact**

Packaging and auxiliary materials or means of transportation in direct contact with items exposed to ESD risk must be capable of minimising the tribo-electrical charge and ensuring charge dispersion, i.e. they must be both anti-static and electrostatically conductive. Any film, corrugated board, plastic packs etc. that are used must satisfy this requirement.

- **Loose wrappers**

Loose wrappers used to protect items exposed to ESD risk (voltages up to 4 kV or unknown) outside of ESD protection zones must be electrostatically screened. If they are used inside electrostatic discharge protection zones or if the parts are less sensitive to risk, the requirements can be reduced.

Loose filling material for packs must be **antistatic and electrically conductive** in order to eliminate any risk to the packed items.

Separate bags can be used as either direct-contact packaging material or loose wrappers.

This presupposes that they provide electrostatic screening, that the inner surface is antistatic and that both surfaces are electrostatically conductive.

- **Outer packaging**

Outer packaging material must satisfy all additional packaging requirements, for example protection against mechanical damage.

No electrostatic properties are required if protection against electrostatic discharge is provided by the inner packaging material. However, the outer material must be antistatic if the pack is to be transported into an ESD protection zone.

Personnel wrist-band earthing (grounding)

Earthing (grounding) by means of a wrist band or strap is the most reliable method of diverting electrostatic charges away from working personnel, and should therefore be used wherever possible, particularly if the person concerned is working while seated.

The wrist band earthing (grounding) device consists of a bracelet closely attached to the wrist and a spiral earthing (grounding) cable connecting it to the earthing (grounding) contact point.

This system must include a quick-release device so that the wrist can be freed in the event of danger.

- **Wrist band**

The inside surface of the wrist band must be electrically conductive, but the outer surface and edges must be electrically insulated.

- **Earthing (grounding) cable**

The earthing (grounding) cable must consist of an insulated wire which, at work areas with a nominal voltage up to 250 V, must be capable of accepting a test voltage of 4 kV without failure.

A **metallic-layer resistor** rated at **not less than 1 MOhm** with a **load factor of no less than 0.25 W** acc. to DIN 45921 Teil 107 (2) must be integrated into the earthing (grounding) cable.

This resistor must also be in accordance with DIN VDE 0860 (20, 21) and must not be capable of being bridged. It is to be installed at the cable end nearest the wrist band.

Total resistance must not exceed 5 MOhm.

The connectors used at earthing (grounding) points must **not fit the sockets of other systems**, e.g. alternating current plugs or laboratory apparatus sockets.

This requirement can be satisfied by the use of suitable pushbutton fittings or suitably insulated plugs.

Banana-pattern plugs in most cases **and crocodile clips in all cases (except for servicing work) are not permitted. Magnets are unsuitable** for earthing (grounding) point connections because they also adhere to painted metal surfaces, but without affording any potential equalisation.

The total **resistance per person** diverted via the wrist band earthing (grounding) device, measured between the person's hand and the earth (ground) potential must be between 0.75 and 35 MOhm.

The rules "**Technical safety requirements for wrist band earthing (grounding)**" issued by the precision mechanical and electrical engineering industrial accident insurers must be complied with.

Shoes and foot earthing (grounding) straps

Electrically conductive shoes should be worn by persons who mainly work standing up or either standing or sitting in electrostatic discharge (ESD) protection zones, particularly if wrist band earthing (grounding) is impracticable. The standard calls for ESD shoes to record values between 0 and 35 MOhm resistance. However, for antistatic working shoes resistance values between 0.1 and 1000 MOhm are called for, and a through-conducting resistance for protective shoes of 0.1 to 100 MOhm. A lower limit value of not less than 0.1 MOhm must be maintained on account of the contact voltage risk. For this reason the minimum value has been set contrary to the standard at the higher figure of 0.75 MOhm.

° Foot earthing (grounding) straps

Persons working temporarily in ESD risk zones (or for example visitors) must be provided with foot earthing straps.

The total **discharge resistance of each person** by way of these shoes or earthing (grounding) straps, measured between hand and earth (ground) potential, must be between 0.75 and 35 MOhm.

Tools

Tools used in ESD protection zones should if possible be made of **electrostatically conductive** material.

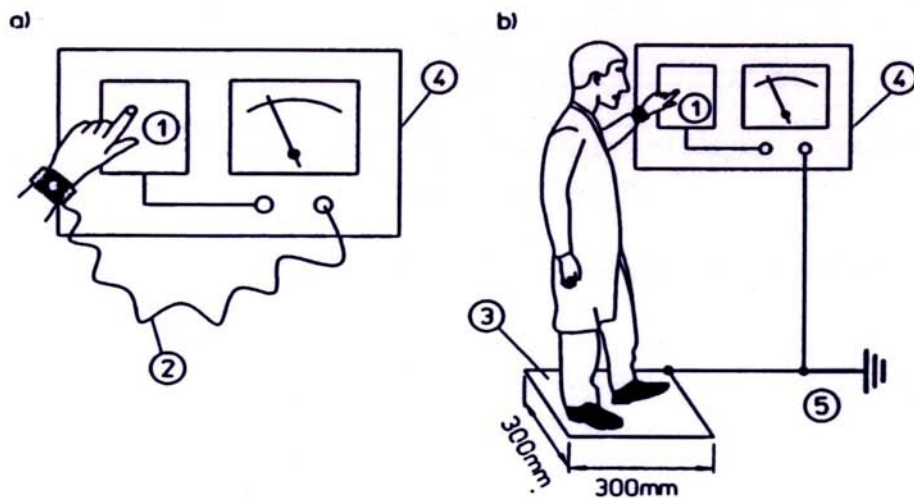

- a If a wrist earthing (grounding) band is worn
- b If ESD protective shoes are worn
- 1 Hand contact plate
- 2 Wrist earthing (grounding) band
- 3 Footplate
- 4 Resistance measuring device
- 5 ESD earthing (grounding) system

Individual component installation sequence (electrical circuit) from bottom to top

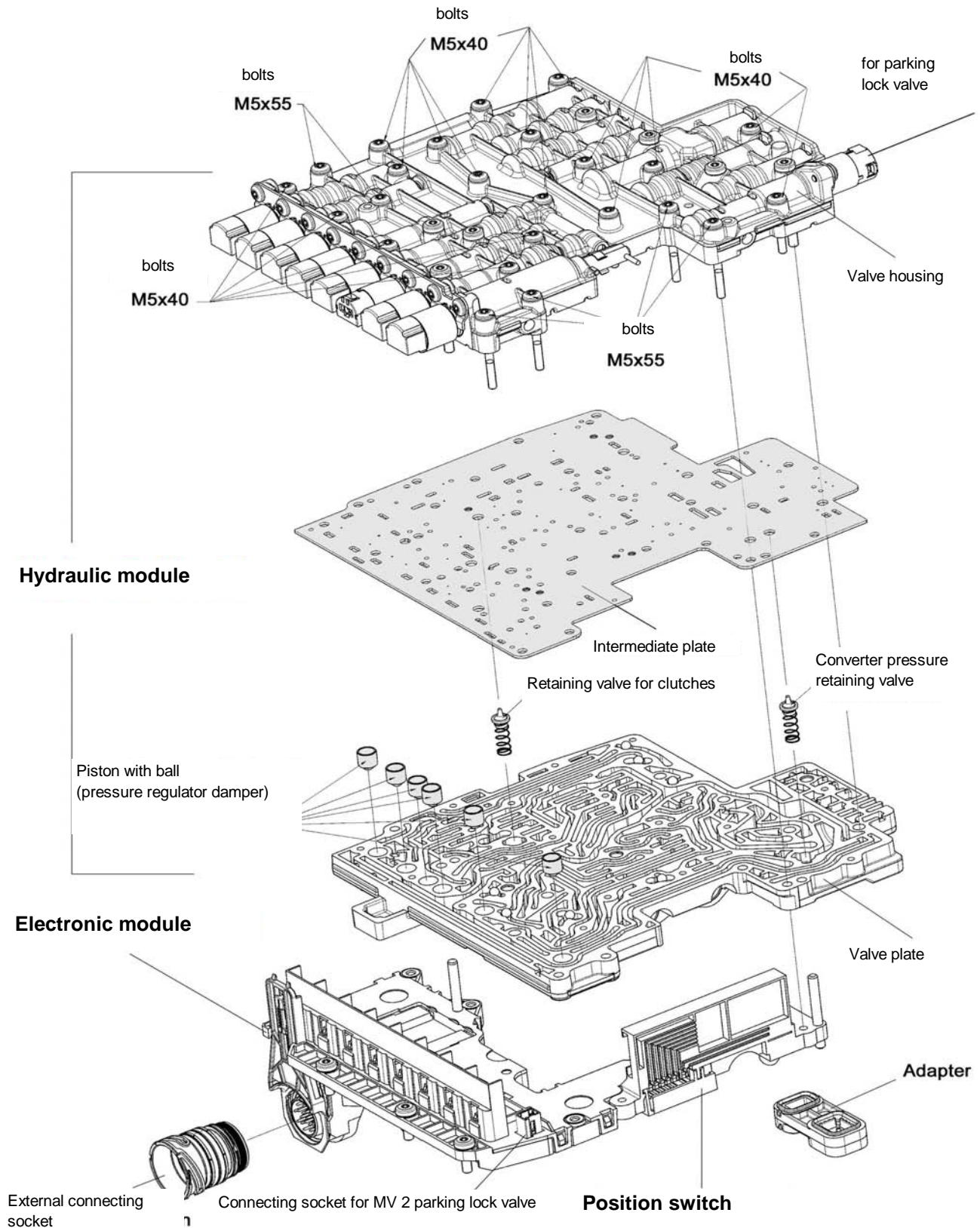

Individual component assembly sequence (M shift) from bottom to top

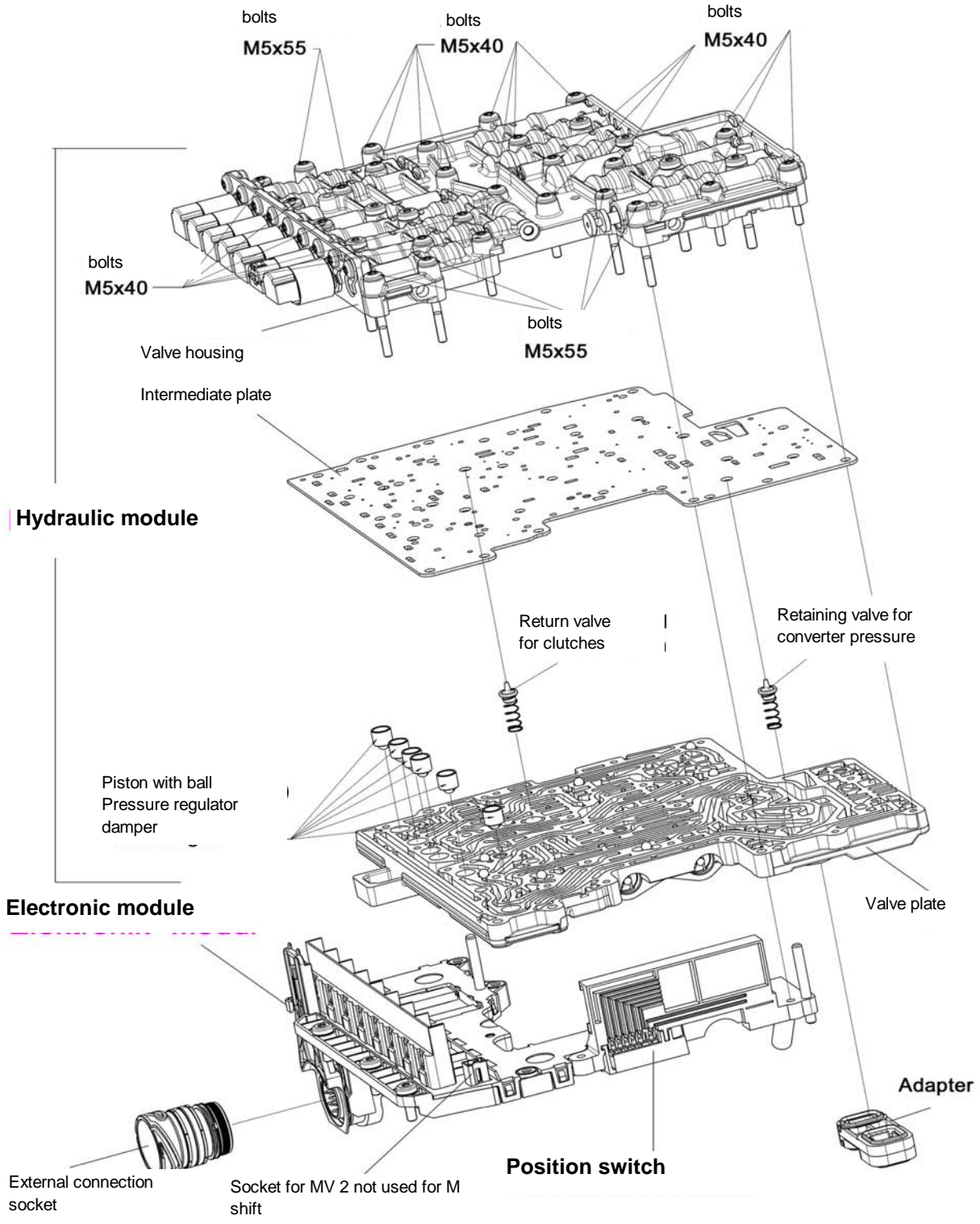

Electrical circuit

When installing the two modules

(hydraulic and electronic)

make sure in particular that the piston of the parking lock cylinder is connected to the position switch - see sketch.

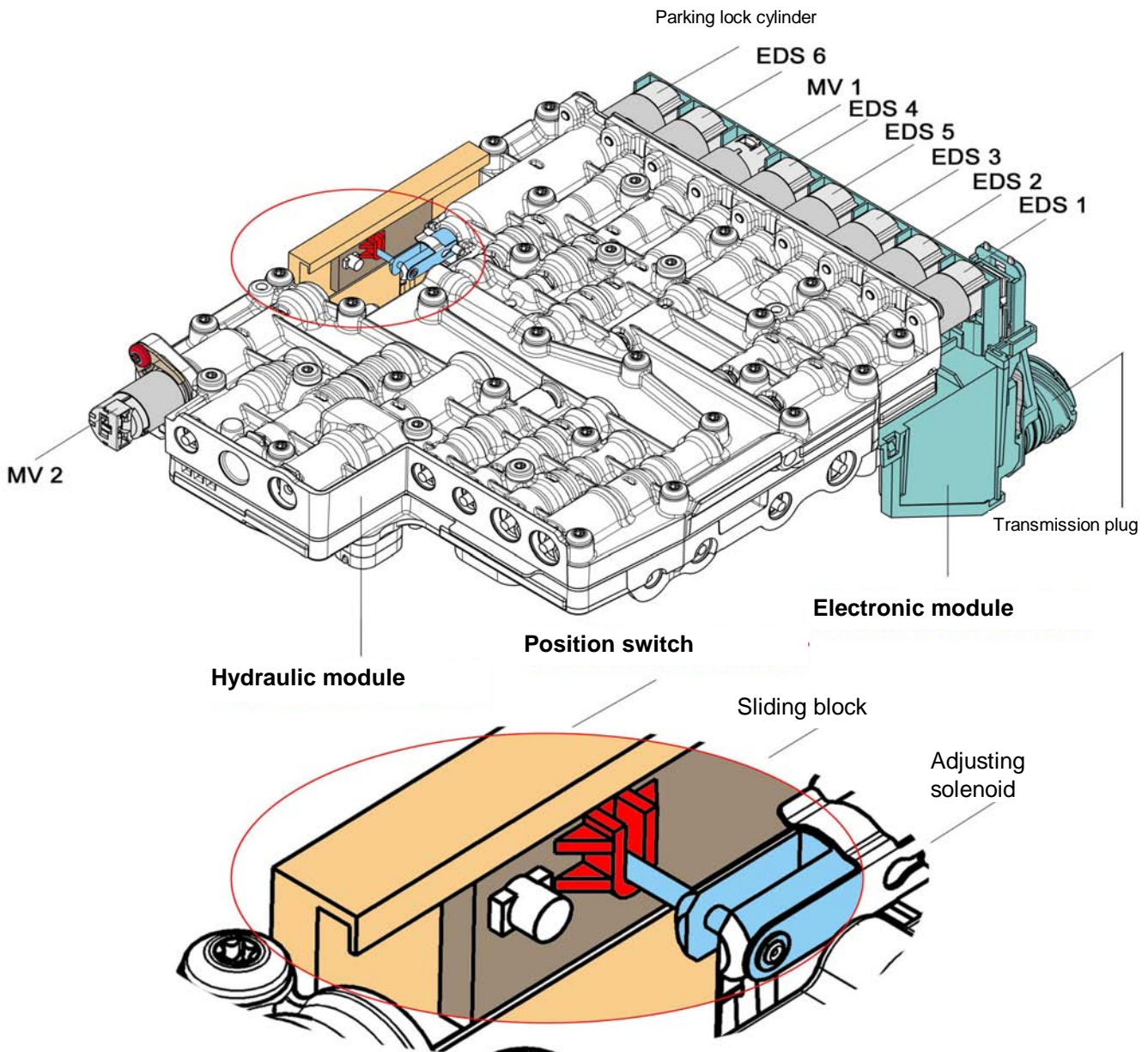

M shift

When installing the two modules

(hydraulic module and electronic module)

make sure in particular that the selector spool valve is connected to the position switch (see sketch).

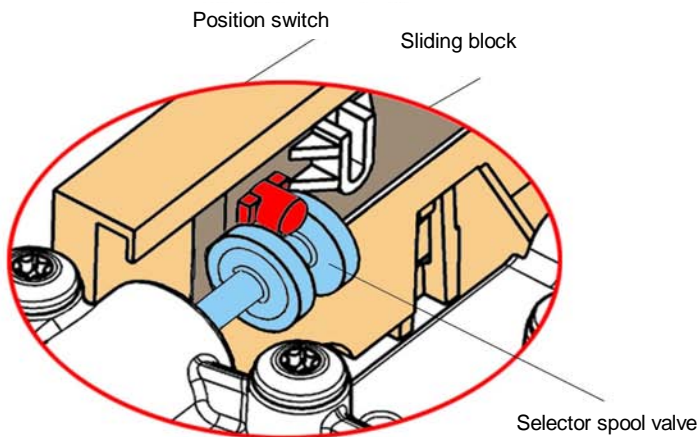
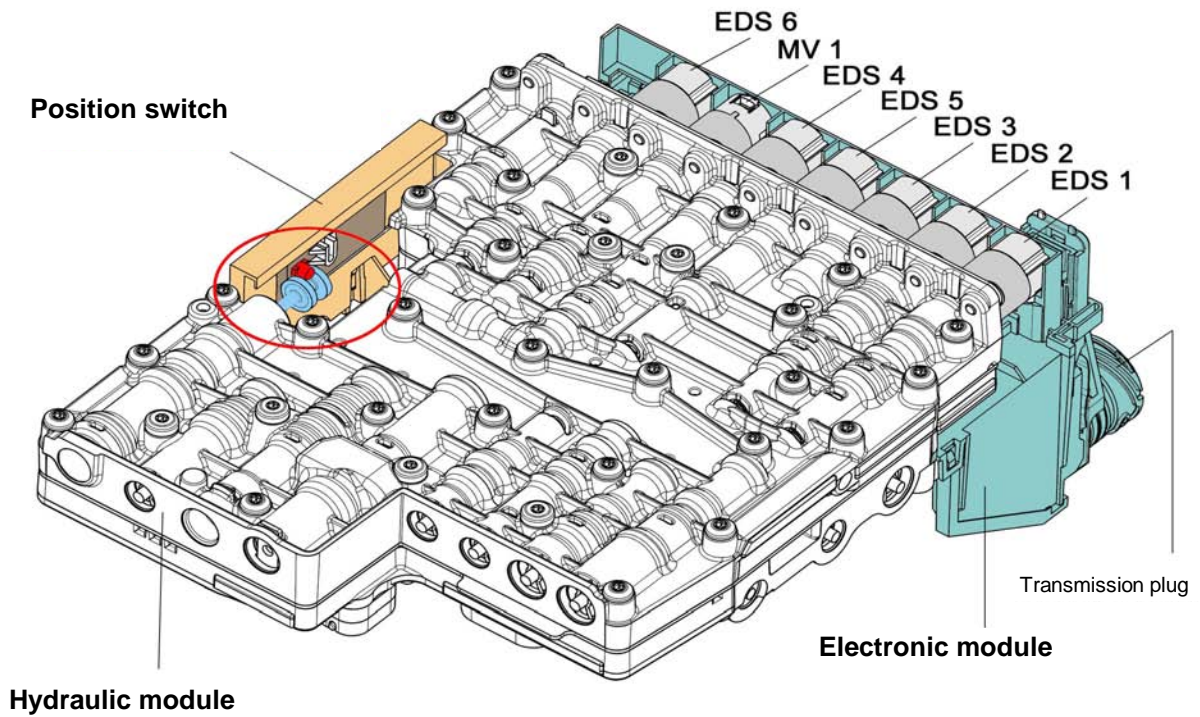

Installed positions of valves in valve housing (E shift)

Ps-Zyl. = Parking lock cylinder
 SHV1 = Selector valve 1
 SHV2 = Selector valve 2
 HV-D = Retaining brake D
 Dr.Red.-V = Pressure reducing valve

HV-B = Retaining valve, clutch B
 HV-A = Retaining valve, clutch A
 MV = Solenoid valve
 EDS = Electronic pressure control

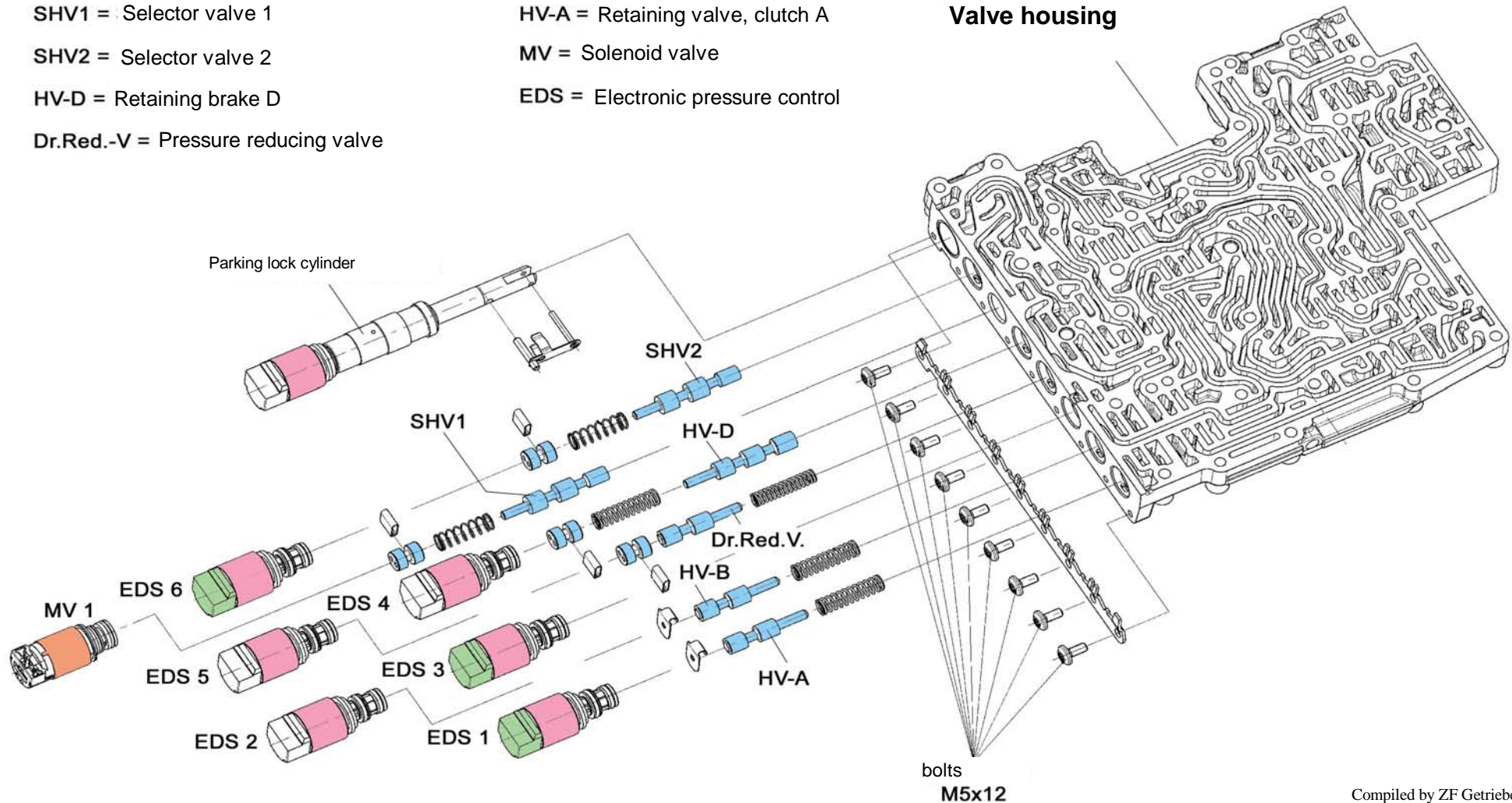

Installed positions of valves in valve housing (M shift)

- SV- Reservoir
- SHV2 = Shift valve 2
- SHV1 = Shift valve 1
- Dr.Red.-V = Pressure reducing valve
- HV- A = Retaining valve, clutch A
- HV- B = Retaining valve, clutch B
- EDS1- 6 = Electronic pressure control 1-6
- MV1 = Solenoid valve 1

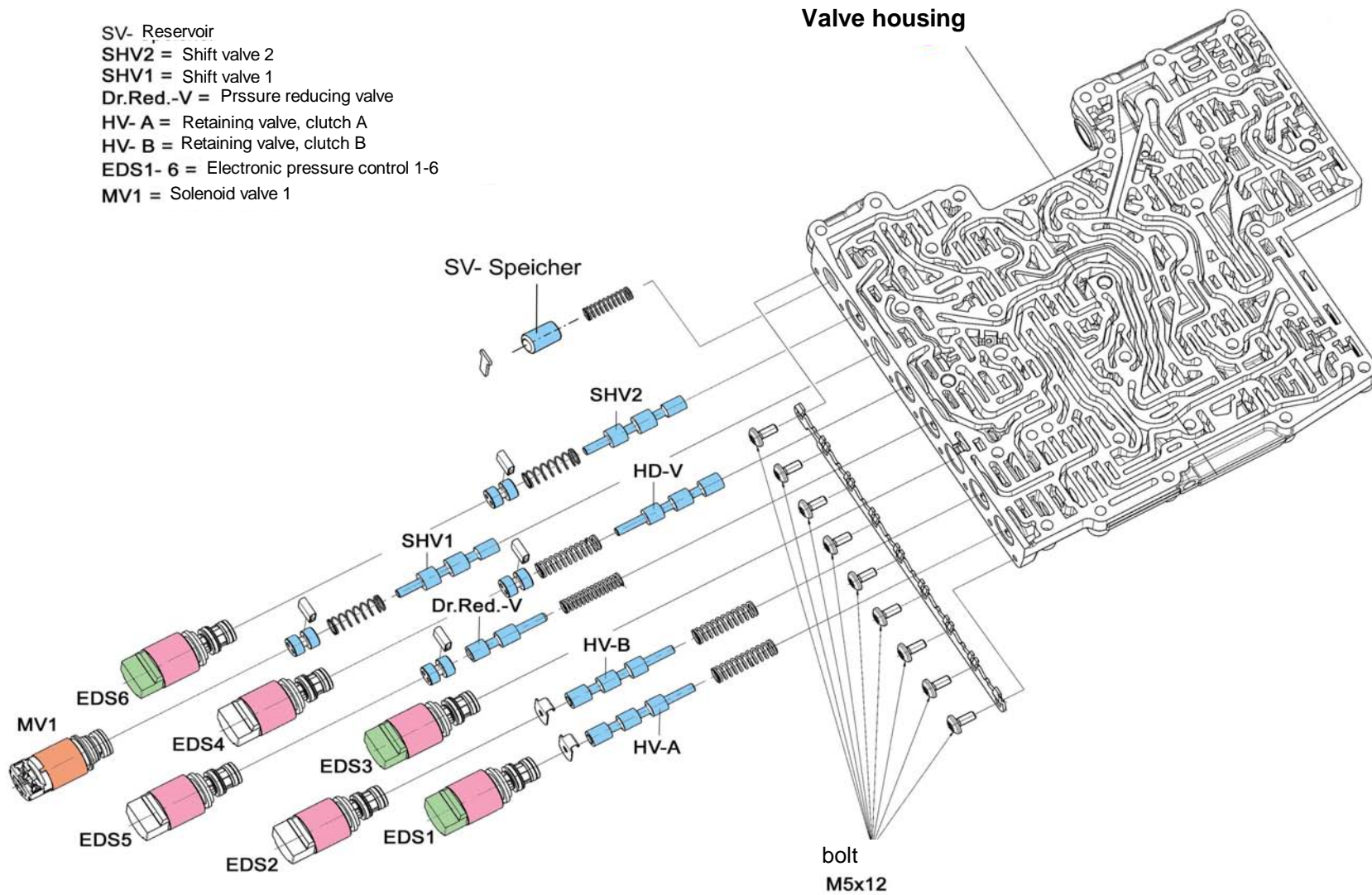

Installed positions of valves in valve housing (E shift)

- MV 2 = Solenoid valve 2
- PS-V = Parking lock valve
- Schm.-V = Lubrikating valve
- WD-V = Converter pressure valve
- Sys.Dr.-V = System pressure valve
- WK-V = Converter lock-up clutch valve
- HV-E = Retaining valve, clutch E
- KV-E = Clutch valve E
- KV-A = Clutch valve A

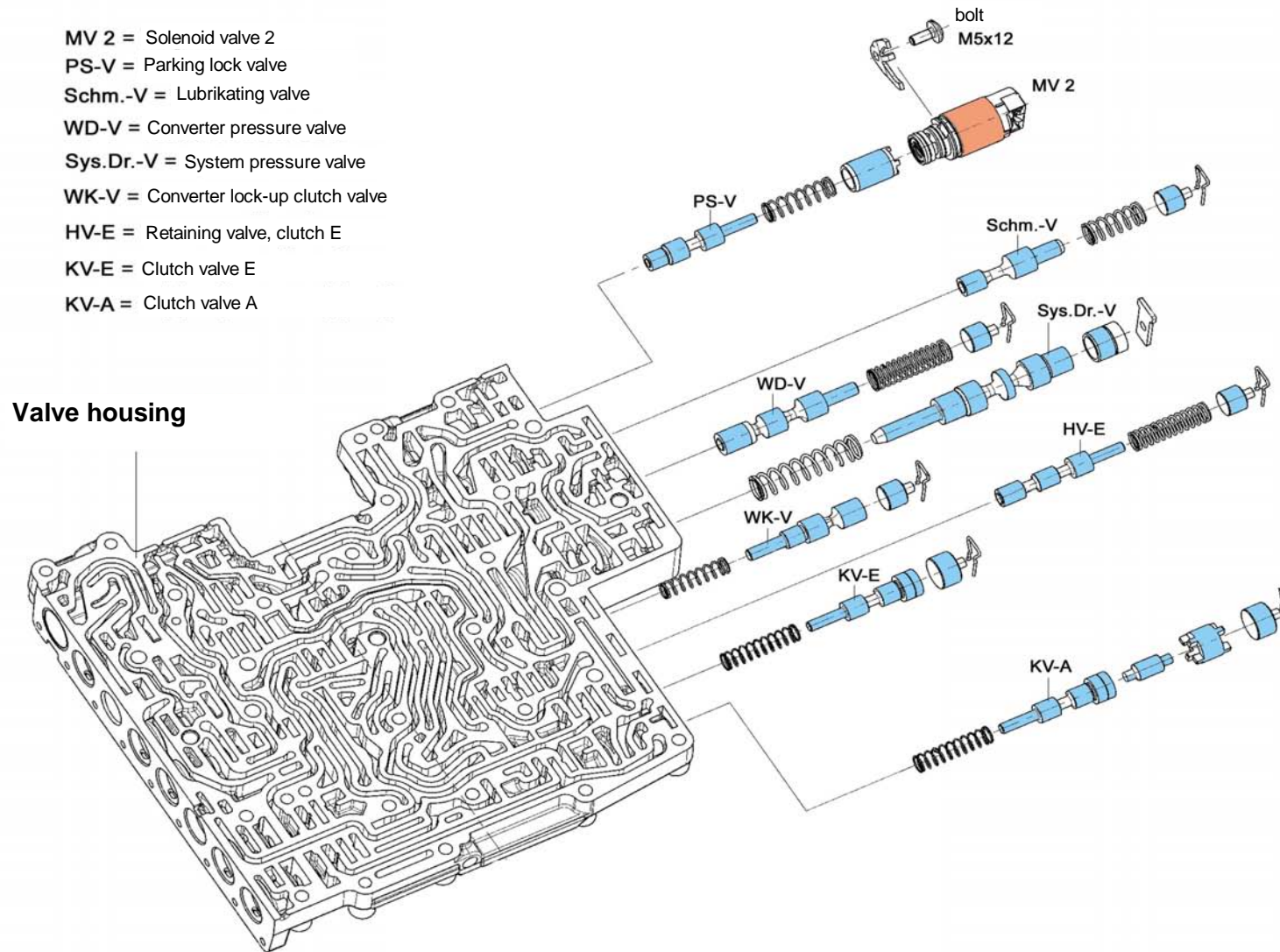

Installed positions of valves in valve housing (M shift)

- WS** = Selector spool valve
- Schm.-V** = Lubricating valve
- WD-V** = Converter pressure valve
- Sys.Dr.-V** = System pressure valve
- WK-V** = Converter clutch valve
- HV-E** = Retaining valve, clutch E
- KV-E** = Clutch valve E
- KV-A** = Clutch valve A

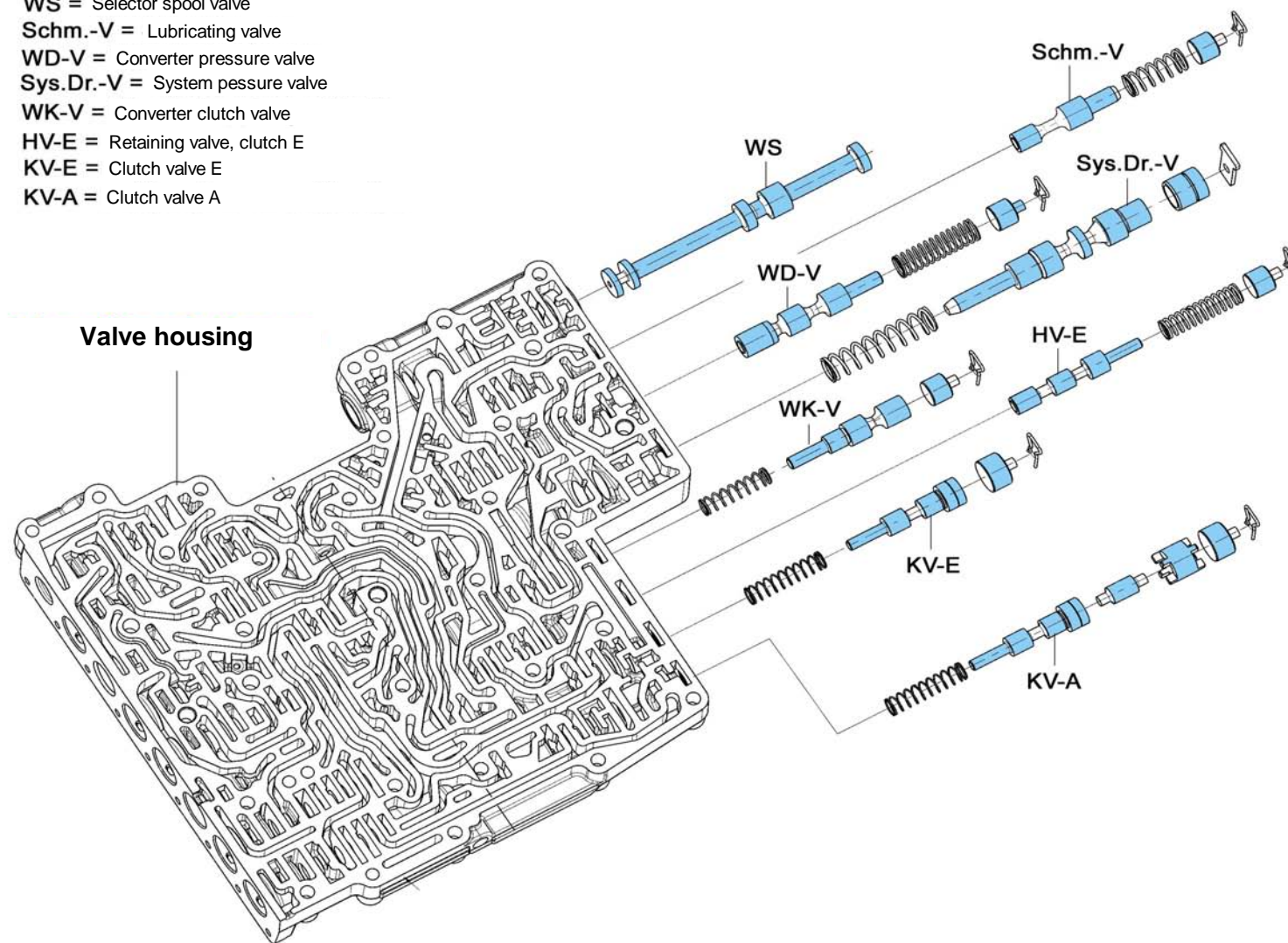

Installed position of valves in valve plate (E shift)

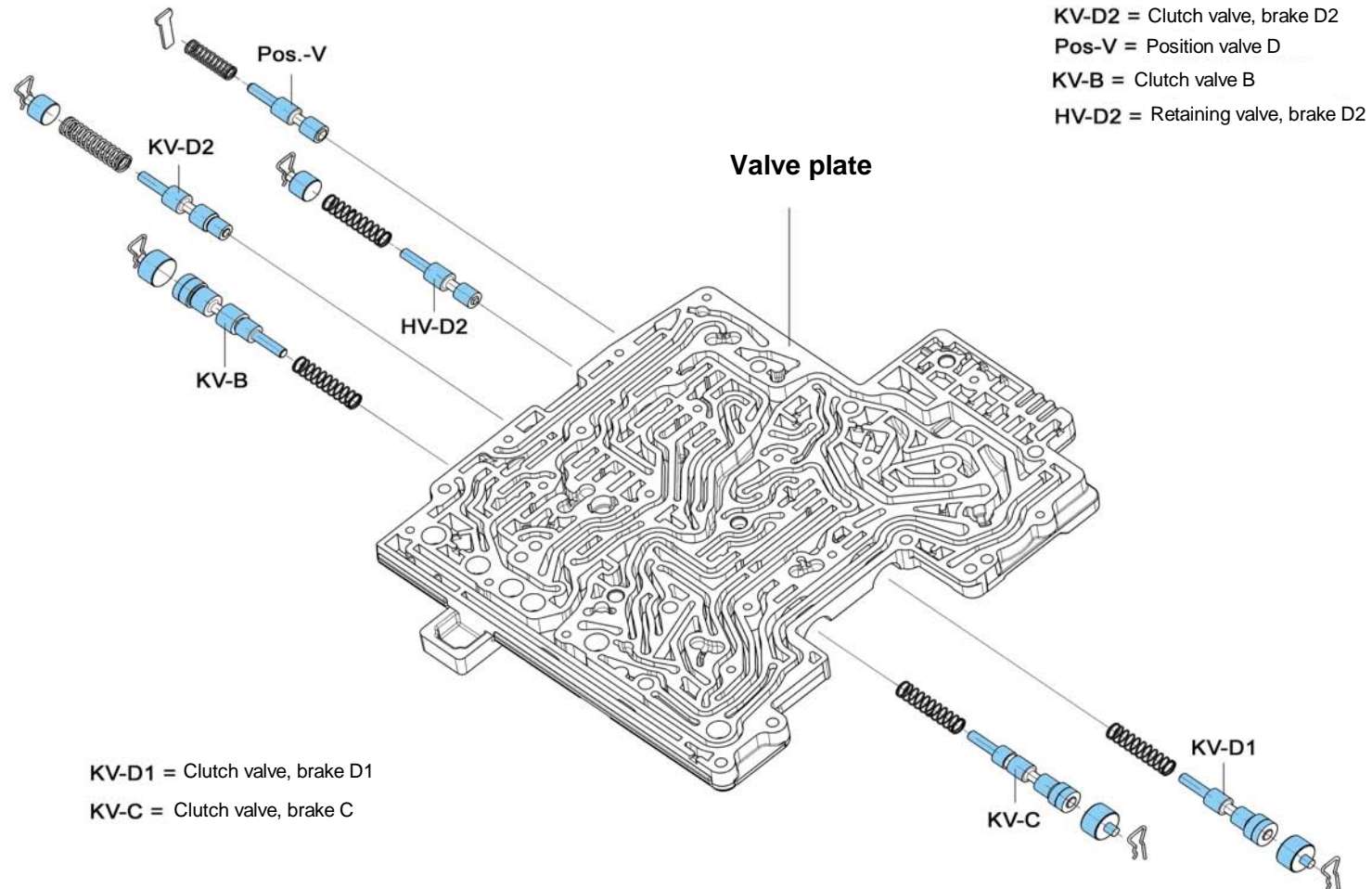

KV-D2 = Clutch valve, brake D2
Pos-V = Position valve D
KV-B = Clutch valve B
HV-D2 = Retaining valve, brake D2

KV-D1 = Clutch valve, brake D1
KV-C = Clutch valve, brake C

Installed positions of valves in clutch plate (M shift)

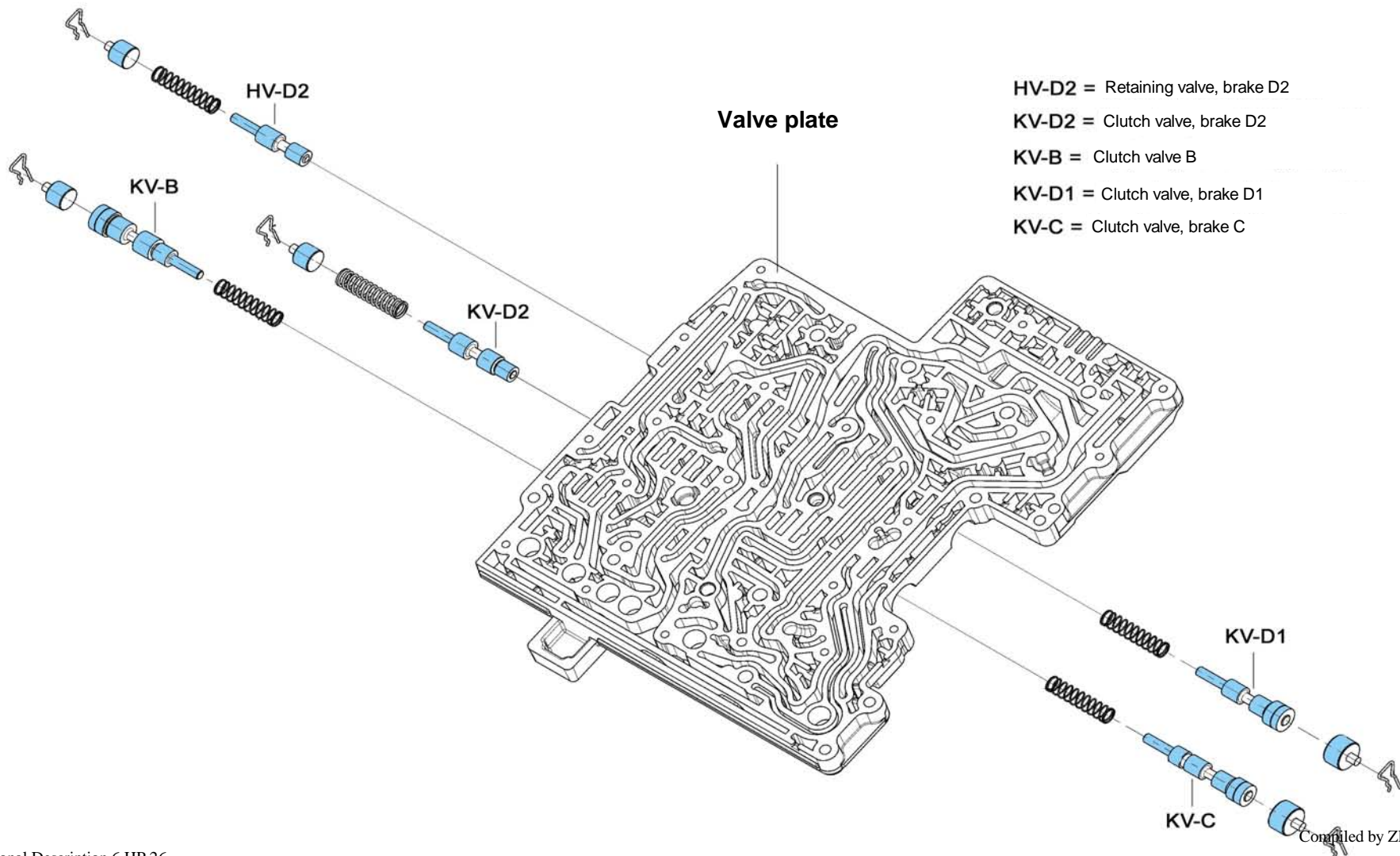

Brief description of valves (M and E shift)

Selector spool valve (WS) only with M shift

The selector spool valve is used by the driver to select the direction of travel (forward or reverse), the parking lock position or neutral.

Parking lock cylinder (PS- ZYL) only with E shift

The parking lock is engaged electrically by the parking lock cylinder. For a detailed description, see page 22, "Parking lock".

Parking lock valve (PS- V) only with E shift

The purpose of the parking lock cylinder is to shift the parking lock cylinder to the Nneutral or Park positions. The PS-V is actuated by solenoid valve 2.

MV2 active = neutral position

MV2 inactive = park position

Shift valve 1-SHV1 (emergency-run valve)

The task of this valve is to keep the gear actually selected in use if the power should fail while driving. If the car is restarted and the EGS is in the emergency program (no power at E actuators), a predetermined gear is selected.

The shift valve's self-sustaining function is cancelled if the car is restarted, but re-activated by the EGS.

Shift valve 2 (SHV2)

Shift valve 2 is actuated by solenoid valve 2 and supplies system pressure to operate the relevant clutches.

Retaining valves, brake D, clutches A,B,E, (HV- D, HV-A, HV- B, HV-E)

The retaining valves actuate the clutch valves, that is to say the regulating function of the clutch valve is shut down by the retaining valve during the shift at the appropriate time, so that clutch pressure rises to the system pressure. Both valves (clutch and retaining valves) are regulated by the corresponding pressure regulator (EDS).

Clutch valves-Clutches A, B, E, brake C, D1,D2, (KV- A, B, E, C, D1, D2)

The clutch valves are variable pressure reducing valves. They are controlled by the relevant electronic pressure control valve (EDS) and determine clutch pressure during the shift.

Pressure reducing valve (Dr.Red.- V)

The pressure reducing valve lowers system pressure to app. 5 bar, which is then applied to the downstream pressure control circuits (EDS1- 6) and solenoid valves (MV1- 2). The pressure control circuits and solenoid valves need a constant feed pressure if they are to function correctly.

Lubricating valve (Schm.- V)

The lubricating valve reduces and guarantees the pressure needed for lubrication. It also imposes an upper limit on the pressure.

Converter pressure valve (WD- V)

The converter pressure valve reduces system pressure and guarantees the pressure needed for the converter. It also limits maximum converter pressure, to prevent the converter from expanding. If EDS 6 is actuated, the oil passage behind the converter lock-up piston is vented.

System pressure valve (Sys.Dr.- V)

The system pressure valve is a variable pressure limiting valve and regulates the oil pressure built up by the primary pump. Excess oil is returned to the pump intake port.

Converter lock-up clutch valve (WK- V)

The converter lock-up clutch valve is controlled jointly with the converter pressure valve by the electronic pressure control (EDS 6). When it operates, the direction of oil flow is reversed. As the converter pressure valve vents the piston chamber behind the converter lock-up clutch, the space in front of it is charged at system pressure via the converter lock-up clutch valve.

Position valve D (Pos.-V) only with E shift

The position valve takes the place of the selector spool valve and diverts system pressure to regulate the individual clutches and brakes. The position valve is actuated by solenoid valve 1 (E shift) and held in the relevant gear by clutches A and E.

Solenoid valves 1, 2 (MV1, MV2)

The hydraulic module contains one (M shift) or two (E shift) 3/2-way solenoid valves, that is to say these valves have 3 unions and 2 switching positions. The solenoid valves are actuated by the electronic transmission control system and have two functions (open or closed), They are used to switch the positions of valves.



Electronic pressure control valves 1- 6 (EDS1- 6)

The electronic pressure control valves convert an electric current into a proportional hydraulic pressure. They are energised by the electronic module and actuate the valves belonging to the relevant switching elements.

Two types of electronic pressure regulator are installed:

1. Pressure regulator with rising characteristic (EDS1, 3, 6- green cap)
2. Pressure regulator with falling characteristic (EDS2, 4, 5- black cap)

Pressure regulator with rising characteristic (0 mA = 0 bar / 700 mA = 4.6 bar))

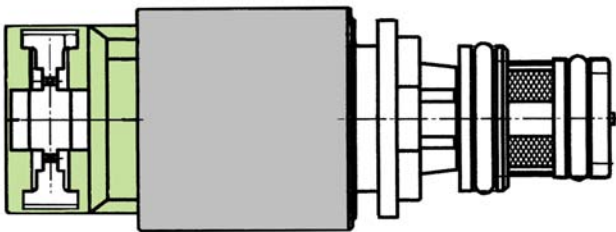

Technical data:
 Pressure range 0 - 4.6 bar
 Operating voltage 12 V
 Resistance at 20 °C 5.05 Ohm

Pressure regulator with falling characteristic (700 mA = 0 bar / 0 mA = 4.6 bar)

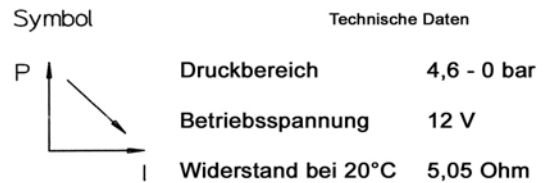
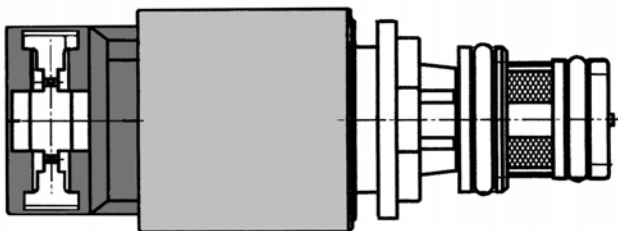

Technical data:
 Pressure range 4.6 - 0 bar
 Operating voltage 12 V
 Resistance at 20 °C 5.05 Ohm

Positions of pressure unions (electrical circuit)

- For: System pressure
Converter lock-up clutch engaged
Converter lock-up clutch released
Oil pressure in cooler line
Clutch A
Clutch B
Clutch E
Brake C
Brake D1
Brake D2

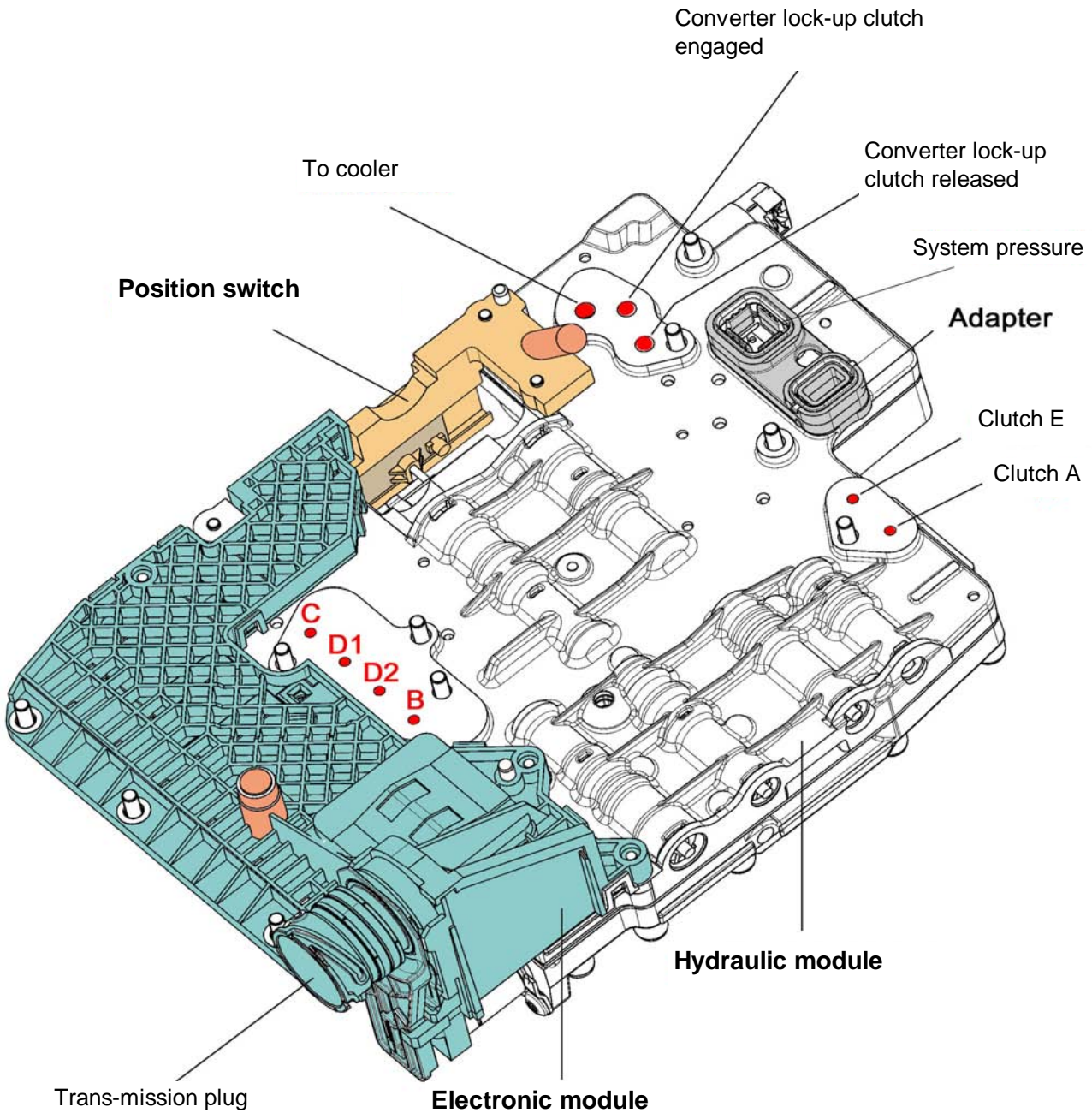

Position of pressure unions (M shift)

- For: System pressure
 Converter lock-up clutch engaged
 Converter lock-up clutch released
 Oil pressure in cooler line
 Clutch A
 Clutch B
 Clutch E
 Brake C
 Brake D1
 Brake D2

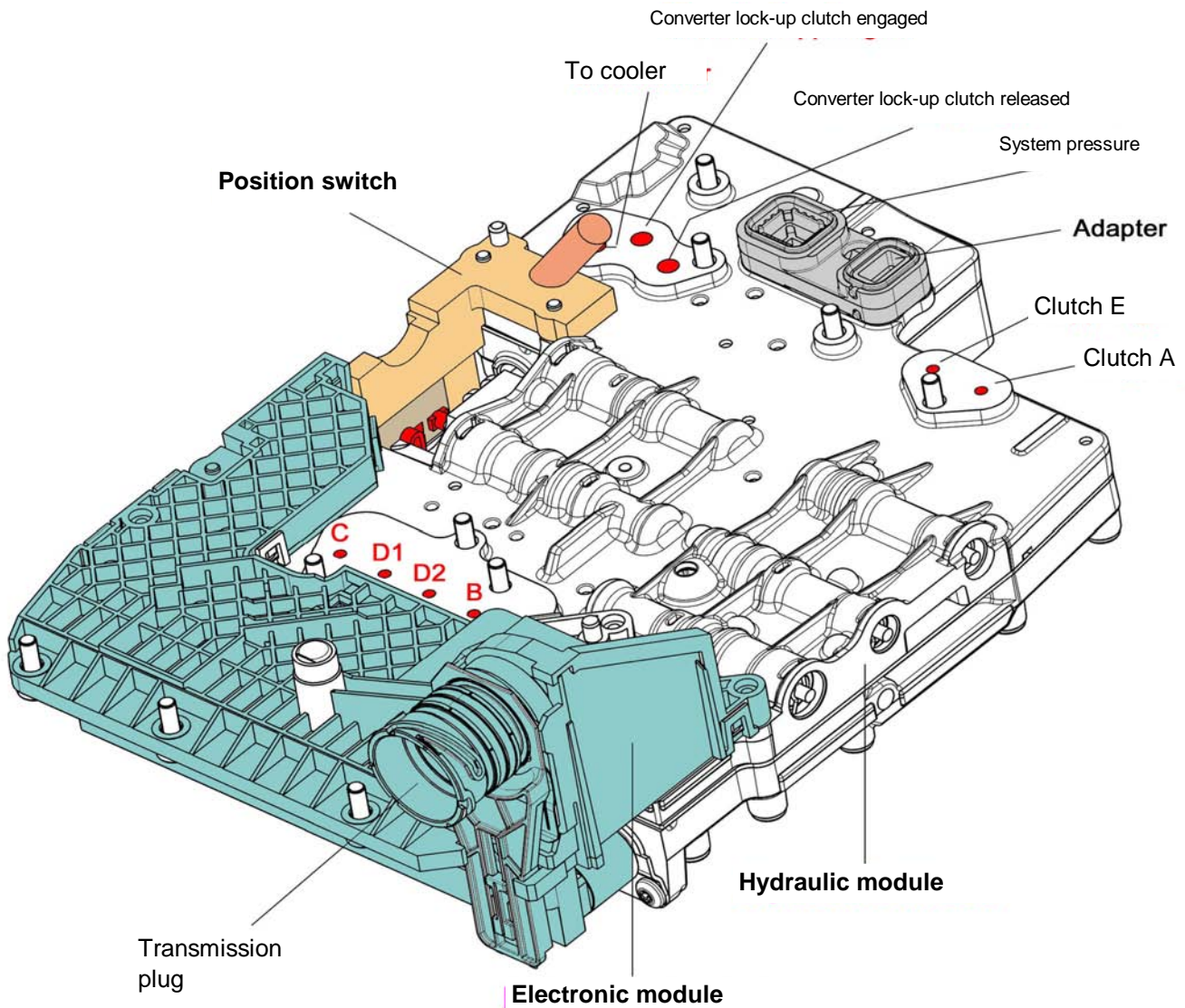

Positions of pressure unions on transmission housing

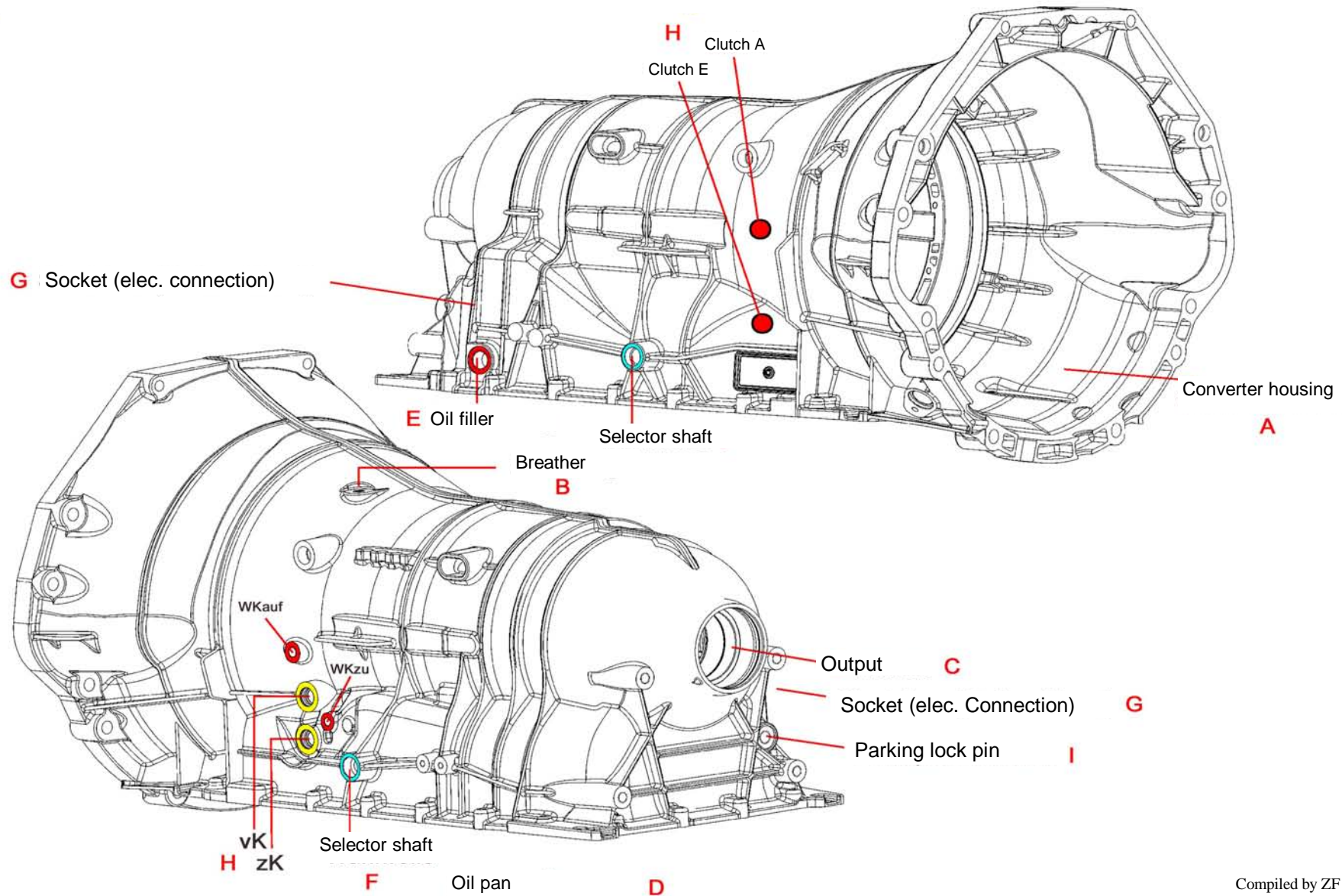

Position of pressure unions on transmission housing

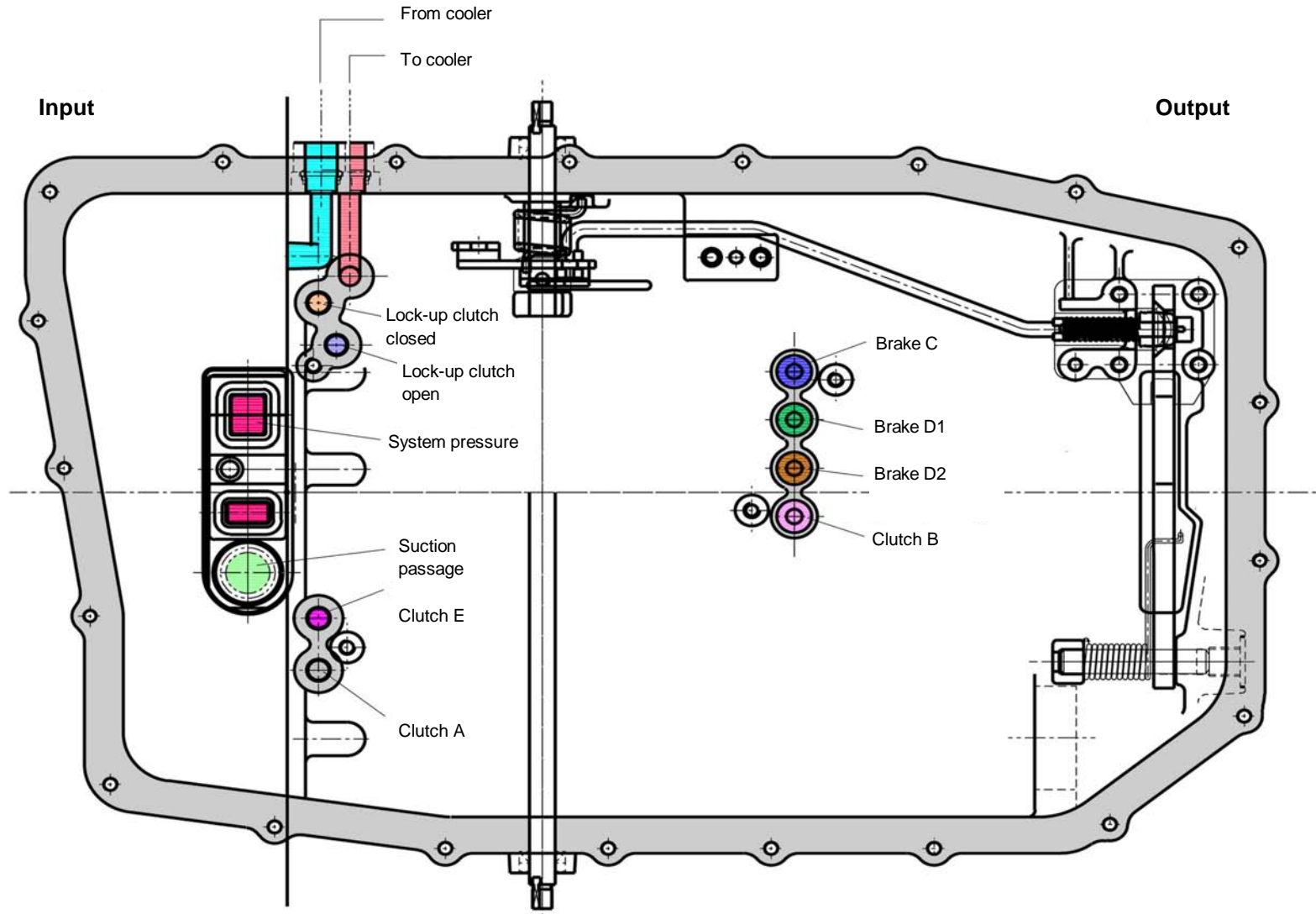

Threaded connections for components (electrical circuit)

M5 screws (electronic module to hydraulic module) 6x
 M6 screws (complete Mechatronik to transmission housing) 10x
 M5 screws (hydraulic module) 18x

- Schrauben M5 (Elektronik-Modul an Hydraulik-Modul) 6x
- Schrauben M6 (Mechatronik kpl. an Getriebegehäuse) 10x
- Schrauben M5 (Hydraulik-Modul) 18x

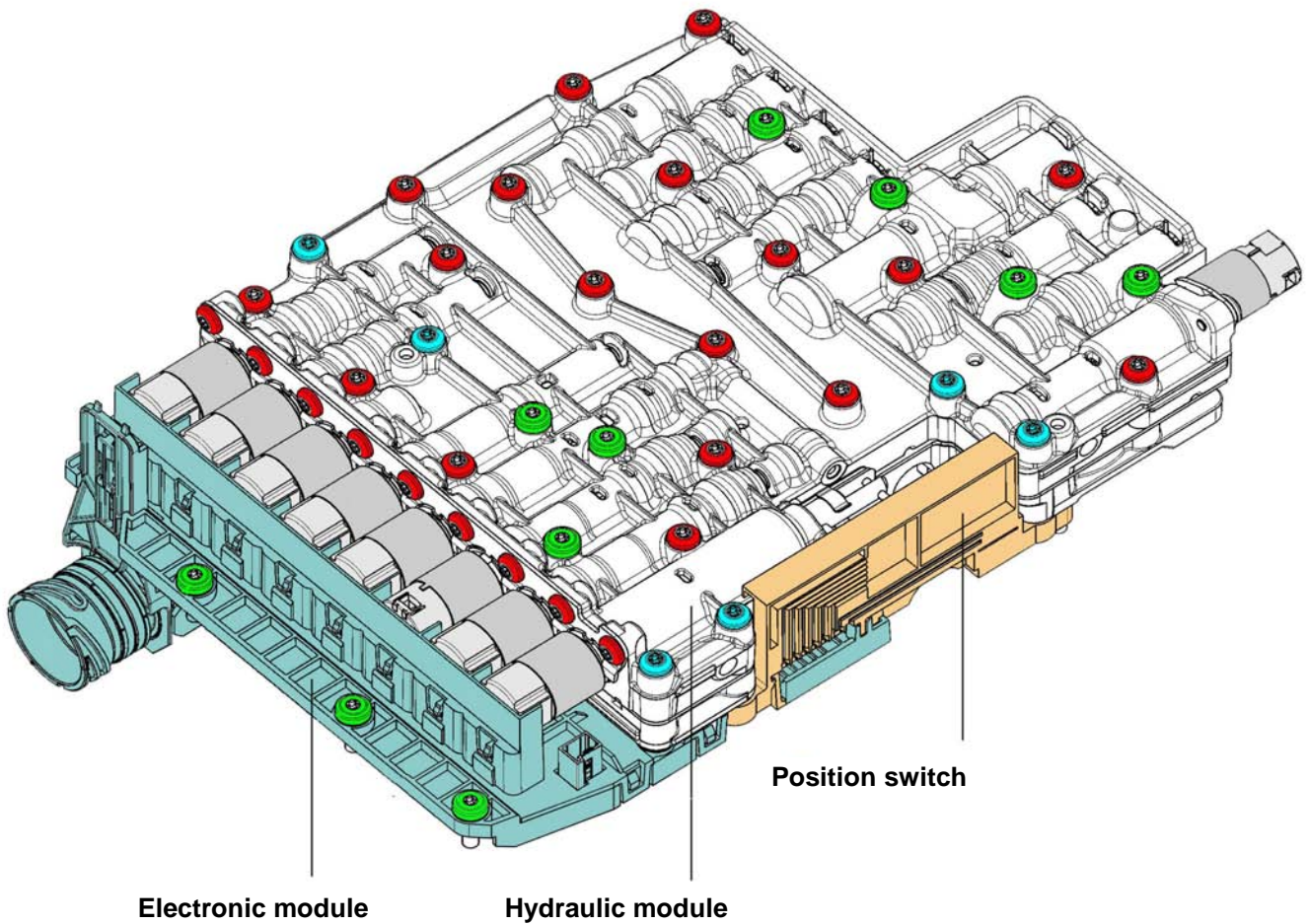

Threaded connections for individual components (M shift)

M5 screws (electronic module to hydraulic module) 6x
 M6 screws (complete Mechatronik to transmission housing) 10x
 M5 screws (hydraulic module) 20x

- Schrauben M5 (Elektronik- Modul an Hydraulik- Modul) 6x
- Schrauben M6 (Mechatronik kpl. an Getriebegehäuse) 10x
- Schrauben M5 (Hydraulik- Modul) 20x

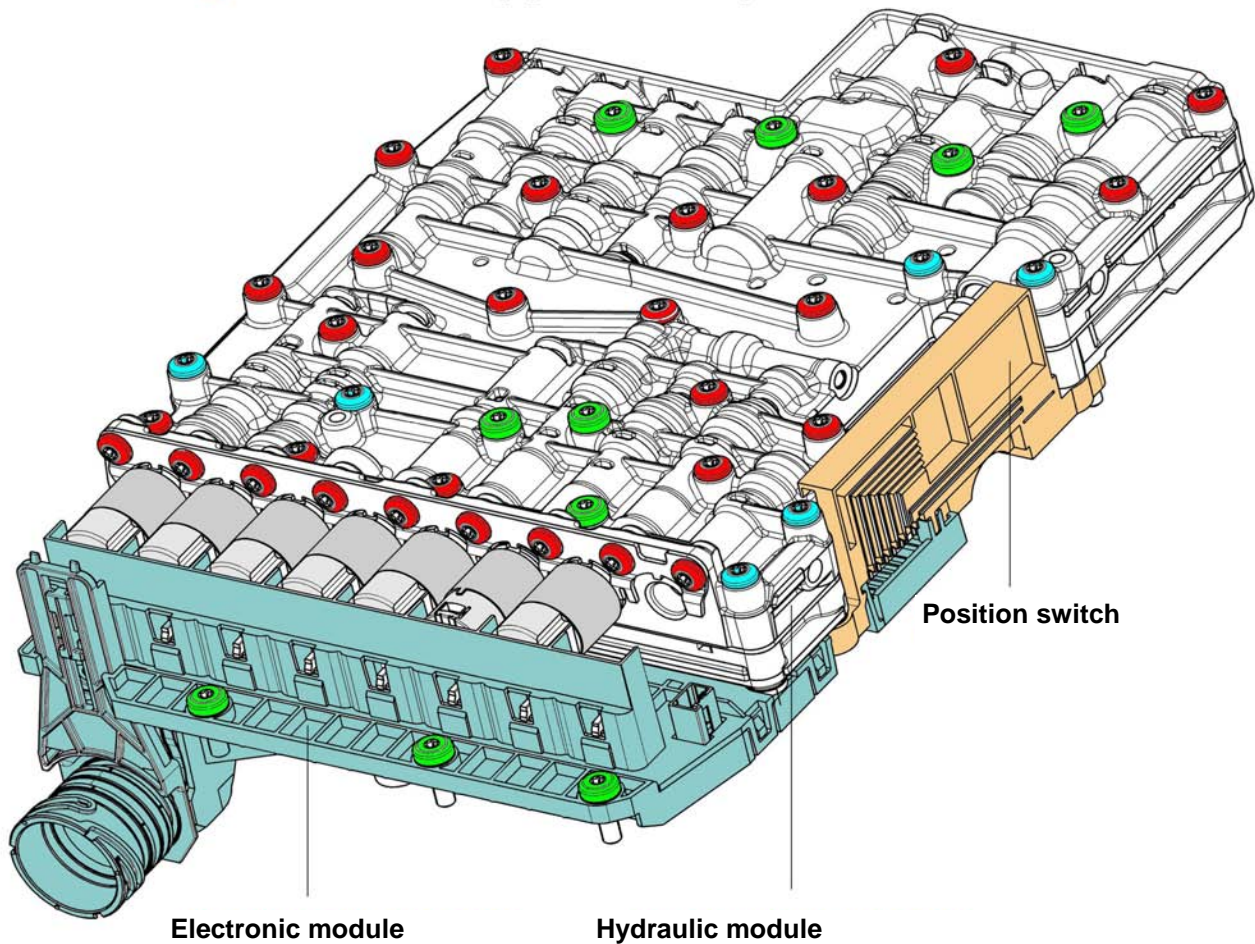

Electronic module (transmission control)

Electronic module

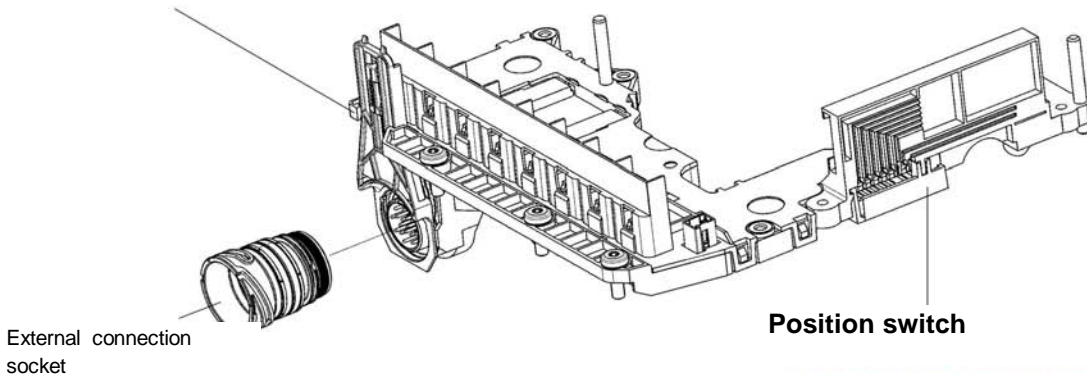

Mechatronik, complete

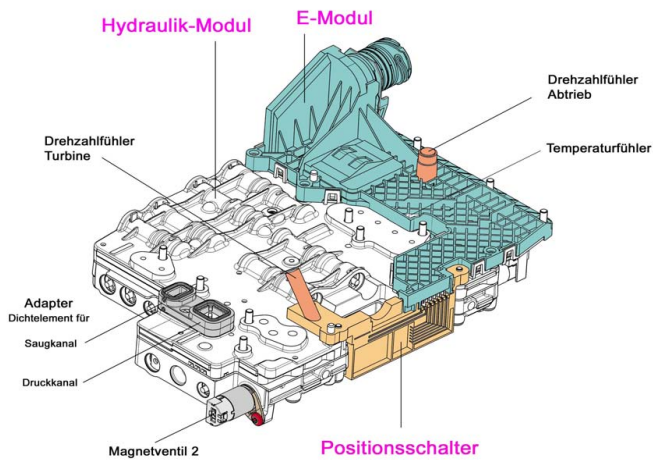

The two speed sensors for the turbine and output speeds, the thermo-sensor and the position switch are **permanently** integrated at the E module.

The electronic module (electronic transmission control, EGS) processes signals from the transmission, the engine and the vehicle.

From the signal inputs and the memorised data the control program computes the correct gear and converter lock-up clutch setting and the optimum pressure settings for gear shift and lock-up clutch control.

By means of special output-side modules (power output stages, current regulator circuits), the EGS controls the solenoid valves and pressure regulators and thus influences the hydraulics of the automatic transmission.

In addition, the amount and duration of engine interventions are supplied to the engine management by way of the CAN bus.

CAN and series line

Signals are always transmitted between the individual items of equipment by the CAN bus.

Controller Area Network (motor-vehicle bus system)

For reasons of availability, signal transmission between SZL and EGS not only uses the bus line but also an additional unidirectional series line from SZL to EGS.

The series line must maintain the same security standard as the CAN link.

The CAN bus is provided with mechanisms (check sum etc.) that ensure the highly reliable transfer of data.

If data are transmitted from one bus line to another, e.g. from K- CAN to P- CAN, the central gateway module forms a link in the data transfer chain.

Schematic communication diagram

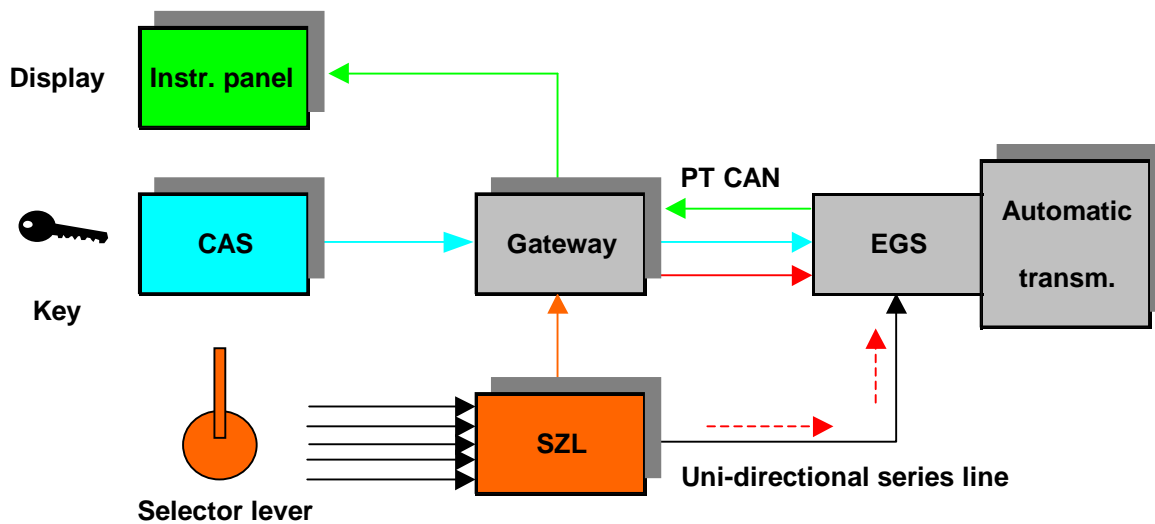

The data that the transmission control unit needs to select the correct gear, for example

[Injection time, engine speed, throttle butterfly angle, engine temperature, engine interventions](#)

are transmitted by the PT CAN bus to the transmission control unit. The solenoid valves and pressure regulating valves are actuated directly from the Mechatronik module.

Signals that can be transmitted via the PT CAN bus to the EGS control unit and thence to other control units are:

Signals	Transmitter	Receiver
Transmission selector switch	SZL	EGS
Terminal status	CAS	EGS
Central locking	CAS	EGS
Transmission data	EGS	CAS
Engine data	DME / DDE	EGS
Wheel rotating speeds	DSC	EGS
Braking requirement	EMF	EGS
Transmission data display	EGS	Instr. panel
Check Control message	EGS	Instr. panel
Torque requirement	EGS	DME
Operating voltage	Power module	EGS
Stationary consumers	EGS	Power module

Transmission turbine and output speeds are detected by Hall-effect sensors, which transmit the values directly to the Mechatronik module.

In the same way the position switch signal is supplied directly to the E module.

The ability to program the transmission control units by flash code is also available here.

The programming procedure is largely based on DME programming, but modified to suit the operations performed by the transmission control units.

The transmission control unit's processor has a 440 kB internal flash memory.. Of this capacity, approx. 370 KB are occupied by the basic transmission program. The remainder, approx, 70 kB, is used to store vehicle-specific application data.

Pressure adaptation takes place automatically during the journey.

After exchange or repair work on the automatic transmission, the pressure adapter must be reset with a suitable tester. After that it is best to carry out a test run and select all the gears in the transmission.

[For further information, see the "ASIS" operating description..](#)

Mechatronik block circuit diagram - 6HP26 BMW

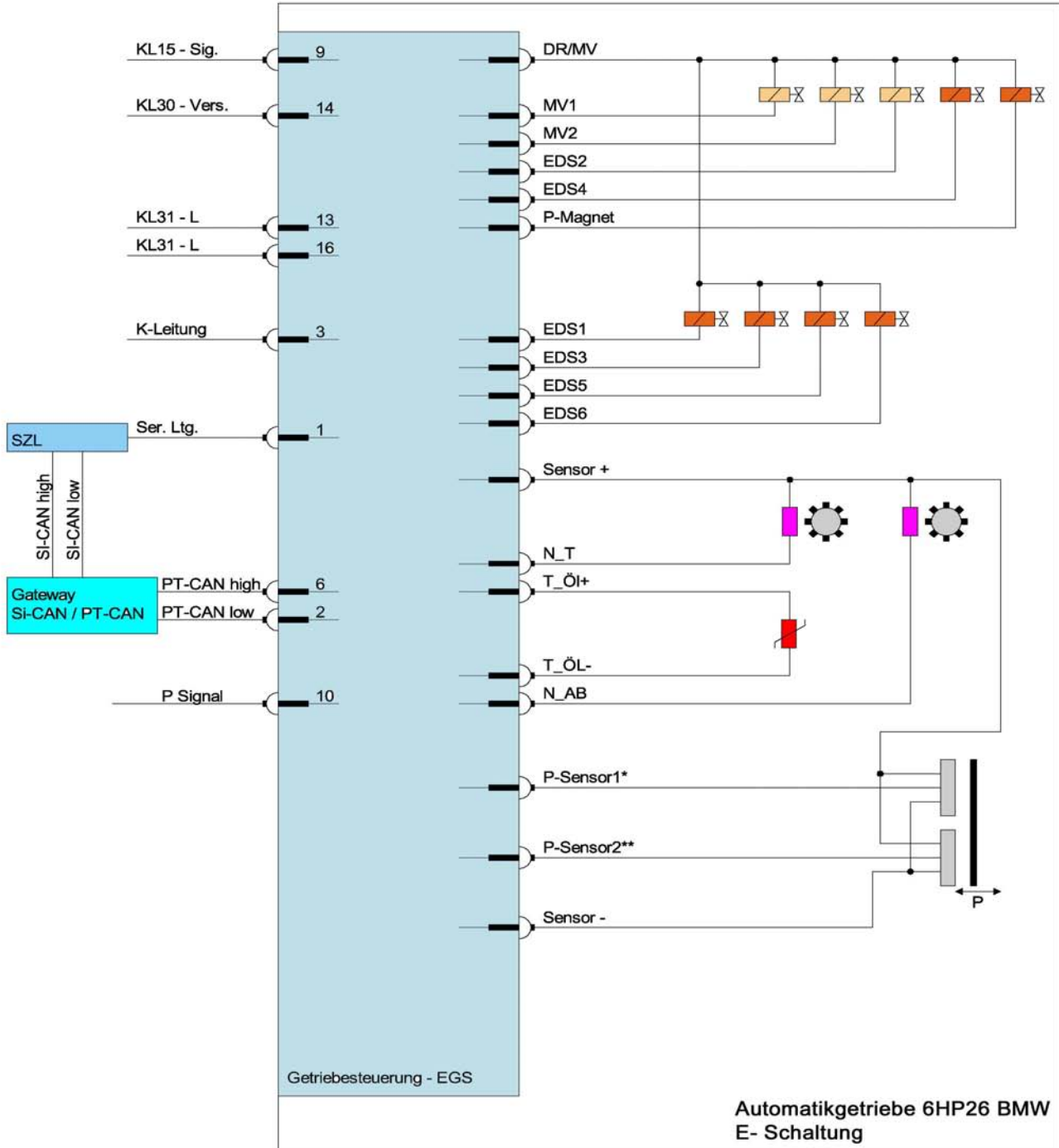

* = L3 vom Positionssensor bei Verwendung des Positionssensors aus 6HP26M
 ** = L4 vom Positionssensor bei Verwendung des Positionssensors aus 6HP26M

Pin assignment at transmission plug - 6HP26 BMW with E-shift

Pin	Assigned to:	Notes:
1	Series line	Availability line from stg. col. switch center
2	CAN L	CAN low
3	ISO K	K line (for example application)
4	not in use	
5	not in use	
6	CAN H	CAN high
7	not in use	
8	not in use	
9	Terminal 15	Wake-up signal, terminal 15
10	P signal	P line for starter inhibit
11	not in use	
12	not in use	
13	Terminal 31-1	Earth (ground)
14	Terminal 30	Permanent positive (EGS supply voltage)
15	not in use	
16	Terminal 31-2	Earth (ground) 2

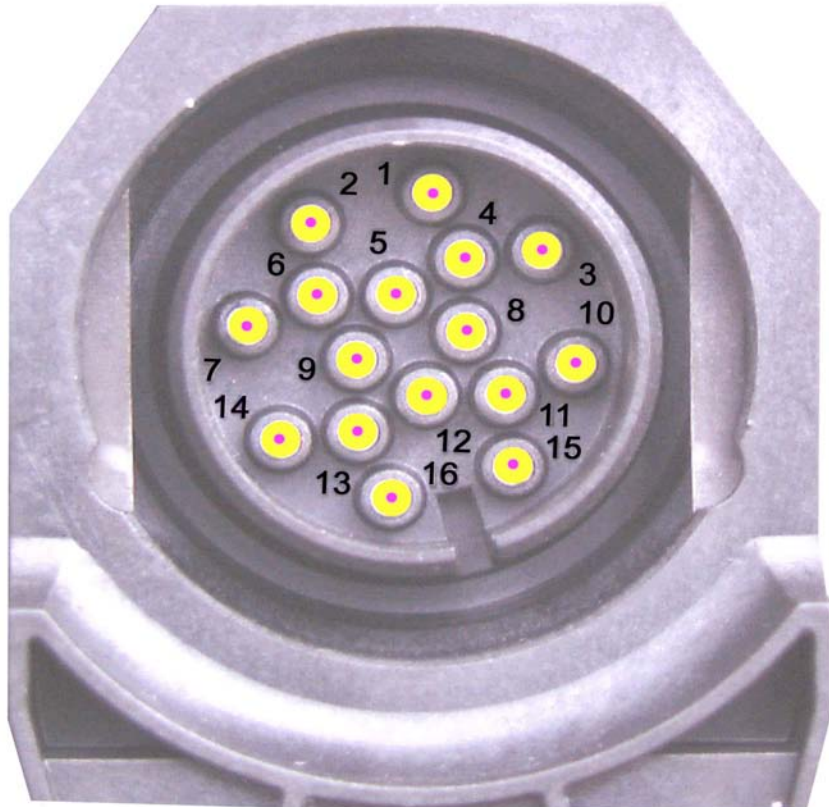

Mechatronik block circuit diagram - 6HP26 BMW

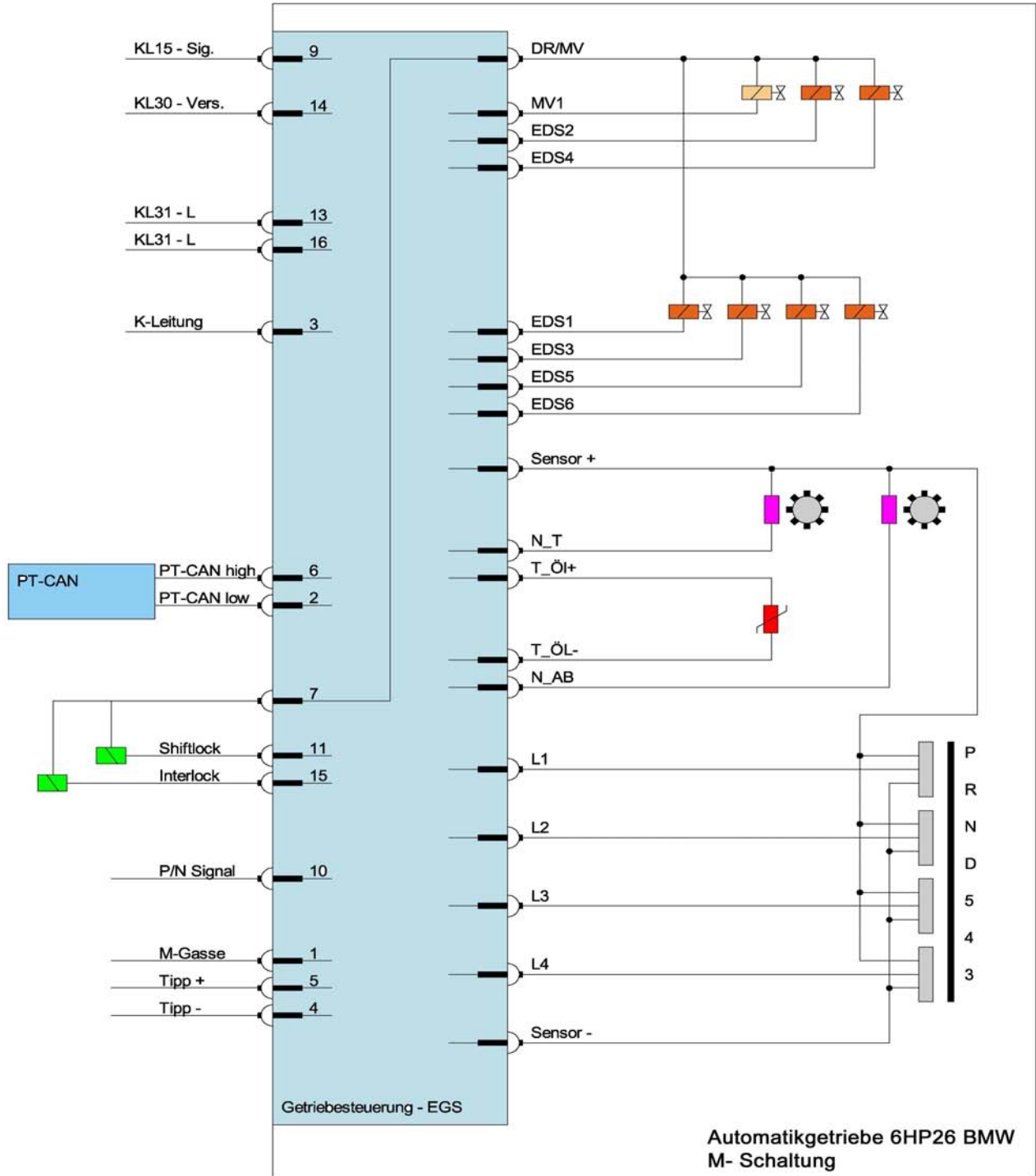

Pin assignment at transmission plug - 6HP26 BMW with M-shift

Pin	Assigned to:	Notes:
1	M gate plane	Manual shift program
2	CAN L	CAN low
3	ISO K	K line (for example application)
4	Touch -	Manual downshift
5	Touch +	Manual upshift
6	CAN H	CAN high
7	Shiftlock	Control signal for Shiftlock and Interlock
8	not in use	
9	Terminal 15	Wake-up signal, terminal 15
10	P signal	P line for starter inhibit
11	Shiftlock	Apply brake before selecting position
12	not in use	
13	Terminal 31-1	Earth (ground)
14	Terminal 30	Permanent positive (EGS supply voltage)
15	Interlock	
16	Terminal 31-2	Earth (ground) 2

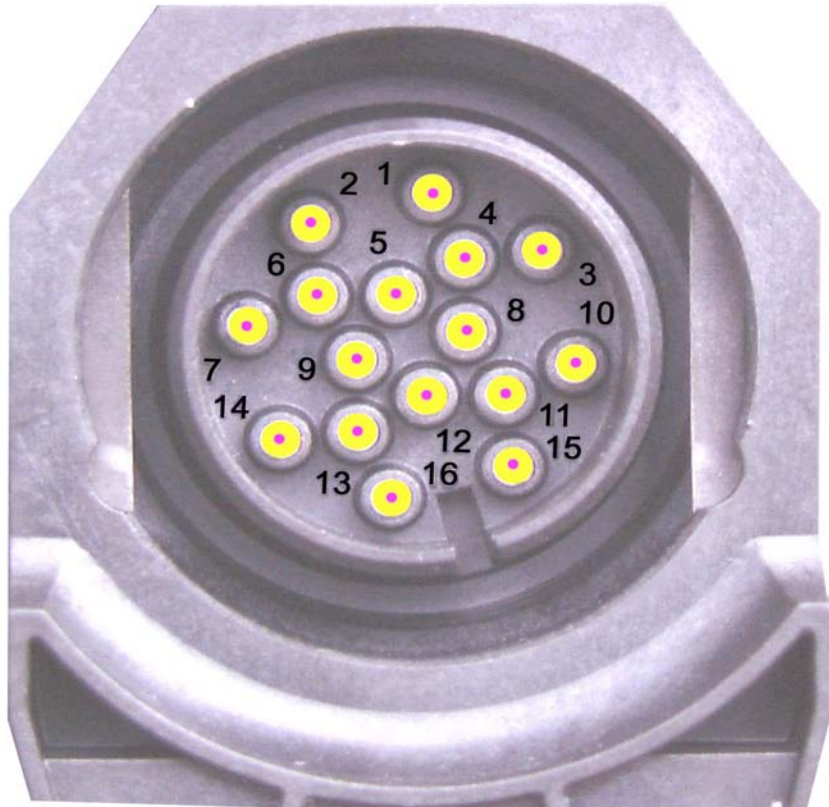

6HP19 passenger-car automatic transmission

Technical data

Transmission type	Passenger-car automatic transmission with 6 forward speeds and 1 reverse Standard layout in vehicle						
Transmission capacities	T max	Engine at 4000 1/min	= 350 Nm				= 400 Nm **
	P max		= 180 kW				= 220 kW
			bei 5500 1/min				bei 6000 1/min
	n max	in 1st - 5th gear	= 7200 1/min				= 6500 1/min
	n max	in 6th gear	= 5600 1/min				= 5600 1/min
	n max	KD- shift	= 6500 1/min				= 6000 1/min
	T max	Turbine forward	= 560 Nm				= 560 Nm
	T max	Turbine reverse	= 300 Nm				= 300 Nm
	Conditions has to be agreed						
Converter	< 230 Nm: W 235 R 2GWK < 310 Nm: W 245 R 2GWK > 310 Nm: W 255 RH 2GWK optional: W 255 RH 2GWK TD						
Gear Ratio	1.	2.	3.	4.	5.	6.	R
	4,17 - 2,34 - 1,52 - 1,14 - 0,87 - 0,69 / - 3,40						
Positions	P, R, N, D Electronic shift available						
Control system	Mechatronik (Elektrohydraulic) Controlled on-load shifts Various shift programs available						
Weight (with oil)	< 310 Nm 72,0 kg / 350 Nm > 310 Nm 75,0 kg / 400 Nm > 310 Nm 76,5 kg / with torsion damper						

6HP19 A passenger-car automatic transmission

Technical data

Transmission type	Passenger-car automatic transmission with 6 forward speeds and 1 reverse 4 wheel drive layout in vehicle						
Transmission capacities	T max	Engine at 4000 1/min	= 350 Nm				= 400 Nm **
	P max		= 180 kW				= 220 kW
			bei 5500 1/min				bei 6000 1/min
	n max	in 1st - 5th gear	= 7200 1/min				= 6500 1/min
	n max	in 6th gear	= 5600 1/min				= 5600 1/min
	n max	KD- shift	= 6500 1/min				= 6000 1/min
	T max	Turbine forward	= 560 Nm				= 560 Nm *
	T max	Turbine reverse	= 300 Nm				= 300 Nm
	Slipping moment limit in the 1st gear Conditions has to be agreed						
Converter	< 230 Nm: W 235 R 2GWK < 310 Nm: W 245 R 2GWK > 310 Nm: W 255 RH 2GWK optional: W 255 RH 2GWK TD						
Gear Ratio	1.	2.	3.	4.	5.	6.	R
	4,17 - 2,34 - 1,52 - 1,14 - 0,87 - 0,69 / - 3,40						
Head gear (head set)	2,7 ... 4,5 Levels in 6% steps						
Moment distribution							
Front axle / rear axle	50 / 50						
Positions	P, R, N, D Electronic shift available						
Control system	Mechatronik (Elektrohydraulic) Controlled on-load shifts Various shift programs available						
Weight (with oil)	< 310 Nm 109,0 kg / 350 Nm > 310 Nm 112,0 kg / 400 Nm > 310 Nm 113,5 kg / with torsion damper						

6HP19 A passenger-car automatic transmission

Technical data

Transmission type	Passenger-car automatic transmission with 6 forward speeds and 1 reverse 4 wheel drive layout in vehicle						
Transmission capacities	T max	Engine at 4000 1/min	= 420 Nm				
	P max		= 236 kW				
				bei 6000 1/min			
	n max	in 1st - 5th gear	= 7000 1/min				
	n max	in 6th gear	= 5600 1/min				
	n max	KD- shift	= 6300 1/min				
	T max	Turbine forward	= 560 Nm *				
	T max	Turbine reverse	= 300 Nm				
	Slipping moment limit in the 1st gear						
Converter	bis 300 Nm: W 245 bis 400 Nm: W 255 With controlled-slip lock-up clutch Tp = 90 - 230 Nm at np = 2000 1/min						
Gear Ratio	1.	2.	3.	4.	5.	6.	R
	4,17	- 2,34	- 1,52	- 1,14	- 0,87	- 0,69	/ - 3,40
Head gear (head set)	2,7 ... 4,5 Levels in 6% steps						
Moment distribution							
Front axle / rear axle	50 / 50						
Positions	P, R, N, D Electronic shift available						
Control system	Mechatronik (Elektrohydraulic) Controlled on-load shifts Various shift programs available						
Weight (with oil)	114 kg (gilt für W 245 with out torsion damper)						

6HP26 passenger-car automatic transmission

Technical data

Transmission type: Passenger-car automatic transmission with 6 forward speeds and 1 reverse
Standard layout in vehicle

Transmission capacities:

T max	Engine at 4200 1/min	= 600 Nm
P max	Engine at 5800 1/min	= 320 kW
n max	in 1st - 5th gear 1/min	= 6200 1/min
n max	in 6th gear 1/min	= 5000 1/min
n max	KD shift 1/min	= 6000 1/min
T max	Turbine forward	= 800 Nm
T max	Turbine reverse	= 500 Nm

Converter: With controlled-slip lock-up clutch in gears 1- 6 and Reverse
Permissible continuous speed = 7000 1/min
Tp = 220- 412 at Mp = 2000 1/min

Gear:	1st	2nd	3rd	4th	5th	6th	Reverse
Ratio:	4.171	2.340	1.521	1.143	0.867	0.691	- 3.E2861403

Positions: Provision for mechanical shift with choice of 8 selector lever positions
P, R, N, D, 5, 4, 3, 2

Control system: Electrohydraulic (Mechatronik)
Controlled on-load shifts
Various shift programs available (ASIS)

Weight: app. 89 kg with oil

6HP26 A passenger-car automatic transmission

Technical data

Transmission type	Passenger-car automatic transmission with 6 forward speeds and 1 reverse 4 wheel drive layout in vehicle						
Transmission capacities	T max Engine at 4200 1/min	= 440 Nm	= 600 Nm				
	P max	= 230 kW bei 6600 1/min	= 320 kW bei 5800 1/min				
	n max in 1st - 5th gear	= 7200 1/min	= 6200 1/min				
	n max in 6th gear	= 5600 1/min	= 5000 1/min				
	n max KD- shift	= 7000 1/min	= 6000 1/min				
	T max Turbine forward	= 700 Nm	= 800 Nm				
	T max Turbine reverse	= 400 Nm	= 500 Nm				
Converter	W 260 S - 2 WK < Tmax Motor 440 Nm with controlled-slip lock-up clutch Tp = 120 - 300 Nm bei np = 2000 1/min W 280 S - 2 WK < Tmax Motor 440 Nm with controlled-slip lock-up clutch Tp = 210 - 410 Nm at np = 2000 1/min						
Gear Ratio	1.	2.	3.	4.	5.	6.	R
Head gear (head set)	4,17 - 2,34 - 1,52 - 1,14 - 0,87 - 0,69 / - 3,40						
Moment distribution Front axle / rear axle	2,7 ... 3,7						
Moment distribution Front axle / rear axle	50 / 50						
Positions	P, R, N, D Mechanical or electronic shifts						
Control system	Mechatronik (Elektrohydraulic) Controlled on-load shifts Various shift programs						
Weight (with oil)	129 kg / 440 Nm 136 kg / 600 Nm						

6HP26 A 61 passenger-car automatic transmission

Technical data

Transmission type	Passenger-car automatic transmission with 6 forward speeds and 1 reverse 4 wheel drive layout in vehicle						
Transmission capacities	T max Engine at 4200 1/min	= 440 Nm	= 600 Nm				
	P max	= 230 kW bei 6600 1/min	= 320 kW bei 5800 1/min				
	n max im 1st - 5th gear	= 7200 1/min	= 6200 1/min				
	n max in 6th gear	= 5600 1/min	= 5000 1/min				
	n max KD- shift	= 7000 1/min	= 6000 1/min				
	T max Turbine forward	= 700 Nm	= 800 Nm				
	T max Turbine reverse	= 400 Nm	= 500 Nm				
Converter	W 260 S - 2 WK < Tmax Motor 440 Nm with controlled-slip lock-up clutch Tp = 120 - 300 Nm at np = 2000 1/min W 280 S - 2 WK < Tmax Motor 440 Nm with controlled-slip lock-up clutch Tp = 210 - 410 Nm at np = 2000 1/min						
Gear Ratio	1.	2.	3.	4.	5.	6.	R
Head gear (head set)	4,17 - 2,34 - 1,52 - 1,14 - 0,87 - 0,69 / - 3,40						
Moment distribution Front axle / rear axle	2,7 ... 3,7						
Moment distribution Front axle / rear axle	50 / 50						
Positions	P, R, N, D Mechanical or electronic shifts						
Control system	Mechatronik (Elektrohydraulic) Controlled on-load shifts Various shift programs						
Weight (with oil)	136 kg / 440 Nm 143 kg / 600 Nm						

6HP32 passenger-car automatic transmission

Technical data

Transmission type	Passenger-car automatic transmission with 6 forward speeds and 1 reverse Standard layout in vehicle		
		Diesel	Benzin
Transmission capacities	T max Engine	= 750 Nm bei 2500 1/min	= 700 Nm bei 4000 1/min
	P max	= 320 kW bei 4500 1/min	= 320 kW bei 5700 1/min
	n max in 1st - 5th gear	= 5000 1/min	= 6000 1/min
	n max in 6th gear	= 4000 1/min	= 4700 1/min
	n max KD- shift	= 4800 1/min	= 5800 1/min
	T max Turbine foward	= 1000 Nm	= 1000 Nm
	T max Turbine reverse	= 600 Nm	= 600 Nm
Converter	W 300 S - 2 WK with controlled-slip lock-up clutch		
	Tp = 440 - 600 Nm at np = 2000 1/min		
Gear Ratio	1. 2. 3. 4. 5. 6. R		
	4,17 - 2,34 - 1,52 - 1,14 - 0,87 - 0,69 / - 3,40		
Positions	P, R, N, D Electronic shift		
Control system	Mechatronik (Elektrohydraulic) Controlled on-load shifts Various shift programs		
Weight (with oil)	99 kg / with out torsion damper 103 kg / with torsion damper		

6HP32 A passenger-car automatic transmission

Technical data

Transmission type Passenger-car automatic transmission with 6 forward speeds and 1 reverse
4 wheel drive layout in vehicle

		Diesel	Benzin
Transmission capacities	T max Engine	= 750 Nm at 2500 1/min	= 700 Nm at 4000 1/min
	P max	= 320 kW at 4500 1/min	= 340 kW at 5200 1/min
	n max in 1st - 5th gear	= 5000 1/min	= 6000 1/min
	n max in 6th gear	= 4000 1/min	= 4800 1/min
	n max KD- shift	= 4800 1/min	= 5800 1/min
	T max Turbine forward	= 1000 Nm	= 1000 Nm
	T max Turbine reverse	= 600 Nm	= 600 Nm

Converter W 300 S - 2 WK with controlled-slip lock-up clutch

$T_p = 440 - 600 \text{ Nm}$ at $n_p = 2000 \text{ 1/min}$

Gear	1.	2.	3.	4.	5.	6.	R
Ratio	4,17	- 2,34	- 1,52	- 1,14	- 0,87	- 0,69	/ - 3,40
Head gear (head set)	2,12 ... 2,57						

Moment distribution
Front axle / rear axle

50 / 50

Positions P, R, N, D
Mechanical or electronic shifts

Control system Mechatronik (Elektrohydraulic)
Controlled on-load shifts
Various shift programs

Weight (with oil) 159 kg