

REP-REP-RAE9012-1232501 REP-REP-RAE9012-1232501 - Replacing voltage regulator - V.3, VIN: XXXXXXXX

ISTA system version	4.30.30.23898	Data version	R4.30.30	Programming data	-
VIN	XXXXXXX	Vehicle	3'/E90/SEDAN/325i/N52,-/AUTO/ECE/LL/2007/05		
Int.lev.works	-	Int.lev.(cur.)	-	Int.lev.(tar.)	-
Mileage	-				

regulator

12 32 501**Replacing voltage***Necessary preliminary tasks:*

- Switch off ignition
- Disconnect [battery negative lead](#)
- [Notes](#) on removing and installing electronic control units
- Remove alternator

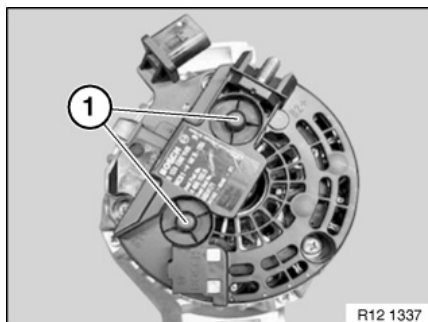
**Bosch:**

Release protective caps (1).

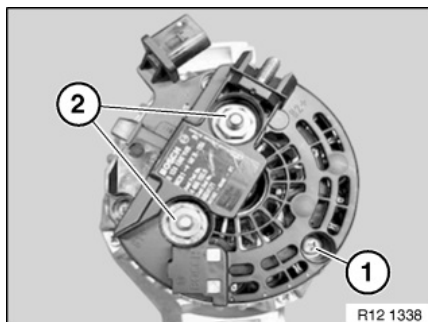
**Bosch:**

Release screw (1) and nuts (2), remove cover.

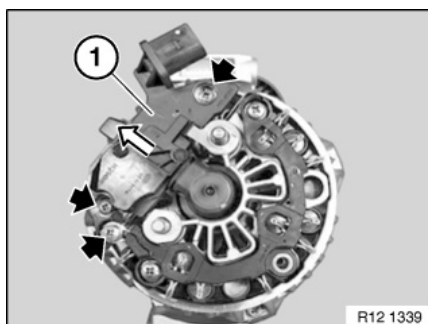
**Bosch:**

Release screws and remove regulator switch (1) in direction of arrow.

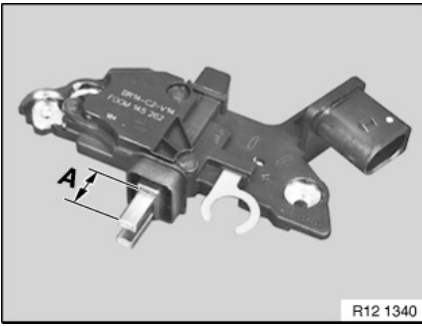
**Bosch:****Installation:**

Clean contact surfaces and check pretension of contact spring, replace regulator switch if necessary.

Measurement A = min. 5 mm.

Check collector ring for wear and recondition if necessary.

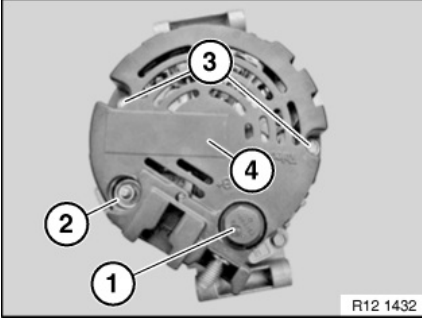
**Valeo:**

Slacken nut (1).

Slacken nut (2).

Release screws (3).

Release cover (4).

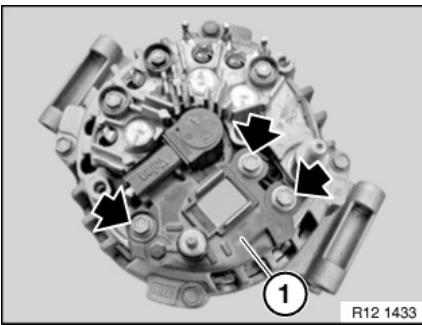
**Valeo:**

Release screws.

Remove regulator switch (1) towards top.

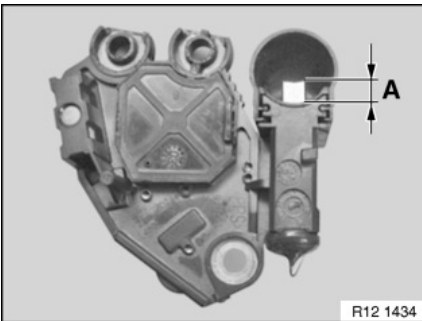
**Valeo:****Installation:**

Clean contact surfaces and check pretension of contact spring, replace regulator switch if necessary.

Measurement A = min. 5 mm.

Check collector ring for wear and recondition if necessary.

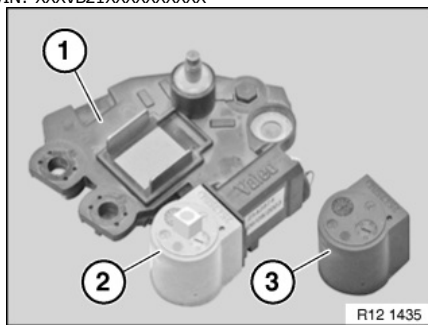
**Installation:**

Fit new regulator (1) with attached mounting sleeve (2) or locked carbon brush.

Pull off mounting sleeve (2) and replace with cover (3).