



This Service Information supersedes S.I. B00 02 06 **dated November 2006**.

**NEW** designates changes to this revision

## SUBJECT

### New Vehicle Preparation and Maintenance Requirements

## MODEL

2007 328i Sedan, 328i SULEV/PZEV, 328xi, 328xi SULEV/PZEV, 335i, 335xi (E90)

2007 328i Coupe, 328i SULEV/PZEV, 328xi, 328xi SULEV/PZEV, 335i (E92)

2007 328i, 328xi Sports Wagon (E91)

**NEW** 2007 328i, 328i SULEV/PZEV, 335i convertible (E93)

2007 525i, 525xi, 530i, 530xi, 550i Sedan (E60)

2007 M5 Sedan (E60)

2007 530xiT Sports Wagon (E61)

2007 650i, M6 Coupe (E63)

2007 650i, M6 Convertible (E64)

2007 Z4 3.0i Roadster, 3.0si Roadster, M Roadster (E85)

2007 Z4 3.0si Coupe, M Coupe (E86)

2007 750i (E65)

2007 750Li, 760Li (E66)

## SITUATION

Model	Production Start*	Comments
328i, 335i Coupe	8/06	Entirely new coupe, successor of E46. Engineering designation E92. New N52K (328i) and N54 (335i) engines.
328i, 335i Sedan	9/06	E90 sedan with new N52K (328i) and N54 (335i) engines.
328xi, 335xi Sedan; 328xi Coupe	9/06	All-wheel Drive version of E90 sedan and coupe using X-drive.
328i, 328xi Sedan; 328i,		New-generation N51 engine replaces M56 from

328xi Coupe SULEV/PZEV	9/06	E46 SULEV/PZEV models
328i, 328xi Sports Wagon	9/06	Sports Wagon version of 3 Series available with or without X-Drive. Engineering designation E91.
<b>NEW</b> 328i, 328i SULEV/PZEV, <b>NEW</b> 335i Convertible	2/07	Entirely new convertible, successor of E46 convertible. Engineering designation E93. Automatic Retractable Hard Top (RHT)
Z4 3.0i, 3.0si Roadster	9/06	No changes from 2006
Z4 M Roadster	9/06	No changes from 2006
Z4 3.0si Coupe	5/06	No changes from 2006
Z4 M Coupe	5/06	No changes from 2006
525i, 530i	3/06	No changes from 2006
525xi, 530xi	3/06	No changes from 2006
530xiT	3/06	No changes from 2006
550i	3/06	No changes from 2006
M5	9/06	No changes from 2006
M6 Coupe	9/06	No changes from 2006
M6 Convertible	9/06	Motorsport version of E64 6 Series convertible. Engine Oil Service at approx. 1200 miles.
650i Coupe, Convertible	9/06	No changes from 2006
750i, 750Li, 760Li	9/06	No changes from 2006

\* Availability approx. 1 month later.

### **Brief summary of new features on the 3 Series Coupe (E92):**

The 2007 3 Series models 328i and 335i coupes are completely redesigned compared to their 2006 E46 predecessors and carry the engineering designation E92.

- New body: Some basic dimensions of the previous 330Ci (E46) compared to the 2007 335i (E92) coupe. Values are for base versions with manual transmissions.

	<b>2007 335i (E92)</b>	<b>2006 330i (E46)</b>
overall length, in.	181.1	176.7
overall width (not including mirrors), in.	70.2	68.5
overall height, in.	54.1	53.9
wheelbase, in.	108.7	107.3
weight, lb.	3571	3285

front track, in.	59.1	57.9
rear track, in.	59.6	58.4
trunk volume, cu.ft.	15.2	14.5
fuel tank total capacity, gal.	16.1	16.6
engine oil capacity, qt.	6.9	6.9

### Brief summary of new features on the 3 Series Convertible (E93):

**NEW** The 3 Series convertible is based on the E92 coupe, and is the first BMW to feature a fully automatic retractable hard top (RHT). The RHT consists of 3 metal sections which separate when opening the top, then fold together and store completely inside the trunk. Even with the top down, there is room for luggage in the trunk. With the RHT in its closed position, the body-colored panels give the vehicle a coupe-like appearance.

- **NEW** New Engines for 3 Series sedans, coupes and convertibles:

Model	2007 335i	2006 330i	2007 328i	2006 325i
full designation	N54B30 O0	N52B30 OL	N52B30 M1	N52B30 UL
displacement (cc)	2979	2996	2996	2996
bore, stroke (mm)	84x89.6	85x88	85x88	85x88
maximum output, hp	300 @ 5800	255 @ 6600	230 @ 6500	215 @ 6250
maximum torque, lb. ft	300 @ 1400 - 5000	220 @ 2750	200 @ 2750	185 @ 2750
compression ratio, :1	10.2	10.7	12.1	10.7
injection	high-precision direct injection (HPI) with piezo injectors	manifold injection	manifold injection	manifold injection
intake	Air-to-air intake charge cooling. Twin turbochargers integrated into both exhaust manifolds.	naturally aspirated	naturally aspirated	naturally aspirated
valvetrain	double VANOS	double VANOS and Variable Valve Timing (VVT)	double VANOS and Variable Valve Timing (VVT)	double VANOS and Variable Valve Timing (VVT)

engine block	aluminum	alu-magnesium	alu-magnesium	alu-magnesium
spark plug thread	12mm	14mm	14mm	14mm
DME engine management	MSD80	MSV70	MSV80	MSV70

### Quality Certification 1 (QC1):

New QC1 forms been developed for the 2007 models covered in this Bulletin: SD92-316, **print date 07/06**. There are no operational changes compared to the previous 2007 QC1 form (print date 03/06). **NEW** Use this QC1 form for the E93 convertible, which does not require any additional operations.

Z4, all versions: Utilize QC1 Form SD92-316 of 7/06.

Z4 3.0i Roadster, 3.0si Roadster, M Roadster: Due to the setting/relaxing properties of the seals, the windows should be de-initialized and then initialized per TIS repair instruction RA 67 62 ...

**NEW** All 3 Series as of 3/07 vehicle production: Vehicles ordered with the optional iPod and USB Adapter will require an iPod interface cable, which must be presented to the customer. Refer to Aftersales Parts bulletin 65 04 07.

**NEW** All models with Condition Based Service (CBS): Vehicles being prepared on the GT1 for customer delivery (in contrast to those for demo service or showroom display), **must have the current date on which you perform the QC1 entered in "Date of First Registration"**. This is usually close enough to the actual date where the car will be registered.

**NEW** 3 Series convertible:

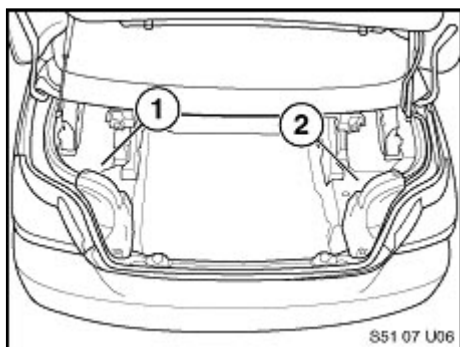

Inform your BMW center personnel as well as the customer, that if the car's top is to be lowered, there **must not be any object placed on either side section of the trunk** (1, 2; and arrows in the illustrations below), not even something as flat as the Vehicle Owner's Manual.

Placing an object in those locations will impede the opening of the top, because the RHT mechanism requires that space for storage when folded.

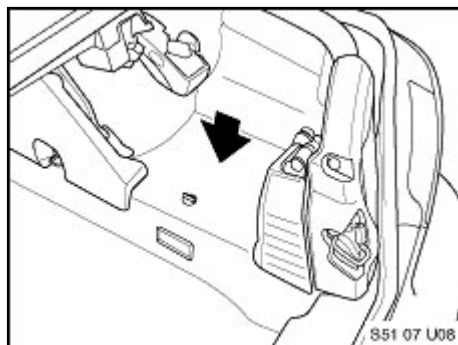
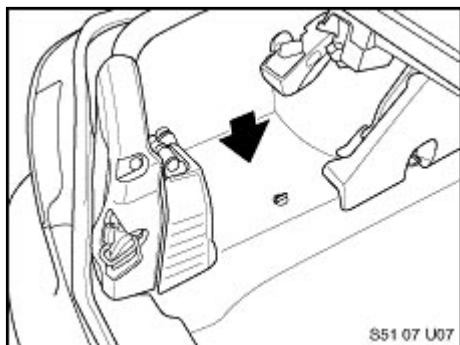

Avoid high-pressure "touchless" car washes with the 3 Series convertible, as you would with any convertible.

**Service Maintenance:**

**NEW** 3 Series: Minor changes compared to 2006 models. The N54 engines require their spark plugs to be replaced more frequently than N52KP engines due to the nature of the direct-injection process utilized on the N54 engine. Refer to the vehicle's Condition Based Service (CBS). Refer to SI B12 05 05 and [SI B00 07 02](#) for more information on CBS.

**NEW** 3 Series convertible: The spark plug replacement interval is no longer indicated in CBS. For the N52B30 M1 the interval is 100,000 miles; for the N54B30 O0 it is 45,000 miles.

M5, M6: at the 1200 mile Service, the engine air filter element must be replaced. This operation was mistakenly left off the 2007 Service/Warranty booklet dated 7/06.

All Referenced Models: Engine oil should be changed at least once per year. The BMW Maintenance Program allows for this operation if a vehicle does not travel enough to have a BMW Engine Oil Service performed. This detail is listed in the respective Service/Warranty booklet. Please make customers aware of this important fact when you review an upcoming Service Appointment. Refer to [SI B00 04 01](#).

**General Notes:**

2007 Service and Warranty Information booklet:

<b>NEW</b> 3 Series, all versions incl. convertible	SD92-322
Z4 Roadster 3.0, 3.0si	SD92-327
Z4 coupe 3.0si	SD92-327
M Roadster, M Coupe	SD92-329
525i, 525xi, 530i, 530xi, 530xiT, 550i	SD92-315
M5, M6, M6 Convertible	SD92-328
6 Series except M6	SD92-324
7 Series	SD92-325

Vehicle Data Status (Integration level):

3 Series Sedan	CIP V23.0	E89x-06-09-520
3 Series Coupe thru 8/06 production	CIP V22.2	E089-06-06-540
3 Series Coupe from 9/06	CIP V23.0	E89x-06-09-520
<b>NEW</b> 3 Series Convertible, thru 2/07 production	CIP V24.2	E89X-06-12-510
3 Series Convertible, as of 3/07 production	CIP V25.0	E89X-07-03-510
5 Series from 9/06	CIP V23.0	E060-06-09-520
6 Series	CIP V23.0	E060-06-09-520
7 Series	CIP V23.0	E065-06-09-520

**PARTS INFORMATION:**

Under separate cover, one pack of the Quality Certification I form for the 2007 BMWs will be sent to each BMW center's Service Manager. Additional copies of the forms for 2007 models may be ordered as listed below:

Item	Description	Qty	Price
SD92-316	Quality Certification I form (2007 3, 5, 6, 7 Series)	1 pack	\$4.75
	(print date 07/06)	(= 25 forms)	

These items are available online at BMW TIS under Materials Ordering. Refer to bulletin [B10 02 02](#) for instructions on how to place an order.

#### WARRANTY INFORMATION

2007 Model Year QCI payments will be automatically issued to BMW centers upon reporting a 2007 model year vehicle as retailed, or by placing the vehicle in service as a BMW center demonstrator or Service/Loaner vehicle. The payments, processed via a miscellaneous billing, will be based on the display and delivery check flat rates as published, utilizing each BMW center's warranty labor rate. The QCI line item on the repair order should be charged internally to the New Vehicle Sales Department.

#### Service

QCI	Display and Delivery Check*	Labor Allowance (FRU)
3 Series, all sedans, coupes and Sport Wagons	13**	
<b>NEW</b> 3 Series Convertible	13	
5 Series, all	12	
6 Series, all	12**	
7 Series, all	12	
Z4 roadster 3.0i, 3.0si, M roadster	12	
Z4 coupe 3.0si, M coupe	13	

\* value shown is the sum of Display and Delivery check per 8/06 KSD.

\*\* confirmed values for 3 Series sedan, M6 convertible.

#### BMW Company Vehicles

Reimbursement for performing the QCI on BMW company vehicles (of any model year) must still be requested by submitting a claim through DCS using the Spot Delivery codes as listed below:

<b>Defect Code:</b>	<b>11 99 99 77 BV</b>
Labor Operation:	00 00 012
Flat Rate Units:	Refer to KSD for flat rate times.

Note: BMW company vehicles delivered to field personnel may have already received a full QCI at the Vehicle Distribution Center (VDC) which serves your region. This should be evident upon arrival at your center by the absence of the usual protective seat and door panel covers and battery main-disconnect cable, correct wipers already installed, the Monroney label is not affixed to the window, etc. VDCs affix a small orange-colored label onto the center console near the transmission selector lever which reads "QC1 already done at VDC!". If this label is found, remove it prior to delivery to the employee. Please verify that the QC1 has already been performed at a VDC on a specific vehicle by contacting your regional Distribution Manager with the chassis#.

**IMPORTANT:**

As with all work that is reimbursed by BMWNA, the repair order, time recording and record keeping requirements outlined in the Warranty Policy and Procedures Manual must be strictly observed.

Quality Certification I payments are subject to audit.

**ATTACHMENTS**

view PDF attachment [SD92-316](#).

[ Copyright © 2007 BMW of North America, LLC ]